

Submersible pumps

The electric submersible sewage pumps have been specially designed to operate submerged in the pumped fluid. The hydraulic section is close coupled to the electric motor making the pumping unit compact, easy to install and reliable in operation. The pumps are essential in depuration systems and are widely used in the sewage handling facilities of industry and local communities. The GK series electric pumps are designed to pump sewage containing gas, compacted solids and long fibrous material. The pumps can be supplied for fixed or submersible installation with base frame. The design has paid particular attention to achieving a good overall efficiency to ensure that the pumps are as cheap as possible to run.

MOTOR

Asynchronous, three-phase with squirrel-cage rotor. The motor is cooled by the fluid in which it is submerged or by a forced cooling system. The motor is separated from the pump by a large chamber partially filled with oil that acts as a lubricant for the mechanical seals and as a heat exchanger. Ensure compliance with the minimum head value given with the dimensions of each individual electric pump in order to ensure that the motor is correctly cooled, the exception being made for motors with forced cooling.

SUPPORTS

The shaft of the motor, on the extension of which the impeller is mounted, is guided by two bearings prelubricated with grease; the lower one supports the axial thrust. The rotating assembly is very compact, with a short overhung pump shaft which reduces bearing loads and ensures reliability and long life.

MECHANICAL SEALS

The double mechanical seal (mounted in series) is a dual protection safeguarding the electric motor. If the seal on the pump side becomes faulty, the motor will not be damaged thanks to the second seal on the motor side. These seals are made of particularly suitable materials able to withstand heavy-duty conditions; the pump side seal is made with abrasionproof materials.

SAFE OPERATION

- The conductivity sensor in the oil chamber warns if there is water and transmits the relative signal to the appropriately preset electric panel. This checks that the mechanical seals on the pump side operate correctly.
- The motor is equipped with thermal probes connected in series in the stator winding. Should over-temperature conditions occur, the probes automatically cut off the power.

Electric pumps of the GK series feature three different hydraulics with the following characteristics.

Page 280

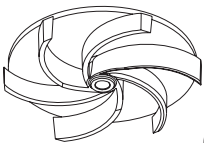

GKV

RETRACTED VORTEX IMPELLER

The impeller offers reliability against clogging due to the feature of wide through passages, and a good resistance to wear thanks to the absence of shimming. The versatility of use compensates for this impellers somewhat lower efficiency. The impeller can be reduced in dimension to offer different characteristics. For water containing a large amount of solids and long fibre, sewage with a high gas and sludge content.

Page 293

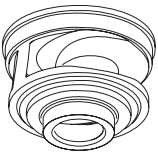

GKC

SINGLE-CHANNEL IMPELLER

It offers reliability against clogging and features wide through sections and a good resistance to wear, low mechanical action on the fluid, high hydraulic efficiency. Particularly suitable for clean water, water containing solid and fibrous solids, cloacal water, sewage and sludge. Low vibrations thanks to the dynamically balanced impeller.

Page 316

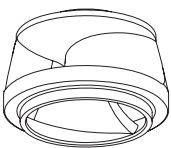

GKN

DOUBLE CHANNEL IMPELLER

It offers reliability against clogging and features wide through sections and a good resistance to wear, low mechanical action on the fluid, high hydraulic efficiency. Particularly suitable for clean water, water containing solid and fibrous solids, cloacal water, sewage and sludge. Low vibrations thanks to the dynamically balanced impeller.

Page 327

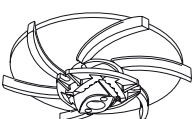

GKG

SHREDDER

Made of very hard stainless steel, the shape of the shredder ensures long-life and fade-free shredding capacity. Waste water disposal from gas stations, community housing and neighbourhoods. No particular tools are required to replace this part.

STANDARD INSTALLATIONS

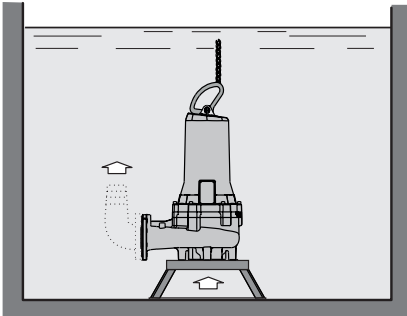

Mobile and emergency immersed installation with support foot

Version only recommended with electric pump installed on a solid and flat support surface and with flexible delivery pipe, particularly suitable for:

- all occasional or exceptional uses
- use on site or where mobility is required
- renovation of existing stations with architectural constraints.

The support frame, flexible delivery pipe bend, chain, etc. are available.

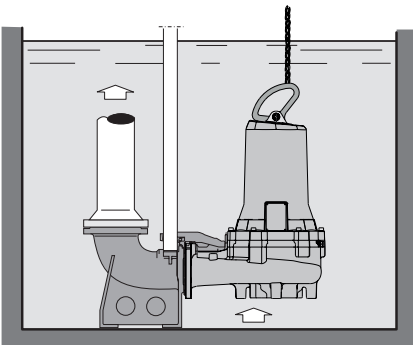

Fixed installation with guide chute and automatic coupling base.

It is the most suitable installation for fixed lifting stations. No special building infrastructures are required and the system is easy to build. The quick coupling allows quick and easy extraction and subsequent repositioning

of the electric pump in the tank, allowing ordinary maintenance or exceptional interventions to be performed in complete safety without having to enter the collection tank. The coupling foot, guide pipes, chain, etc. are available for this installation.

IN A DRY CHAMBER

It is the horizontal or vertical installation that requires a dry chamber, adjacent to the liquid collection tank, to house the electric pump unit.

Compared to traditional non-submersible machines, it has maximum operating safety and absence of risks even in the event that the dry chamber is submerged in liquid. Support stands are available.

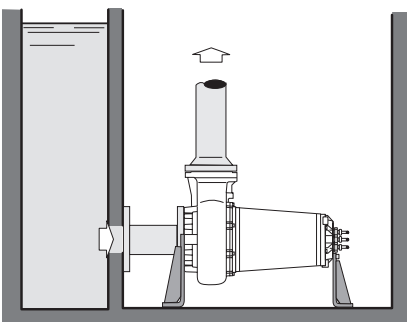

HORIZONTAL

With outlet vent pointing upwards. The electric pump is attached with support brackets.

This arrangement requires a limited number of special pieces. The suction is horizontal and the delivery is vertical with a limited overall height.

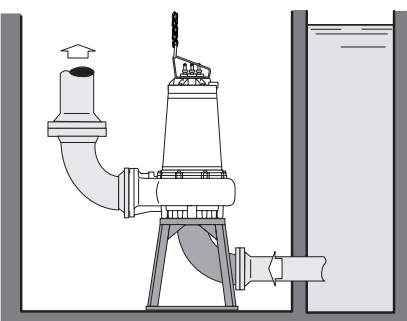

VERTICAL

This arrangement allows for maximum ease of inspection and maintenance, the suction and delivery are horizontal and it ensures minimum overall dimensions in plan configuration.

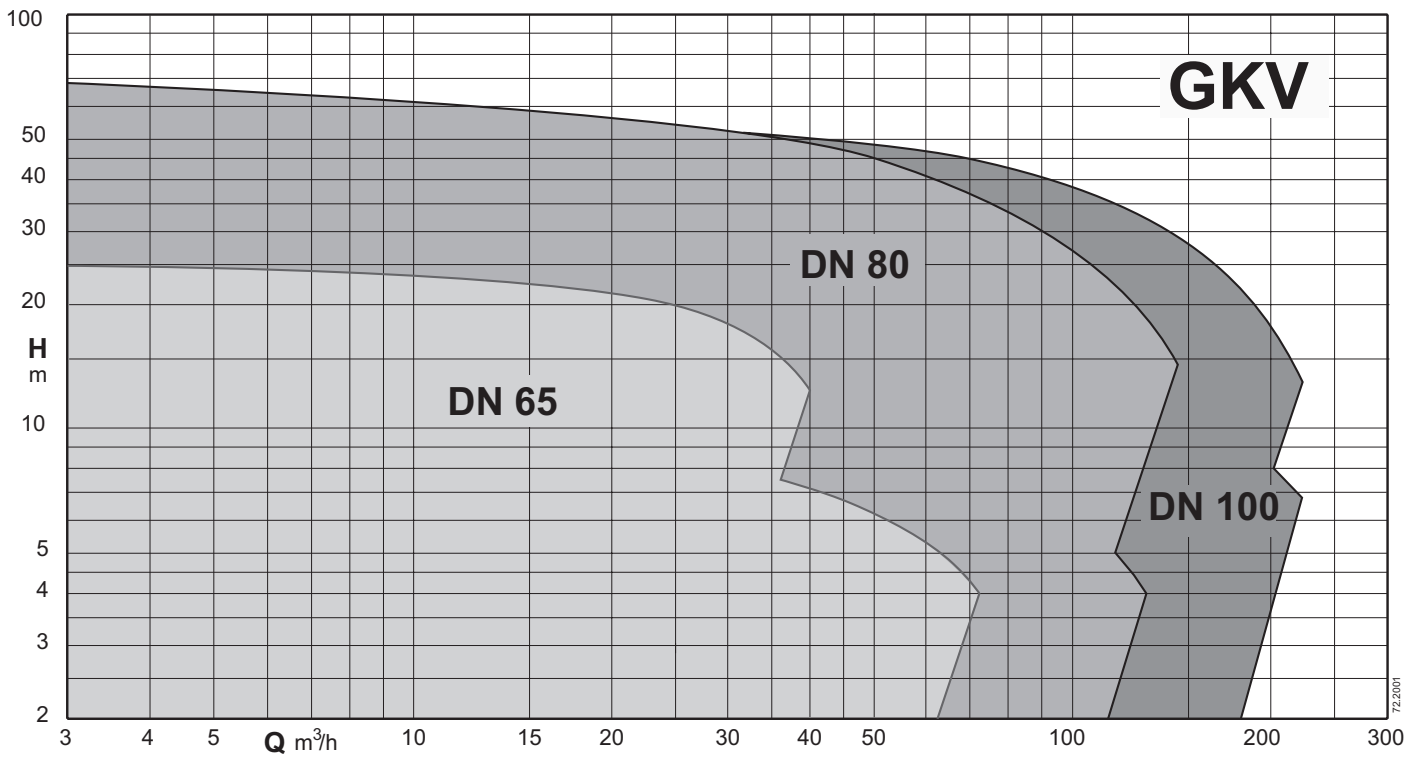

Submersible pumps with vortex impeller

Construction

Submersible pumps with vortex impeller. The impeller offers reliability against clogging due to the feature of wide through passages, and a good resistance to wear thanks to the absence of shimming. The versatility of use compensates for this impellers somewhat lower efficiency. The impeller can be reduced in dimension to offer different characteristics. Delivery port DN 65-80-100.

Applications

For waste water and sewage with suspended bodies and with the presence of filamentous bodies, they are particularly suitable for the emptying of wells or primary collection tanks and septic tanks in domestic, residential and industrial installations. Solid passage from 40 to 100mm

Operating conditions

Liquid temperature: from 0°C to +40°C.
 Maximum immersion depth: 20m (with cable of suitable length).
 Maximum working pressure: 80 m.w.c.
 pH of the liquid to be lifted: 4 ÷ 10
 Continuous service (with water at minimum immersion level).

Materials

Pump casing: cast iron EN-GJL250 UNI-EN 1561-11
 Impeller: cast iron EN-GJL250 UNI-EN 1561-11
 Motor casing: cast iron EN-GJL250 UNI-EN 1561-11
 Shaft: stainless steel X20Cr13 (AISI420)
 Motor side mechanical seal: graphite/ceramic
 Pump side mechanical seal: silicon carbide/ceramic

Technical data

TYPE	Dry chamber version		Probes		Cable		Class Isolation /Efficiency	Duck foot coupling	Submersible pump rest	Dry chamber pump rest	Dry chamber pump support
	Vertical	Horizontal	thermal	conductivity	NSSHOU-J	H07RN-F					
GKV4 65-55G-0016F	-	-	o	o	-	•	H / IE3	SAK 65-65-2	-	-	-
GKV4 65-55D-0021F	-	-	o	o	-	•	H / IE3	SAK 65-65-2	-	-	-
GKV4 65-55A-0026F	-	-	o	o	-	•	H / IE3	SAK 65-65-2	-	-	-
GKV2 65-40L-0020F	-	-	o	o	-	•	H / IE3	SAK 65-65-2	-	-	-
GKV2 65-40G-0025F	-	-	o	o	-	•	H / IE3	SAK 65-65-2	-	-	-
GKV2 65-40A-0031F	-	-	o	o	-	•	H / IE3	SAK 65-65-2	-	-	-
GKV2 65-40D-0031F	-	-	o	o	-	•	H / IE3	SAK 65-65-2	-	-	-
GKV6 80-80P-0015H	#	#	•	•	•	-	H / IE3	SAK 80-80-2	APK 80	APCK 80	SOK80/N3
GKV6 80-80M-0015H	#	#	•	•	•	-	H / IE3	SAK 80-80-2	APK 80	APCK 80	SOK80/N3
GKV6 80-80I-0015H	#	#	•	•	•	-	H / IE3	SAK 80-80-2	APK 80	APCK 80	SOK80/N3
GKV6 80-80E-0015H	#	#	•	•	•	-	H / IE3	SAK 80-80-2	APK 80	APCK 80	SOK80/N3
GKV6 80-80A-0015H	#	#	•	•	•	-	H / IE3	SAK 80-80-2	APK 80	APCK 80	SOK80/N3
GKV4 80-80P-0016H	#	#	•	•	•	-	H / IE3	SAK 80-80-2	APK 80	APCK 80	SOK80/N3
GKV4 80-80M-0016H	#	#	•	•	•	-	H / IE3	SAK 80-80-2	APK 80	APCK 80	SOK80/N3
GKV4 80-80I-0021H	#	#	•	•	•	-	H / IE3	SAK 80-80-2	APK 80	APCK 80	SOK80/N3
GKV4 80-80H-0029H	#	#	•	•	•	-	H / IE3	SAK 80-80-2	APK 80	APCK 80	SOK80/N3
GKV4 80-80E-0037H	#	#	•	•	•	-	H / IE3	SAK 80-80-2	APK 80	APCK 80	SOK80/N3
GKV4 80-80P-0046H	#	#	•	•	•	-	H / IE3	SAK 80-80-2	APK 80	APCK 80	SOK80/N3
GKV4 80-80A-0058H	#	#	•	•	•	-	H / IE3	SAK 80-80-2	APK 80	APCK 80	SOK80/N3
GKV2 80-80V-0048H	#	#	•	•	•	-	H / IE3	SAK 80-80-2	APK 80	APCK 80	SOK80/N3
GKV2 80-80X-0048H	#	#	•	•	•	-	H / IE3	SAK 80-80-2	APK 80	APCK 80	SOK80/N3
GKV2 80-80Z-0048H	#	#	•	•	•	-	H / IE3	SAK 80-80-2	APK 80	APCK 80	SOK80/N3
GKV2 80-80N-0065H	#	#	•	•	•	-	H / IE3	SAK 80-80-2	APK 80	APCK 80	SOK80/N3
GKV2 80-80P-0065H	#	#	•	•	•	-	H / IE3	SAK 80-80-2	APK 80	APCK 80	SOK80/N3
GKV2 80-80Q-0065H	#	#	•	•	•	-	H / IE3	SAK 80-80-2	APK 80	APCK 80	SOK80/N3
GKV2 80-80R-0065H	#	#	•	•	•	-	H / IE3	SAK 80-80-2	APK 80	APCK 80	SOK80/N3
GKV2 80-80T-0065H	#	#	•	•	•	-	H / IE3	SAK 80-80-2	APK 80	APCK 80	SOK80/N3
GKV2 80-80W-0048H	#	#	•	•	•	-	H / IE3	SAK 80-80-2	APK 80	APCK 80	SOK80/N3
GKV2 80-80W-0065H	#	#	•	•	•	-	H / IE3	SAK 80-80-2	APK 80	APCK 80	SOK80/N3

• = Standard o = Optional # = Version with oil chamber
 - = Not present

Motor

Induction motor with 2, 4 or 6 poles, 50Hz.
Three-phase version: 400V ± 10% up to 4.8 kW
 400/690V ± 10% from 5.8 kW
 Isolation class: H
 Degree of protection: IP 68
 Max number of starts per hour:
 - 20 up to 5 kW
 - 15 up to 10 kW
 - 10 for higher powers
 Cable: length 10m
 Direction of rotation: clockwise top view
 Motor suitable for operation with frequency converter.

Designation

GKV4 65-55D-0021F
 GK = Series
 V = Vortex impeller
 4 = Number of poles
 65 = Delivery port diameter in mm
 55 = Free passage in mm
 D = Impeller trim
 0021 = Motor size kW x 10
 F · = · Electric motor flange size

= In case of operation in a dry chamber or with a low level of the pumped liquid, it is necessary to introduce the cooling oil according to the quantities indicated in the use and maintenance manual

Technical data

TYPE	Dry chamber version		Probes		Cable		Class	Duck foot coupling	Submersible pump rest	Dry chamber pump rest	Dry chamber pump support
	Vertical	Horizontal	thermal	conductivity	NSSHOU-J	H07RN-F	Isolation				
GKV2 80-80W-0090H	#	#	•	•	•	-	H	SAK 80-80-2	APK 80	APCK 80	SOK80/N3
GKV2 80-80T-0090H	#	#	•	•	•	-	H	SAK 80-80-2	APK 80	APCK 80	SOK80/N3
GKV2 80-80R-0090H	#	#	•	•	•	-	H	SAK 80-80-2	APK 80	APCK 80	SOK80/N3
GKV2 80-80Q-0090H	#	#	•	•	•	-	H	SAK 80-80-2	APK 80	APCK 80	SOK80/N3
GKV2 80-80P-0090H	#	#	•	•	•	-	H	SAK 80-80-2	APK 80	APCK 80	SOK80/N3
GKV2 80-80N-0090H	#	#	•	•	•	-	H	SAK 80-80-2	APK 80	APCK 80	SOK80/N3
GKV2 80-80R-0125L	#	#	•	•	•	-	H	SAK 80-80-2	APK 80	APCK 80	SOK80/N3
GKV2 80-80P-0165L	#	#	•	•	•	-	H	SAK 80-80-2	APK 80	APCK 80	SOK80/N3
GKV2 80-80L-0165L	#	#	•	•	•	-	H	SAK 80-80-2	APK 80	APCK 80	SOK80/N3
GKV2 80-80G-0165L	#	#	•	•	•	-	H	SAK 80-80-2	APK 80	APCK 80	SOK80/N3
GKV2 80-80D-0165L	#	#	•	•	•	-	H	SAK 80-80-2	APK 80	APCK 80	SOK80/N3
GKV2 80-80A-0165L	#	#	•	•	•	-	H	SAK 80-80-2	APK 80	APCK 80	SOK80/N3
GKV6 100-100E-0040L	#	#	•	•	•	-	H	SAK 100-100-2A	APK 100	APCK 100	SOK100/N3
GKV6 100-100C-0040L	#	#	•	•	•	-	H	SAK 100-100-2A	APK 100	APCK 100	SOK100/N3
GKV6 100-100A-0040L	#	#	•	•	•	-	H	SAK 100-100-2A	APK 100	APCK 100	SOK100/N3
GKV4 100-100R-0021H	#	#	•	•	•	-	H	SAK 100-100-2A	APK 100	APCK 100	SOK100/N3
GKV4 100-100N-0029H	#	#	•	•	•	-	H	SAK 100-100-2A	APK 100	APCK 100	SOK100/N3
GKV4 100-100L-0037H	#	#	•	•	•	-	H	SAK 100-100-2A	APK 100	APCK 100	SOK100/N3
GKV4 100-100F-0046H	#	#	•	•	•	-	H	SAK 100-100-2A	APK 100	APCK 100	SOK100/N3
GKV4 100-100A-0058H	#	#	•	•	•	-	H	SAK 100-100-2A	APK 100	APCK 100	SOK100/N3
GKV4 100-100E-0075L	#	#	•	•	•	-	H	SAK 100-100-2A	APK 100	APCK 100	SOK100/N3
GKV4 100-100C-0105L	#	#	•	•	•	-	H	SAK 100-100-2A	APK 100	APCK 100	SOK100/N3
GKV4 100-100A-0125L	#	#	•	•	•	-	H	SAK 100-100-2A	APK 100	APCK 100	SOK100/N3
GKV2 100-80L-0260N	#	-	•	•	•	-	H	SAK 100-100-2A	APK 100A	APCK 100	-
GKV2 100-80I-0260N	#	-	•	•	•	-	H	SAK 100-100-2A	APK 100A	APCK 100	-
GKV2 100-80H-0350N	#	-	•	•	•	-	H	SAK 100-100-2A	APK 100A	APCK 100	-
GKV2 100-80G-0350N	#	-	•	•	•	-	H	SAK 100-100-2A	APK 100A	APCK 100	-
GKV2 100-80F-0350N	#	-	•	•	•	-	H	SAK 100-100-2A	APK 100A	APCK 100	-
GKV2 100-80E-0350N	#	-	•	•	•	-	H	SAK 100-100-2A	APK 100A	APCK 100	-
GKV2 100-80D-0350N	#	-	•	•	•	-	H	SAK 100-100-2A	APK 100A	APCK 100	-

• = Standard
- = Not present

o = Optional

= Version with oil chamber

= In case of operation in a dry chamber or with a low level of the pumped liquid, it is necessary to introduce the cooling oil according to the quantities indicated in the use and maintenance manual

Performance

n ≈ 1450 1/min

				Q = Flow													
				m³/h	0	2,9	3,6	7,2	10,8	14,4	18	21,5	25,2	28,8	32,4	36	54
Model	400V	P2	l/min	0	48,33	60	120	180	240	300	358	420	480	540	600	900	1200
	A	kW	H (m) = Total head														
GKV4 65-55G-0016F	3,7	1,6		7,8	7,8	7,7	7,7	7,5	7,3	7,1	6,9	6,6	6,3	5,9	5,5	5,1	-
GKV4 65-55D-0021F	5,1	2,1		9,3	9,3	9,1	9,1	8,9	8,6	8,4	8,1	7,9	7,6	7,4	7,1	6,8	-
GKV4 65-55A-0026F	5,8	2,6		10,6	10,5	10,4	10,2	10	9,9	9,7	9,4	9,2	8,9	8,7	8,4	6,5	4,1

n ≈ 2850 1/min

				Q = Flow															
				m³/h	0	2,2	2,5	2,9	3,2	3,6	7,2	10,8	14,4	18	21,5	25,2	28,8	32,4	36
Model	400V	P2	l/min	0	36,66	41,66	48,33	53,33	60	120	180	240	300	358	420	480	540	600	660
	A	kW	H (m) = Total head																
GKV2 65-40L-0020F	4,1	2		15,8	15	14,9	14,7	14,6	14,5	13,3	12,4	11,6	10,8	10,1	9,3	8,6	7,8	7	6,2
GKV2 65-40G-0025F	5,5	2,5		17,4	16,9	16,8	16,7	16,6	16,6	15,7	14,9	14,2	13,5	12,8	12,1	11,3	10,4	9,5	8,5
GKV2 65-40A-0031F	5,6	3,1		26,8	-	-	-	-	-	24,5	23,4	22,3	21,2	20,1	18,9	-	-	-	-
GKV2 65-40D-0031F	5,6	3,1		22,7	22	21,9	21,8	21,7	21,6	20,6	19,6	18,6	17,7	16,8	15,9	14,8	13,8	12,7	11,6

n ≈ 950 1/min

				Q = Flow														
				m³/h	0	2,2	2,9	3,6	7,2	10,8	14,4	18	21,5	25,2	28,8	32,4	36	54
Model	400V	P2	l/min	0	36,66	48,33	60	120	180	240	300	358	420	480	540	600	900	1200
	A	kW	H (m) = Total head															
GKV6 80-80P-0015H	3,4	1,5		3,1	3,1	3,1	3	2,9	2,7	2,5	2,2	2	1,7	1,4	1	0,6	-	-
GKV6 80-80M-0015H	3,4	1,5		4,1	4	4	4	3,8	3,6	3,4	3,2	2,9	2,7	2,4	2,1	1,8	-	-
GKV6 80-80I-0015H	3,4	1,5		4,7	4,6	4,6	4,6	4,4	4,3	4,1	3,9	3,7	3,4	3,2	2,9	2,7	1,4	-
GKV6 80-80E-0015H	3,4	1,5		6,1	6	6	6	5,8	5,6	5,4	5,2	5	4,8	4,6	4,4	4,2	2,9	1,4
GKV6 80-80A-0015H	3,4	1,5		7,6	7,5	7,4	7,4	7,2	7	6,7	6,5	6,3	6,1	5,9	5,7	5,4	4,2	2,7

n ≈ 1450 1/min

					Q = Flow													
					m³/h	0	2,9	3,6	7,2	14,4	21,5	28,8	36	54	72	90	108	126
Model	400V	400V	690V	P2	l/min	0	48,33	60	120	240	358	480	600	900	1200	1500	1800	2100
	A	A	A	kW	H (m) = Total head													
GKV4 80-80P-0016H	3,4	-	-	1,6		6,9	6,8	6,8	6,6	6,1	5,4	4,6	3,7	-	-	-	-	-
GKV4 80-80M-0016H	3,4	-	-	1,6		9,4	9,2	9,1	8,9	8,3	7,8	7,2	6,4	4,3	-	-	-	-
GKV4 80-80I-0021H	5,0	-	-	2,1		10,9	10,8	10,7	10,5	10	9,5	8,8	8,1	6,2	4,1	-	-	-
GKV4 80-80H-0029H	6,1	-	-	2,9		12,4	12,2	12,2	11,9	11,4	10,9	10,2	9,6	7,7	5,6	3,3	-	-
GKV4 80-80E-0037H	7,7	-	-	3,7		14,1	13,9	13,8	13,5	12,9	12,3	11,7	11,1	9,6	7,7	5,6	3	-
GKV4 80-80C-0046H	9,5	-	-	4,6		15,7	15,5	15,5	15,2	14,6	14	13,4	12,7	11,1	9,4	7,6	5,7	-
GKV4 80-80A-0058H	-	11,9	6,9	5,8		17,3	17	16,9	16,6	15,8	15	14,3	13,6	12,1	10,5	8,7	6,5	4,2

n ≈ 2850 1/min

					Q = Flow																
					m³/h	0	1,4	2,2	2,9	3,6	7,2	10,8	14,4	18	21,5	25,2	28,8	32,4	36	54	72
Model	400V	400V	690V	P2	l/min	0	23,33	36,66	48,33	60	120	180	240	300	358	420	480	540	600	900	1200
	A	A	A	kW	H (m) = Total head																
GKV2 80-80V-0048H	8,9	-	-	4,8		19,5	19,5	19,4	19,4	19,4	19,1	18,8	18,3	17,9	17,3	16,8	16,2	15,6	15	-	-
GKV2 80-80X-0048H	8,9	-	-	4,8		17	17	16,9	16,9	16,9	16,6	16,2	15,8	15,4	15	14,5	14,1	13,6	13,1	10,5	-
GKV2 80-80Z-0048H	8,9	-	-	4,8		14	14	13,9	13,9	13,9	13,6	13,3	12,9	12,5	12	11,5	11	10,5	9,9	6,6	-
GKV2 80-80W-0048H	8,9	-	-	4,8		25,1	25	24,9	24,8	24,8	24,4	24	23,5	23,1	22,5	22	21,3	20,6	-	-	-
GKV2 80-80N-0065H	-	11,9	6,9	6,5		34,9	34,8	34,8	34,8	34,8	34,6	34,2	33,5	32,6	31,7	-	-	-	-	-	-
GKV2 80-80P-0065H	-	11,9	6,9	6,5		28,8	28,6	28,5	28,4	28,3	27,9	27,5	27,1	26,6	26,2	25,7	25,1	24,5	23,9	-	-
GKV2 80-80Q-0065H	-	11,9	6,9	6,5		33,1	33,1	33,1	33,1	33	32,7	32,2	31,7	31,1	30,5	29,9	29,4	-	-	-	-
GKV2 80-80R-0065H	-	11,9	6,9	6,5		30,9	30,8	30,7	30,7	30,6	30,3	30	29,5	28,9	28,3	27,6	27	26,3	25,5	-	-
GKV2 80-80T-0065H	-	11,9	6,9	6,5		26,7	26,6	26,6	26,6	26,5	26,2	25,9	25,4	24,9	24,3	23,7	23,1	22,4	21,7	18,2	-
GKV2 80-80W-0065H	-	11,9	6,9	6,5		25,6	25,5	25,5	25,5	25,4	25,1	24,7	24,2	23,6	23	22,4	21,7	21,1	20,4	16,6	12,3

Performance

n ≈ 2850 1/min

Model	400V	690V	P2	Q = Flow																
				m³/h	0															
				l/min	1,4	2,2	2,9	3,2	3,6	7,2	14,4	21,5	28,8	36	54	72	90	108	126	144
A			kW	H (m) = Total head																
GKV2 80-80W-0090H	16,3	9,4	9	25,5	-	-	-	25,2	25,2	24,9	24	22,9	21,6	20,3	16,9	13,5	10,4	7,6	4,9	-
GKV2 80-80T-0090H	16,3	9,4	9	26,6	-	-	-	26,3	26,3	25,9	25,1	24	22,9	21,6	18	14,5	11,2	8,3	-	-
GKV2 80-80R-0090H	16,3	9,4	9	30,7	-	-	-	30,4	30,4	30,1	29,2	28	26,8	25,4	21,6	17,7	13,9	10,3	-	-
GKV2 80-80Q-0090H	16,3	9,4	9	33	-	-	-	32,7	32,7	32,3	31,4	30,2	28,8	27,2	23,1	19	15	-	-	-
GKV2 80-80P-0090H	16,3	9,4	9	28,7	-	-	-	28,4	28,4	28,1	27,2	26,2	25	23,6	19,9	16	12,5	9,4	-	-
GKV2 80-80N-0090H	16,3	9,4	9	34,9	-	-	-	34,8	34,7	34,5	33,5	32	30,4	28,9	25,6	-	-	-	-	-
GKV2 80-80R-0125L	22,4	12,9	12,5	33,3	33,2	33,1	33,1	-	33	32,7	31,9	31	29,9	28,7	25,3	21,5	17,8	14,3	11,2	8,4
GKV2 80-80P-0165L	31	17,9	16,5	41,8	41,7	41,7	41,6	-	41,6	41,5	40,7	39,6	38,3	36,9	33,2	29,3	25,5	21,8	18,1	14,1
GKV2 80-80L-0165L	31	17,9	16,5	47,7	47,6	47,6	47,6	-	47,5	47,3	46,5	45,5	44,3	43	39,7	36,5	33,1	-	-	-
GKV2 80-80G-0165L	31	17,9	16,5	55,2	55,2	55,1	55,1	-	55,1	54,9	54,2	53,1	51,7	50,3	46,6	-	-	-	-	-
GKV2 80-80D-0165L	31	17,9	16,5	61,5	61,4	61,4	61,3	-	61,2	60,8	59,8	58,2	56,1	53,7	-	-	-	-	-	-
GKV2 80-80A-0165L	31	17,9	16,5	67,7	67,6	67,5	67,4	-	67,3	66,7	65,2	-	-	-	-	-	-	-	-	-

n ≈ 950 1/min

Model	400V	P2	Q = Flow											
			m³/h	0										
			l/min	7,2	14,4	21,5	28,8	36	54	72	90	108	126	144
A		kW	H (m) = Total head											
GKV6 100-100E-0040L	9	4	7,3	7,1	6,9	6,6	6,3	6	5,2	4,2	3,1	1,7	-	-
GKV6 100-100C-0040L	9	4	8,3	8,1	7,9	7,7	7,4	7,2	6,4	5,5	4,5	3,3	2,1	0,7
GKV6 100-100A-0040L	9	4	10,1	9,8	9,5	9,2	8,9	8,6	7,9	7,2	6,4	5,4	4,3	2,9

n ≈ 1450 1/min

Model	400V	400V	690V	P2	Q = Flow															
					m³/h	0														
					l/min	0	7,2	14,4	21,5	28,8	36	45	54	63	72	81	90	99	108	117
A				kW	H (m) = Total head															
GKV4 100-100R-0021H	5,0	-	-	2,1	7,4	7,2	7	6,8	6,5	6,1	5,7	5,1	4,5	3,8	3,1	2,4	-	-	-	-
GKV4 100-100N-0029H	6,1	-	-	2,9	8,8	8,6	8,3	8,1	7,8	7,5	7,1	6,6	6	5,3	4,6	3,8	2,9	2	-	-
GKV4 100-100L-0037H	7,7	-	-	3,7	10	9,7	9,4	9,2	8,9	8,5	8,1	7,5	6,9	6,3	5,7	5	4,4	3,8	3,1	2,3
GKV4 100-100F-0046H	9,5	-	-	4,6	11,6	11,5	11,3	11,1	10,7	10,4	9,9	9,3	8,8	8,3	7,7	7,1	6,5	5,9	5,2	-
GKV4 100-100A-0058H	-	11,9	6,9	5,8	15	14,5	14,1	13,8	13,4	13,1	12,6	12,2	11,8	11,3	10,8	10,3	9,7	9,1	-	-

n ≈ 1450 1/min

Model	400V	690V	P2	Q = Flow													
				m³/h	0												
				l/min	10,8	18	36	54	72	90	108	126	144	162	180	216	
A			kW	H (m) = Total head													
GKV4 100-100E-0075L	15,3	8,8	7,5	16,6	16,4	16,2	15,2	14	12,7	11,2	9,7	8,2	6,7	5,2	-	-	
GKV4 100-100C-0105L	20	11,5	10,5	18,8	18,5	18,2	17,2	16,1	14,9	13,6	12,2	10,8	9,4	7,8	6,1	-	
GKV4 100-100A-0125L	24	13,9	12,5	23	22,4	22,1	21,1	20	18,9	17,7	16,5	15,3	13,9	12,6	11,1	7,9	

n ≈ 2850 1/min

Model	400V	690V	P2	Q = Flow																
				m³/h	0															
				l/min	7,2	14,4	21,5	28,8	36	54	72	90	108	126	144	162	180	198	216	
A			kW	H (m) = Total head																
GKV2 100-80L-0260N	44,6	25,7	26	29,2	28,8	28,3	27,8	27,3	26,7	25,2	23,5	21,7	19,7	17,6	15,3	12,9	10,4	7,9	-	
GKV2 100-80I-0260N	44,6	25,7	26	35,4	35	34,7	34,2	33,8	33,3	31,8	30,2	28,3	26,2	23,9	21,5	19	16,3	-	-	
GKV2 100-80H-0350N	57,8	33,4	35	40,6	40,1	39,6	39,1	38,6	38,1	36,8	35,4	33,8	32,1	30,1	27,8	25,4	22,7	19,8	16,8	
GKV2 100-80G-0350N	57,8	33,4	35	45,5	45,1	44,6	44,2	43,7	43,2	41,9	40,3	38,5	36,5	34,3	32	29,4	26,7	-	-	
GKV2 100-80F-0350N	57,8	33,4	35	49,7	49,3	48,9	48,5	48,1	47,6	46,1	44,3	42,2	40	37,6	34,9	-	-	-	-	
GKV2 100-80E-0350N	57,8	33,4	35	53,4	53,1	52,7	52,3	51,9	51,4	50	48,3	46,2	43,9	41,5	-	-	-	-	-	
GKV2 100-80D-0350N	57,8	33,4	35	56,3	56	55,7	55,3	54,9	54,4	52,9	51,1	49	46,6	-	-	-	-	-	-	

Characteristic curves

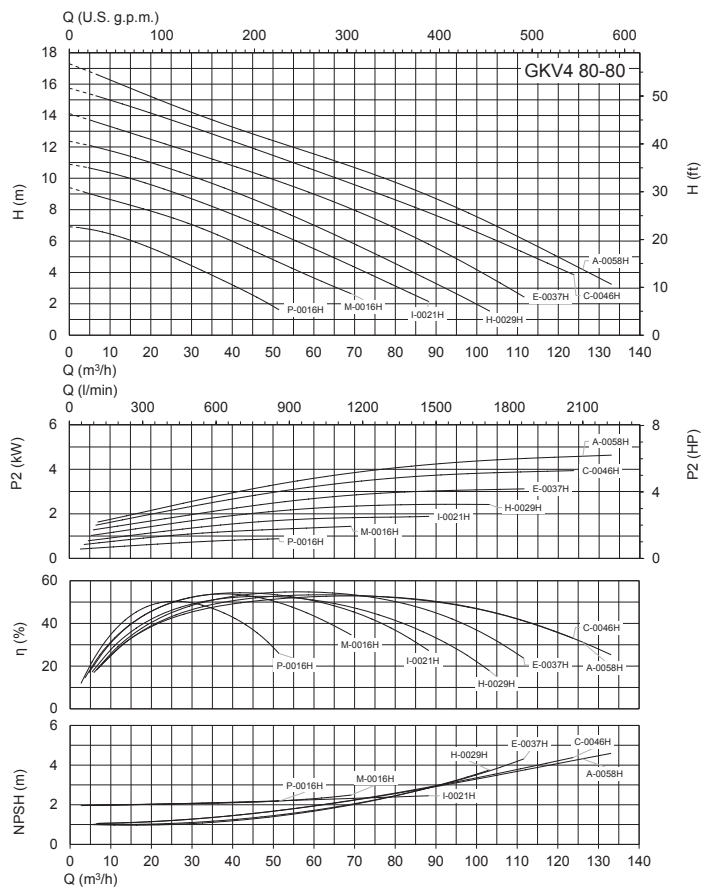
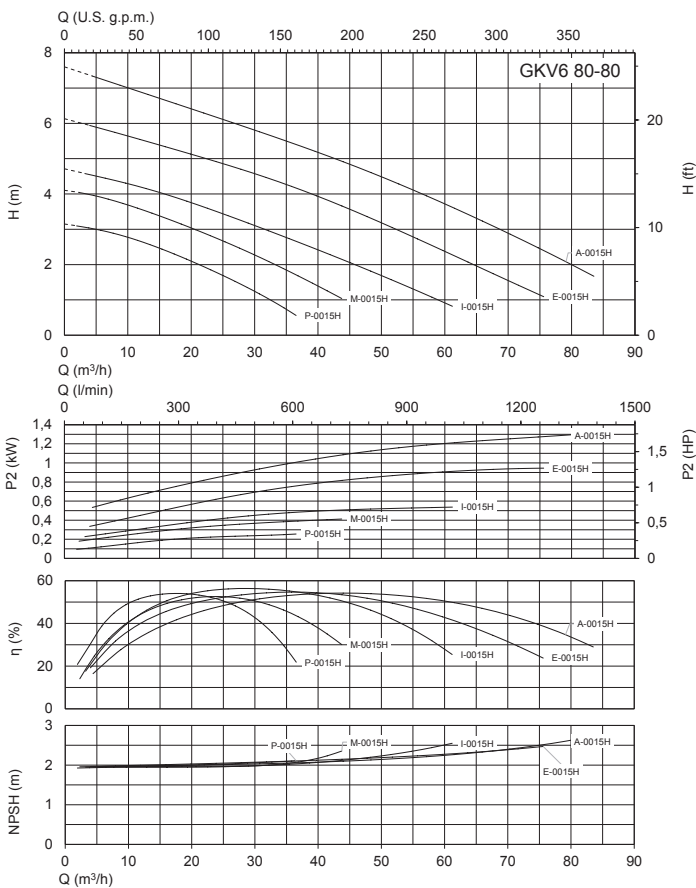
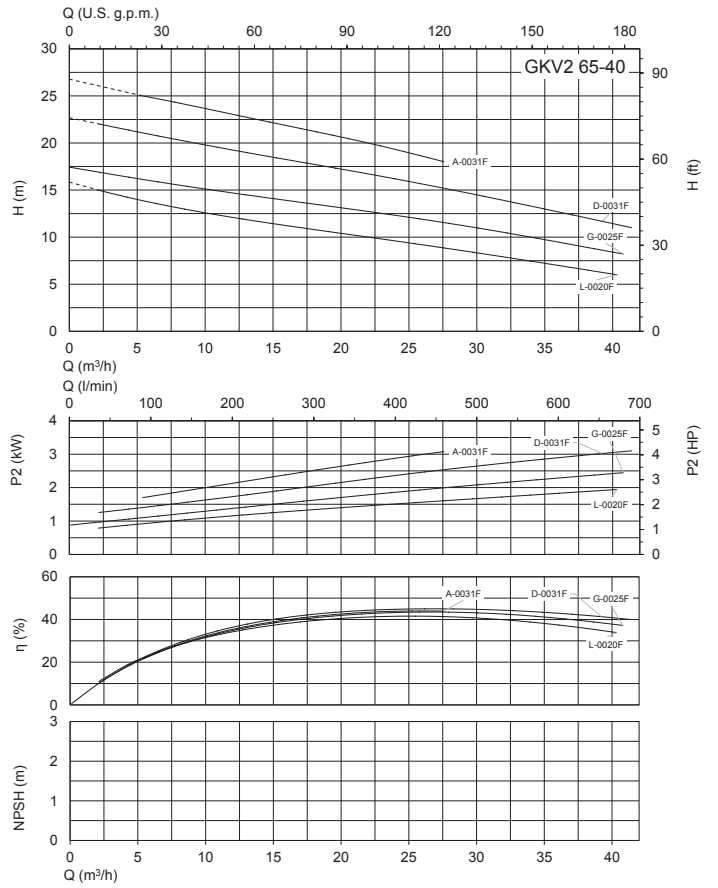
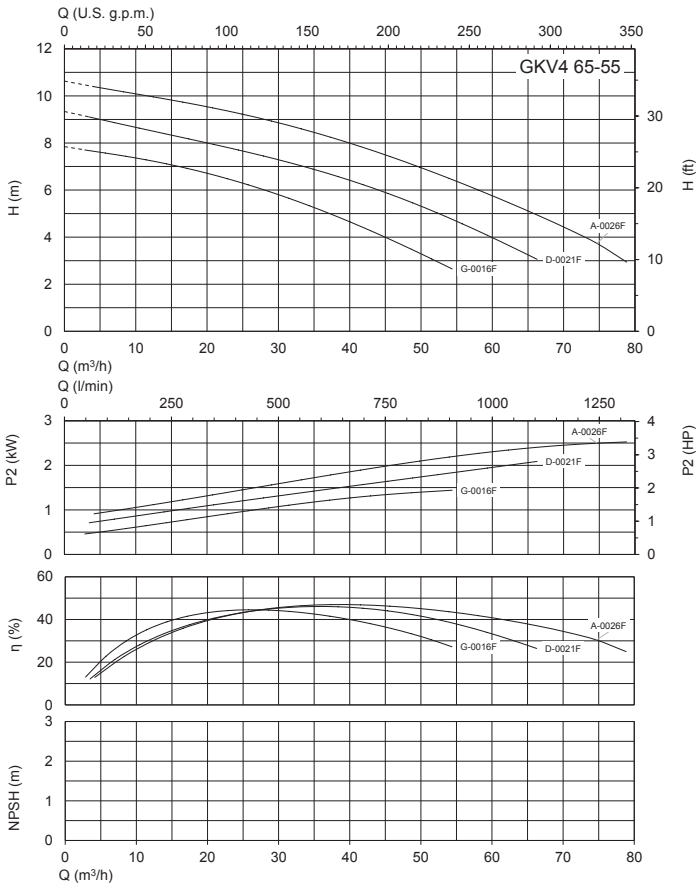

Characteristic curves

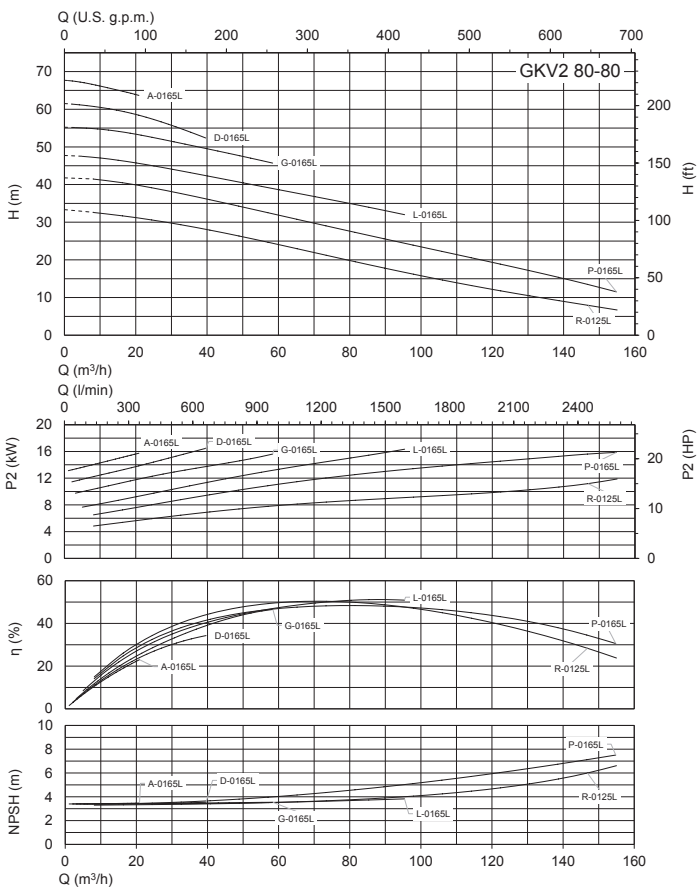
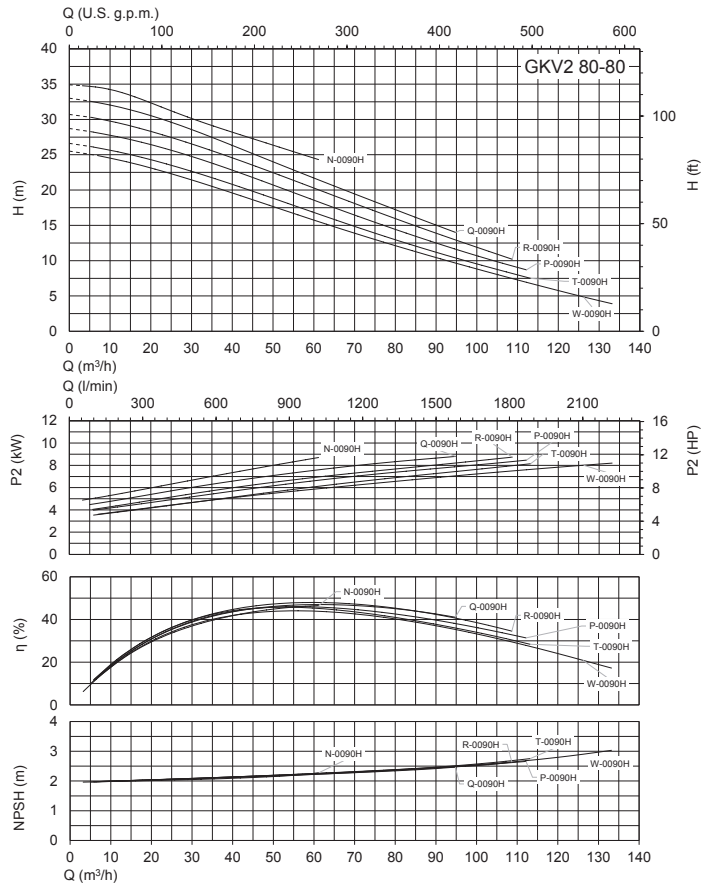
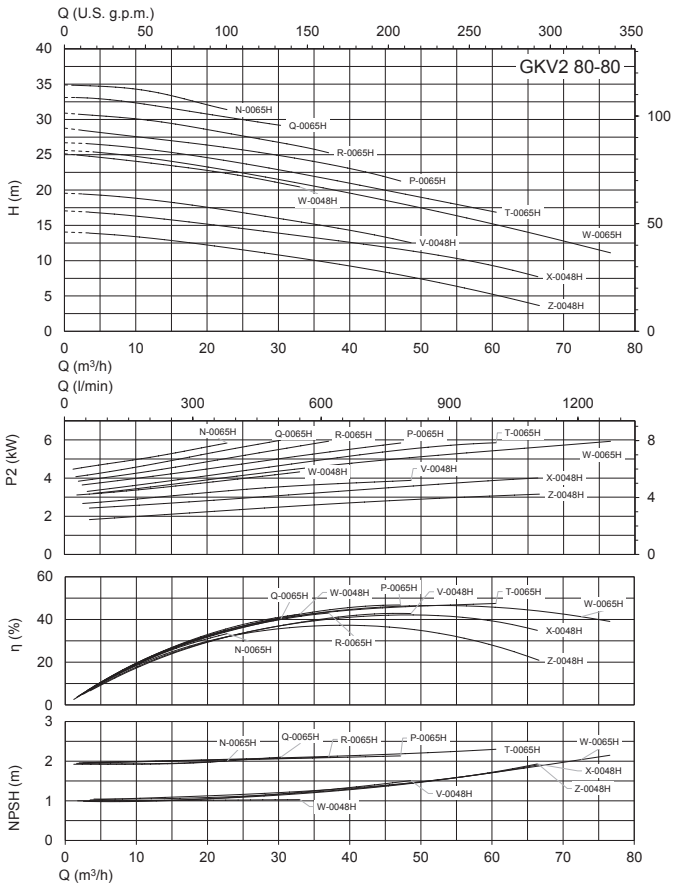

Characteristic curves

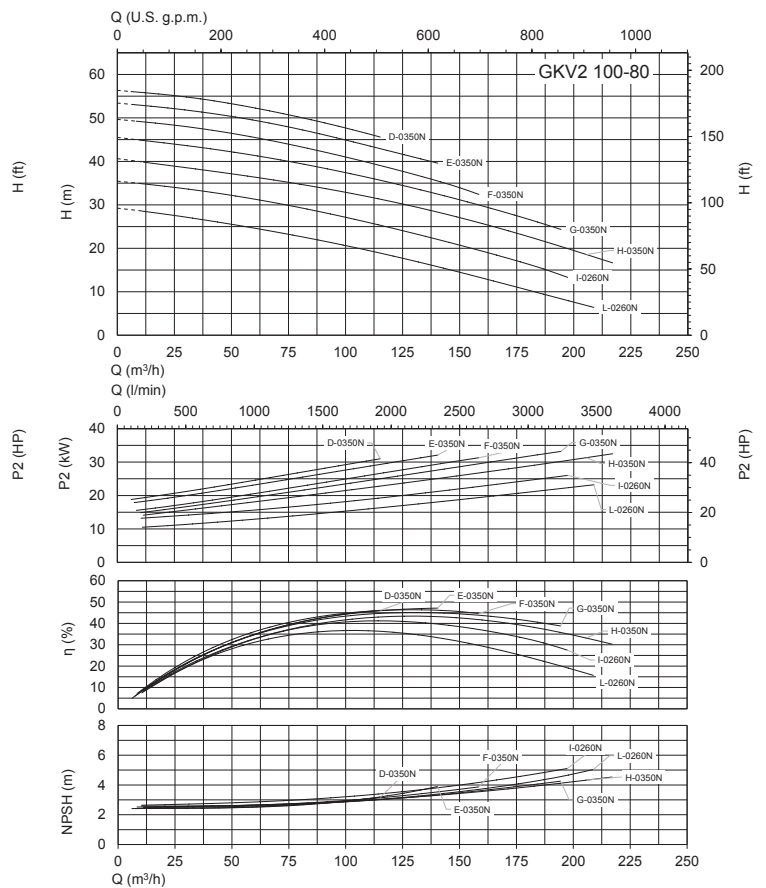
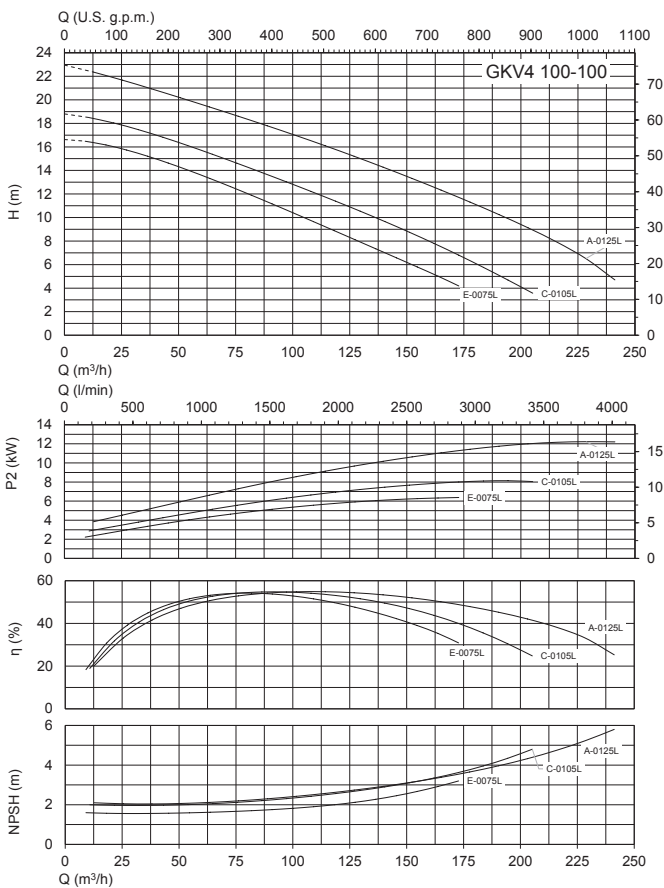
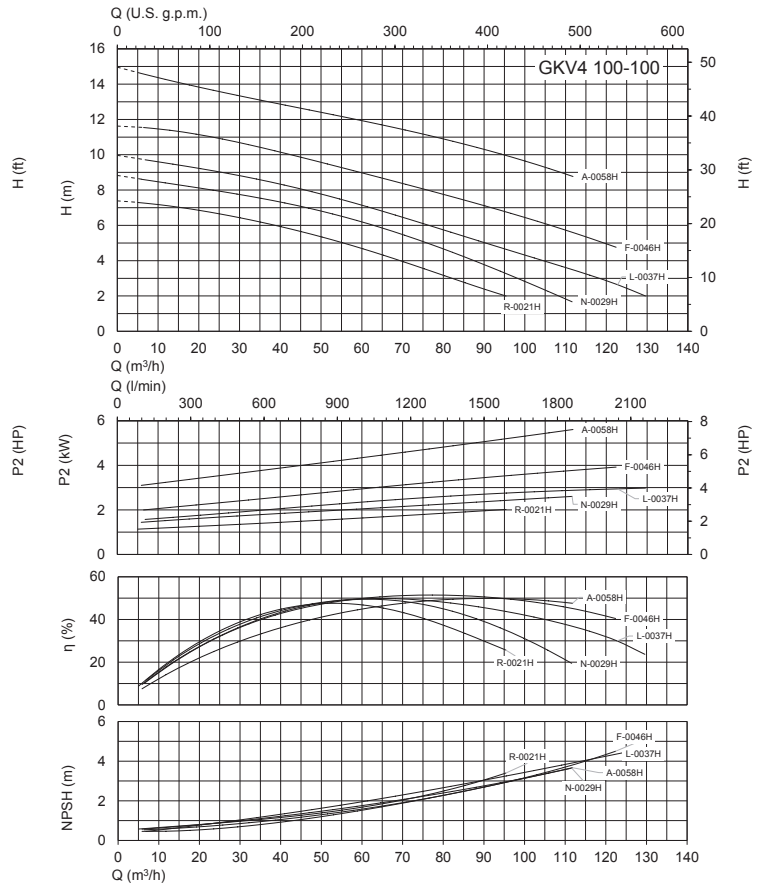
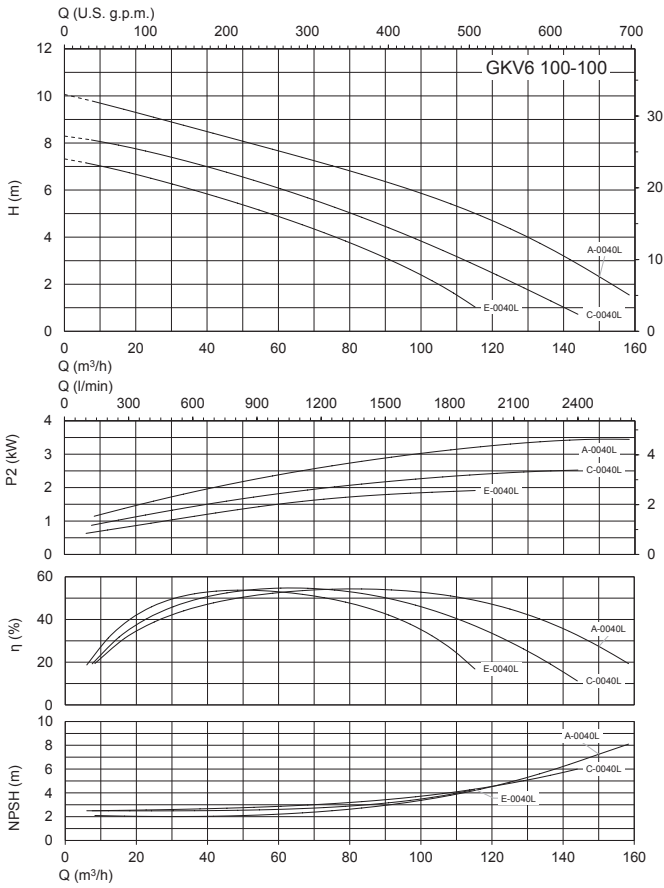

Dimensions and weights

Duck foot coupling

SAK

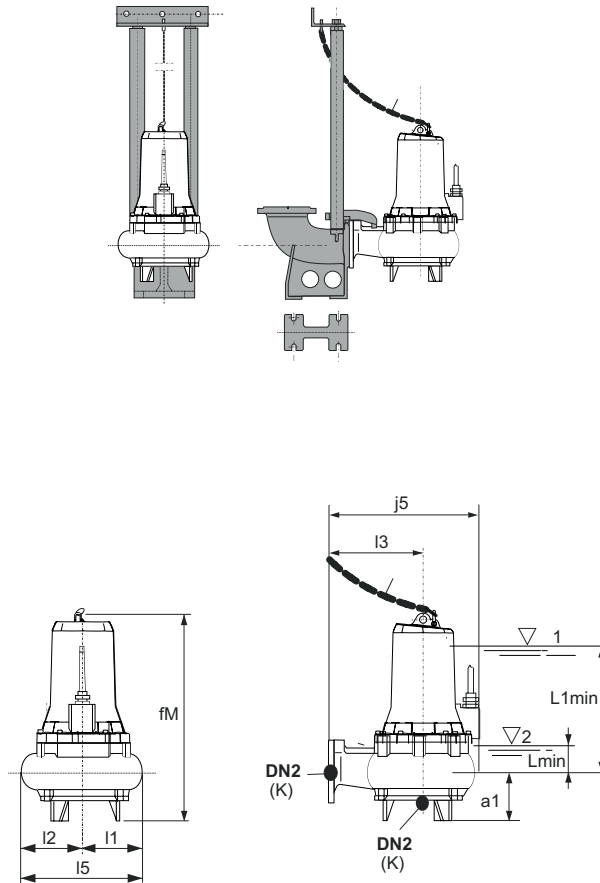

TYPE	DN2	mm									Kg	
		a1	fM	j5	K	l1	l2	l5	l5	L1min	Lmin	Weight
GKV4 65-55G-0016F	65	140	565.6	373	16	148	148	225	296	255	90	63
GKV4 65-55D-0021F	65	140	565.6	373	16	148	148	225	296	255	90	63
GKV4 65-55A-0026F	65	140	565.6	373	16	148	148	225	296	255	90	66
GKV2 65-40L-0020F	65	107.5	529.6	363	16	113	113	225	226	282.5	92.5	54
GKV2 65-40G-0025F	65	107.5	529.6	370	16	113	113	225	226	282.5	92.5	56
GKV2 65-40A-0031F	65	107.5	533.6	370	16	113	113	225	226	282.5	92.5	61
GKV2 65-40D-0031F	65	107.5	533.6	370	16	113	113	225	226	282.5	92.5	60

L1min = Minimum submergence depth for motor without casing with continuous duty S1 (NPSHR permitting)

Lmin = Minimum submergence depth for motor without casing with intermittent duty S3 (NPSHR permitting)

Dimensions and weights

Duck foot coupling

SAK

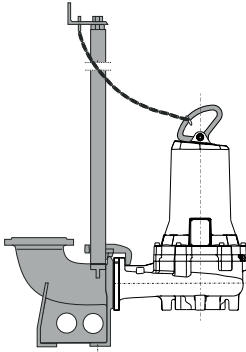

Submersible pump rest

APK

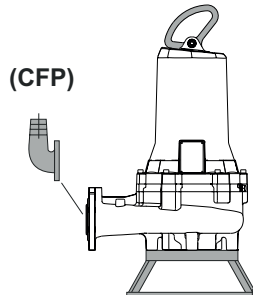

Dry chamber pump rest

APCK

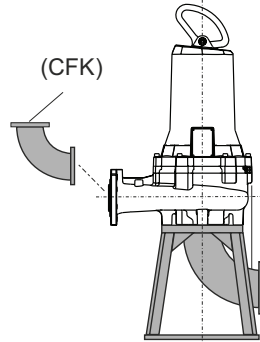

Dry chamber pump support

SOK

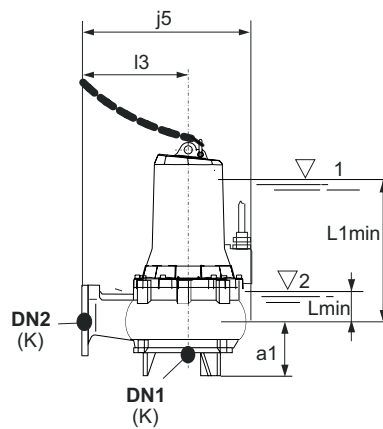
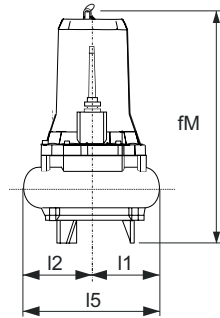
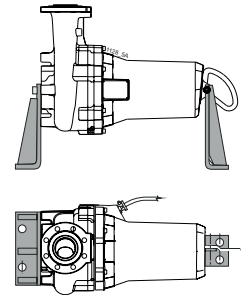

TYPE			mm										Kg Weight
	DN1	DN2	a1	fM	j5	K	l1	l2	l5	l5	L1min	Lmin	
GKV6 80-80P-0015H	80	80	92	638.3	392	16	204.5	146	245	350.5	315	97	83.6
GKV6 80-80M-0015H	80	80	92	638.3	392	16	204.5	146	245	350.5	315	97	84.5
GKV6 80-80I-0015H	80	80	92	638.3	392	16	204.5	146	245	350.5	315	97	81.6
GKV6 80-80E-0015H	80	80	92	638.3	392	16	204.5	146	245	350.5	315	97	86.6
GKV6 80-80A-0015H	80	80	92	638.3	392	16	204.5	146	245	350.5	315	97	82.7
GKV4 80-80P-0016H	80	80	92	638.3	392	16	204.5	146	245	350.5	315	97	87.8
GKV4 80-80M-0016H	80	80	92	638.3	392	16	204.5	146	245	350.5	315	97	88.7
GKV4 80-80I-0021H	80	80	92	638.3	392	16	204.5	146	245	350.5	315	97	90.2
GKV4 80-80H-0029H	80	80	92	638.3	392	16	204.5	146	245	350.5	315	97	89
GKV4 80-80E-0037H	80	80	92	707.4	392	16	221	146	245	367	349	97	109.5
GKV4 80-80C-0046H	80	80	92	707.4	392	16	221	146	245	367	349	97	109.7
GKV4 80-80A-0058H	80	80	92	707.4	392	16	221	146	245	367	349	97	109

L1min = Minimum submergence depth for motor without casing with continuous duty S1 (NPSHR permitting)

Lmin = Minimum submergence depth for motor without casing with intermittent duty S3 (NPSHR permitting)

Dimensions and weights

Duck foot coupling

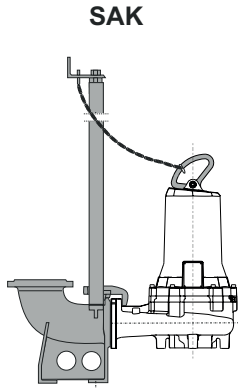

Submersible pump rest

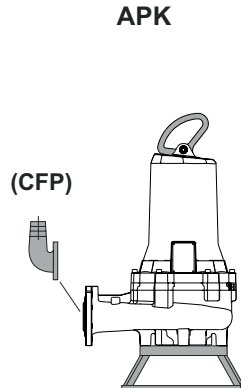

Dry chamber pump rest

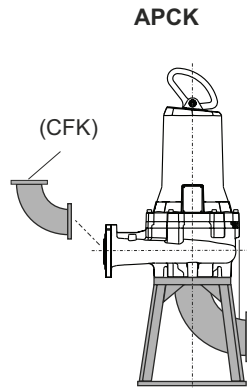

Dry chamber pump support

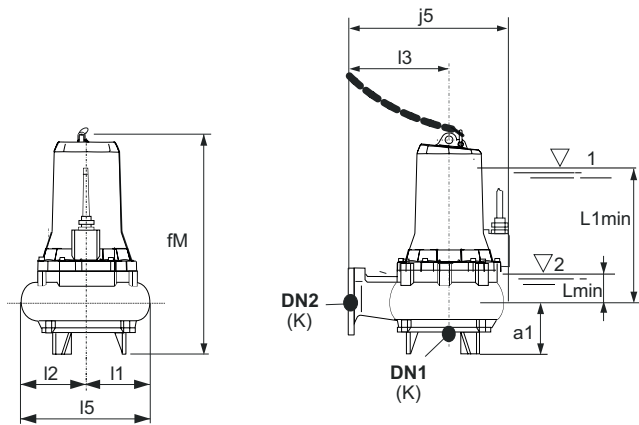
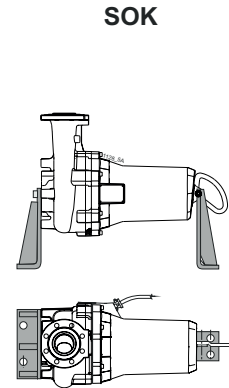

TYPE	DN		mm										Kg Weight
	DN1	DN2	a1	fM	j5	K	l1	l2	l5	l5	L1min	Lmin	
GKV2 80-80V-0048H	80	80	92	638.3	392	16	204.5	146	245	350.5	349	97	92.8
GKV2 80-80X-0048H	80	80	92	638.3	392	16	204.5	146	245	350.5	349	97	92.7
GKV2 80-80Z-0048H	80	80	92	638.3	392	16	204.5	146	245	350.5	349	97	92.5
GKV2 80-80N-0065H	80	80	92	707.4	392	16	221	146	245	367	349	97	112.8
GKV2 80-80P-0065H	80	80	92	707.4	392	16	221	146	245	367	349	97	112.4
GKV2 80-80Q-0065H	80	80	92	707.4	392	16	221	146	245	367	349	97	113
GKV2 80-80R-0065H	80	80	92	707.4	392	16	221	146	245	367	349	97	112.6
GKV2 80-80T-0065H	80	80	92	707.4	392	16	221	146	245	367	349	97	112.6
GKV2 80-80W-0048H	80	80	92	638.3	392	16	204.5	146	245	350.5	349	97	90
GKV2 80-80W-0065H	80	80	92	707.4	392	16	221	146	245	367	349	97	105
GKV2 80-80W-0090H	80	80	92	707.4	392	16	221	146	245	367	349	97	-
GKV2 80-80T-0090H	80	80	92	707.4	392	16	221	146	245	367	349	97	-
GKV2 80-80R-0090H	80	80	92	707.4	392	16	221	146	245	367	349	97	-
GKV2 80-80Q-0090H	80	80	92	707.4	392	16	221	146	245	367	349	97	-
GKV2 80-80P-0090H	80	80	92	707.4	392	16	221	146	245	367	349	97	-
GKV2 80-80N-0090H	80	80	92	707.4	392	16	221	146	245	367	349	97	108
GKV2 80-80L-0125L	80	80	99	775	543	16	225.5	165	370	390.5	446	98	144.2
GKV2 80-80P-0165L	80	80	99	777.4	543	16	236.5	165	370	401.5	446	98	168.5
GKV2 80-80L-0165L	80	80	99	777.4	543	16	236.5	165	370	401.5	446	98	169.1
GKV2 80-80G-0165L	80	80	99	777.4	543	16	236.5	165	370	401.5	446	98	169.4
GKV2 80-80D-0165L	80	80	99	777.4	543	16	236.5	165	370	401.5	446	98	169.7
GKV2 80-80A-0165L	80	80	99	777.4	543	16	236.5	165	370	401.5	446	98	163

L1min = Minimum submergence depth for motor without casing with continuous duty S1 (NPSHR permitting)
 Lmin = Minimum submergence depth for motor without casing with intermittent duty S3 (NPSHR permitting)

Dimensions and weights

Duck foot coupling

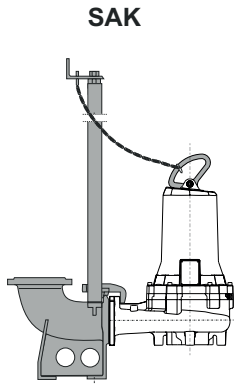

Submersible pump rest

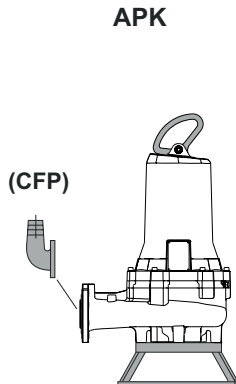

Dry chamber pump rest

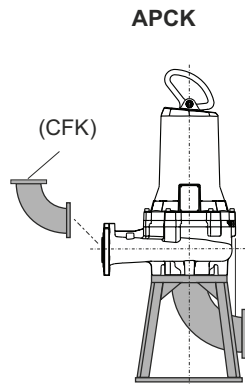

Dry chamber pump support

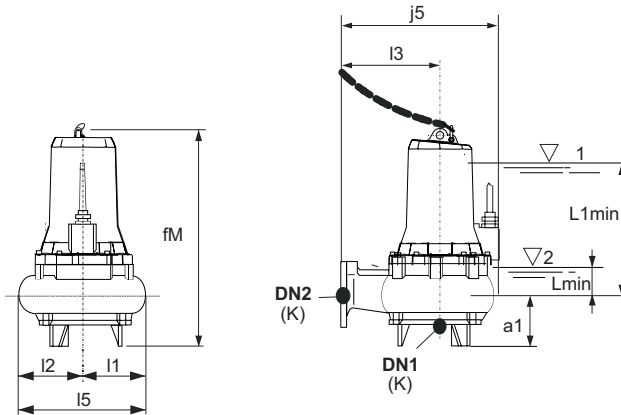
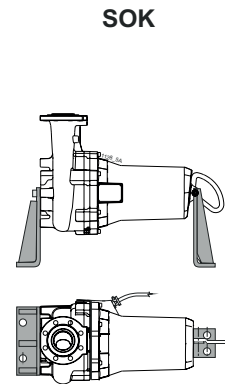

TYPE	mm												Kg Weight
	DN1	DN2	a1	fM	j5	K	l1	l2	l5	l5	L1min	Lmin	
GKV6 100-100E-0040L	100	100	112	798	473	16	225.5	178.5	295	404	468	106	139.9
GKV6 100-100C-0040L	100	100	112	798	473	16	225.5	178.5	295	404	468	106	140.3
GKV6 100-100A-0040L	100	100	112	798	473	16	225.5	178.5	295	404	468	106	140.9
GKV4 100-100R-0021H	100	100	112	668.3	434	16	204.5	171	263	375.5	326	106	96.6
GKV4 100-100N-0029H	100	100	112	668.3	434	16	204.5	171	263	375.5	326	106	96.8
GKV4 100-100L-0037H	100	100	112	737.4	434	16	221	171	263	392	361	106	103
GKV4 100-100F-0046H	100	100	112	737.4	434	16	221	171	263	392	361	106	111.7
GKV4 100-100A-0058H	100	100	112	737.4	434	16	221	171	263	392	361	106	121.2
GKV4 100-100E-0075L	100	100	112	798	473	16	225.5	178.5	295	404	468	106	149
GKV4 100-100C-0105L	100	100	112	800.4	473	16	236	178.5	295	414.5	468	106	172
GKV4 100-100A-0125L	100	100	112	800.4	473	16	236.5	178.5	295	415	468	106	172.6

L1min = Minimum submergence depth for motor without casing with continuous duty S1 (NPSHR permitting)

Lmin = Minimum submergence depth for motor without casing with intermittent duty S3 (NPSHR permitting)

Dimensions and weights

Duck foot coupling

SAK

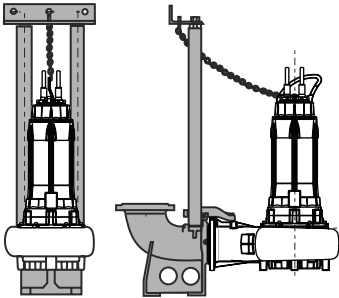

Submersible pump rest

APK

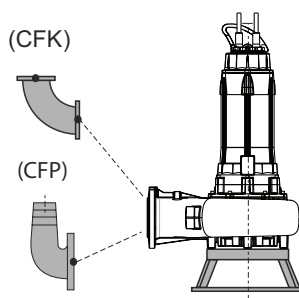

Dry chamber pump rest

APCK

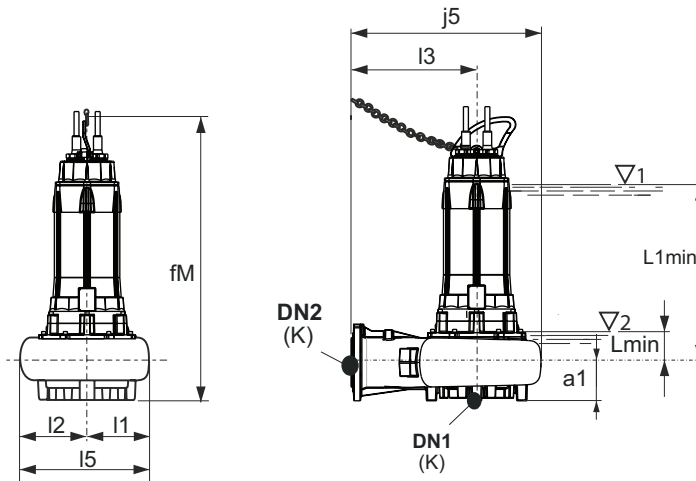
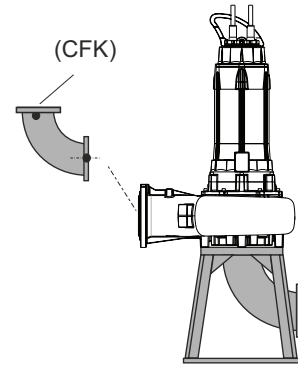

TYPE	mm												Kg Weight
	DN1	DN2	a1	fM	j5	K	l1	l2	l5	l5	L1min	Lmin	
GKV2 100-80L-0260N	100	100	110	1183	553	16	200	200	335	400	788	167	330.7
GKV2 100-80I-0260N	100	100	110	1183	553	16	200	200	335	400	788	167	330.9
GKV2 100-80H-0350N	100	100	110	1183	553	16	200	200	335	400	788	167	354.1
GKV2 100-80G-0350N	100	100	110	1183	553	16	200	200	335	400	788	167	354.2
GKV2 100-80F-0350N	100	100	110	1183	553	16	200	200	335	400	788	167	354.3
GKV2 100-80E-0350N	100	100	110	1183	553	16	200	200	335	400	788	167	349.1
GKV2 100-80D-0350N	100	100	110	1183	553	16	200	200	335	400	788	167	354.6

L1min = Minimum submergence depth for motor without casing with continuous duty S1 (NPSHR permitting)

Lmin = Minimum submergence depth for motor without casing with intermittent duty S3 (NPSHR permitting)

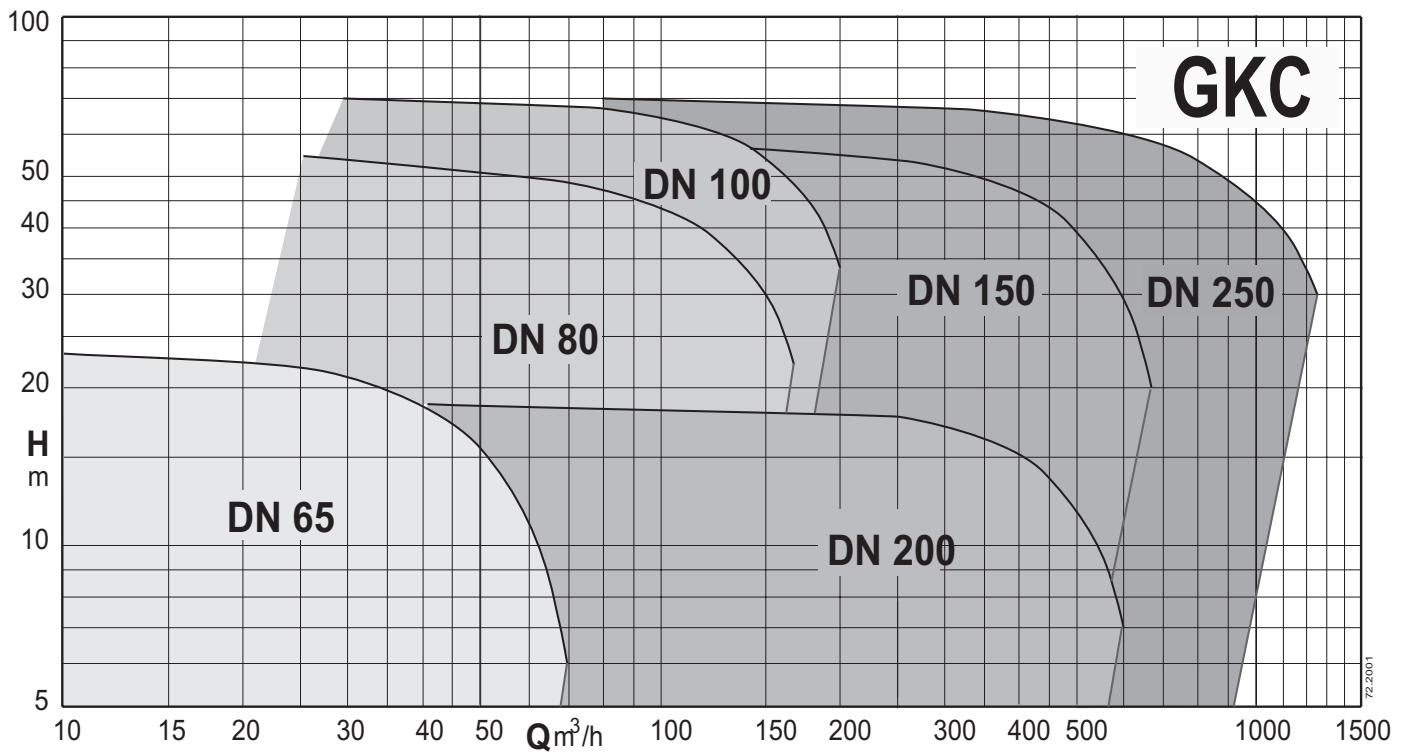

Submersible pumps with single channel impeller

Construction

Submersible pumps with single-channel impeller. It offers reliability against clogging and features wide through sections and a good resistance to wear, low mechanical action on the fluid, high hydraulic efficiency. Low vibrations thanks to the dynamically balanced impeller. Delivery port DN 65-80-100-150-200-250

Applications

Particularly suitable for clean water, water containing solid and fibrous solids, cloacal water, sewage and sludge. Particularly suitable for the emptying of sewage from cesspits or primary collection tanks or industrial waste water. Solid passage from 40 to 163 mm.

Operating conditions

Liquid temperature: from 0°C to +40°C.
Maximum immersion depth: 20m (with cable of suitable length).
Maximum working pressure: 80 m.w.c.
pH of the liquid to be lifted: 4 ÷ 10
Continuous service (with water at minimum immersion level).

Materials

Pump casing: cast iron EN-GJL250 UNI-EN 1561-11
Impeller: cast iron EN-GJL250 UNI-EN 1561-11
Motor casing: cast iron EN-GJL250 UNI-EN 1561-11 / EN-GJL450 UNI-EN 1561-11
Shaft: stainless steel X20Cr13 (AISI420)
Mechanical seal pumps with insulation class H
- motor side: graphite/ceramic
- pump side: silicon/ceramic carbide
Mechanical seal pumps with insulation class F
- motor side: stainless steel/graphite
- pump side: Silicon carbide/silicon carbide

Technical data

TYPE	Dry chamber version		Probes		Cable		Class Isolation /Efficiency	Duck foot coupling	Submersible pump rest	Dry chamber pump rest	Dry chamber pump support
	Vertical	Horizontal	thermal	conductivity	NSSHOU-J	H07RN-F					
GKC2 65-40G-0020F	-	-	o	o	-	•	H / IE3	SAK 65-65-2	-	-	-
GKC2 65-40D-0020F	-	-	o	o	-	•	H / IE3	SAK 65-65-2	-	-	-
GKC2 65-40A-0025F	-	-	o	o	-	•	H / IE3	SAK 65-65-2	-	-	-
GKC2 65-40A-0048H	#	#	o	o	•	-	H / IE3	SAK 65-65-2	APK 80	APCK 65	SOK80/N3
GKC2 65-40D-0048H	#	#	o	o	•	-	H / IE3	SAK 65-65-2	APK 80	APCK 65	SOK80/N3
GKC2 65-40G-0038H	#	#	o	o	•	-	H / IE3	SAK 65-65-2	APK 80	APCK 65	SOK80/N3
GKC2 65-40L-0038H	#	#	o	o	•	-	H / IE3	SAK 65-65-2	APK 80	APCK 65	SOK80/N3
GKC6 80-75G-0015H	#	#	•	•	•	-	H / IE3	SAK 80-80-2	APK 80	APCK 80	SOK80/N3
GKC6 80-75D-0015H	#	#	•	•	•	-	H / IE3	SAK 80-80-2	APK 80	APCK 80	SOK80/N3
GKC6 80-75A-0015H	#	#	•	•	•	-	H / IE3	SAK 80-80-2	APK 80	APCK 80	SOK80/N3
GKC4 80-75A-0029H	#	#	•	•	•	-	H / IE3	SAK 80-80-2	APK 80	APCK 80	SOK80/N3
GKC4 80-76A-0021F	-	-	•	•	•	-	F / IE3	SAK 80-80-2	-	-	-
GKC4 80-76D-0021F	-	-	•	•	•	-	F / IE3	SAK 80-80-2	-	-	-
GKC4 80-76G-0016F	-	-	•	•	•	-	F / IE3	SAK 80-80-2	-	-	-
GKC4 80-76L-0016F	-	-	•	•	•	-	F / IE3	SAK 80-80-2	-	-	-
GKC4 80-80A-0058H	#	#	•	•	•	-	H / IE3	SAK 80-80-2	APK 100	APCK 100	SOK100/N3
GKC4 80-80G-0037H	#	#	•	•	•	-	H / IE3	SAK 80-80-2	APK 100	APCK 100	SOK100/N3
GKC4 80-75G-0016H	#	#	•	•	•	-	H / IE3	SAK 80-80-2	APK 80	APCK 80	SOK80/N3
GKC4 80-75D-0021H	#	#	•	•	•	-	H / IE3	SAK 80-80-2	APK 80	APCK 80	SOK80/N3
GKC4 80-80L-0029H	#	#	•	•	•	-	H / IE3	SAK 80-80-2	APK 100	APCK 100	SOK100/N3
GKC4 80-80D-0046H	#	#	•	•	•	-	H / IE3	SAK 80-80-2	APK 100	APCK 100	SOK100/N3
GKC2 80-80P-0165L	#	#	•	•	•	-	H / IE3	SAK 80-80-2	APK 80	APCK 80	SOK80/N3
GKC2 80-80I-0065L	#	#	•	•	•	-	H / IE3	SAK 80-80-2	APK 80	APCK 80	SOK80/N3
GKC2 80-80G-0065L	#	#	•	•	•	-	H / IE3	SAK 80-80-2	APK 80	APCK 80	SOK80/N3
GKC2 80-80E-0090L	#	#	•	•	•	-	H / IE3	SAK 80-80-2	APK 80	APCK 80	SOK80/N3
GKC2 80-80C-0125L	#	#	•	•	•	-	H / IE3	SAK 80-80-2	APK 80	APCK 80	SOK80/N3
GKC2 80-80A-0125L	#	#	•	•	•	-	H / IE3	SAK 80-80-2	APK 80	APCK 80	SOK80/N3
GKC6 100-80L-0015H	#	#	•	•	•	-	H / IE3	SAK 100-100-2A	APK 100	APCK 100	SOK100/N3
GKC6 100-80G-0015H	#	#	•	•	•	-	H / IE3	SAK 100-100-2A	APK 100	APCK 100	SOK100/N3
GKC6 100-80D-0018H	#	#	•	•	•	-	H / IE3	SAK 100-100-2A	APK 100	APCK 100	SOK100/N3
GKC6 100-80A-0018H	#	#	•	•	•	-	H / IE3	SAK 100-100-2A	APK 100	APCK 100	SOK100/N3

• = Standard
- = Not present

o = Optional

= Version with oil chamber

= In case of operation in a dry chamber or with a low level of the pumped liquid, it is necessary to introduce the cooling oil according to the quantities indicated in the use and maintenance manual

Motor

2,4,6,8 pole, 50Hz induction motor.
Three-phase version: 400V ± 10%, up to 4.8kW
400/690V ± 10% from 5.8kW
Isolation class: F or H
Degree of protection: IP 68
Max number of starts per hour:
- 20 up to 5 kW
- 15 up to 10 kW
- 10 for higher powers

Cable: length 10m
Direction of rotation: clockwise top view
Motor suitable for operation with frequency converter.

Designation

GKC4 100-80A-0058R
GK = Series
C = Single-channel impeller
4 = Number of poles
100 = Delivery port diameter in mm
80 = Free passage in mm
A = Impeller trim
0058 = Motor size kW x 10
R = With cooling jacket

Technical data

TYPE	Dry chamber version		Probes		Cable		Class Isolation	Duck foot coupling	Submersible pump rest	Dry chamber pump rest	Dry chamber pump support
	Vertical	Horizontal	thermal	conductivity	NSSHOU-J	H07RN-F					
GKC4 100-80D-0046H	#	#	•	•	•	-	H / IE3	SAK 100-100-2A	APK 100	APCK 100	SOK100/N3
GKC4 100-80A-0058H	#	#	•	•	•	-	H / IE3	SAK 100-100-2A	APK 100	APCK 100	SOK100/N3
GKC4 100-100L-0165N	#	-	•	•	•	-	H / IE3	SAK 100-100-2	APK 150	APCK 150A	-
GKC4 100-100G-0193N	#	-	•	•	•	-	H / IE3	SAK 100-100-2	APK 150	APCK 150A	-
GKC4 100-100D-0193N	#	-	•	•	•	-	H / IE3	SAK 100-100-2	APK 150	APCK 150A	-
GKC4 100-100A-0230N	#	-	•	•	•	-	H / IE3	SAK 100-100-2	APK 150	APCK 150A	-
GKC4 100-80L-0029H	#	#	•	•	•	-	H / IE3	SAK 100-100-2A	APK 100	APCK 100	SOK100/N3
GKC4 100-80G-0037H	#	#	•	•	•	-	H / IE3	SAK 100-100-2A	APK 100	APCK 100	SOK100/N3
GKC2 100-80C-0260N	#	-	•	•	•	-	H	SAK 100-100-2A	APK 100A	APCK 100	-
GKC2 100-80D-0260N	#	-	•	•	•	-	H	SAK 100-100-2A	APK 100A	APCK 100	-
GKC2 100-80G-0260N	#	-	•	•	•	-	H	SAK 100-100-2A	APK 100A	APCK 100	-
GKC2 100-80F-0260N	#	-	•	•	•	-	H	SAK 100-100-2A	APK 100A	APCK 100	-
GKC2 100-80E-0260N	#	-	•	•	•	-	H	SAK 100-100-2A	APK 100A	APCK 100	-
GKC2 100-80C-0350N	#	-	•	•	•	-	H	SAK 100-100-2A	APK 100A	APCK 100	-
GKC2 100-80D-0350N	#	-	•	•	•	-	H	SAK 100-100-2A	APK 100A	APCK 100	-
GKC2 100-80B-0350N	#	-	•	•	•	-	H	SAK 100-100-2A	APK 100A	APCK 100	-
GKC2 100-80A-0350N	#	-	•	•	•	-	H	SAK 100-100-2A	APK 100A	APCK 100	-
GKC6 150-100G-0040L	#	#	•	•	•	-	H	SAK 150-150-2	APK 150	APCK 150A	SOK150/N3
GKC6 150-100D-0040L	#	#	•	•	•	-	H	SAK 150-150-2	APK 150	APCK 150A	SOK150/N3
GKC6 150-100A-0040L	#	#	•	•	•	-	H	SAK 150-150-2	APK 150	APCK 150A	SOK150/N3
GKC4 150-80D-0046H	#	#	•	•	•	-	H	SAK 150-150-2	APK 150	APCK 150A	SOK150/N3
GKC4 150-80A-0058H	#	#	•	•	•	-	H	SAK 150-150-2	APK 150	APCK 150A	SOK150/N3
GKC4 150-100G-0075L	#	#	•	•	•	-	H	SAK 150-150-3	APK 150	APCK 150A	SOK150/N3
GKC4 150-100D-0105L	#	#	•	•	•	-	H	SAK 150-150-4	APK 150	APCK 150A	SOK150/N3
GKC4 150-100A-0125L	#	#	•	•	•	-	H	SAK 150-150-5	APK 150	APCK 150A	SOK150/N3
GKC4 150-115L-0165N	#	-	•	•	•	-	H	SAK 150-200-3	APK 150	APCK 150A	-
GKC4 150-115G-0193N	#	-	•	•	•	-	H	SAK 150-200-3	APK 150	APCK 150A	-
GKC4 150-115D-0210N	#	-	•	•	•	-	H	SAK 150-200-3	APK 150	APCK 150A	-
GKC4 150-115A-0260N	#	-	•	•	•	-	H	SAK 150-200-3	APK 150	APCK 150A	-
GKC4 150-102L-0340R	-	-	•	•	-	•	F	SAK 150-200-3	APK 150A	-	-
GKC4 150-102G-0420R	-	-	•	•	-	•	F	SAK 150-200-3	APK 150A	-	-
GKC4 150-102D-0510R	-	-	•	•	-	•	F	SAK 150-200-3	APK 150A	-	-
GKC4 150-102A-0620R	-	-	•	•	-	•	F	SAK 150-200-3	APK 150A	-	-
GKC4 150-102L-0340R-R	\$	\$	•	•	-	•	F	SAK 150-200-3	-	APCK 150	SOK150-200
GKC4 150-102G-0420R-R	\$	\$	•	•	-	•	F	SAK 150-200-3	-	APCK 150	SOK150-200
GKC4 150-102D-0510R-R	\$	\$	•	•	-	•	F	SAK 150-200-3	-	APCK 150	SOK150-200
GKC4 150-102A-0620R-R	\$	\$	•	•	-	•	F	SAK 150-200-3	-	APCK 150	SOK150-225
GKC6 200-135G-0110P	#	-	•	•	•	-	H	SAK 200-250-3	APK 150	APCK 200	-
GKC6 200-135D-0150P	#	-	•	•	•	-	H	SAK 200-250-3	APK 150	APCK 200	-
GKC6 200-135A-0195P	#	-	•	•	•	-	H	SAK 200-250-3	APK 150	APCK 200	-
GKC8 250-163A-0210Z	-	-	•	•	-	•	F	SAK 250-300-3	APK 350	-	-
GKC6 250-163L-0250R	-	-	•	•	-	•	F	SAK 250-300-3	APK 350	-	-
GKC6 250-163G-0340R	-	-	•	•	-	•	F	SAK 250-300-3	APK 350	-	-
GKC6 250-163D-0420R	-	-	•	•	-	•	F	SAK 250-300-3	APK 350	-	-
GKC6 250-163A-0510R	-	-	•	•	-	•	F	SAK 250-300-3	APK 350	-	-
GKC8 250-163A-0210Z-R	\$	\$	•	•	-	•	F	SAK 250-300-3	-	APCK 250A	SOK350-200
GKC6 250-163L-0250R-R	\$	\$	•	•	-	•	F	SAK 250-300-3	-	APCK 250A	SOK350-200
GKC6 250-163G-0340R-R	\$	\$	•	•	-	•	F	SAK 250-300-3	-	APCK 250A	SOK350-200
GKC6 250-163D-0420R-R	\$	\$	•	•	-	•	F	SAK 250-300-3	-	APCK 250A	SOK350-200
GKC6 250-163A-0510R-R	\$	\$	•	•	-	•	F	SAK 250-300-3	-	APCK 250A	SOK350-250
GKC4 250-163M-0820T	-	-	•	•	-	•	F	SAK 250-300-3A	APK 350	-	-
GKC4 250-163L-1000T	-	-	•	•	-	•	F	SAK 250-300-3A	APK 350	-	-
GKC4 250-163H-1000T	-	-	•	•	-	•	F	SAK 250-300-3A	APK 350	-	-
GKC4 250-163G-1200T	-	-	•	•	-	•	F	SAK 250-300-3A	APK 350	-	-
GKC4 250-163E-1450T	-	-	•	•	-	•	F	SAK 250-300-3A	APK 350	-	-
GKC4 250-163T-1450T	-	-	•	•	-	•	F	SAK 250-300-3A	APK 350	-	-
GKC4 250-163B-1450T	-	-	•	•	-	•	F	SAK 250-300-3A	APK 350	-	-
GKC4 250-163A-1800T	-	-	•	•	-	•	F	SAK 250-300-3A	APK 350	-	-
GKC4 250-163M-0820T-R	\$	-	•	•	-	•	F	SAK 250-300-3A	-	APCK 250A	SOK350-250
GKC4 250-163L-1000T-R	\$	-	•	•	-	•	F	SAK 250-300-3A	-	APCK 250A	SOK350-280
GKC4 250-163H-1000T-R	\$	-	•	•	-	•	F	SAK 250-300-3A	-	APCK 250A	SOK350-280
GKC4 250-163G-1200T-R	\$	-	•	•	-	•	F	SAK 250-300-3A	-	APCK 250A	SOK350-280
GKC4 250-163E-1450T-R	\$	-	•	•	-	•	F	SAK 250-300-3A	-	APCK 250A	SOK350-280
GKC4 250-163T-1450T-R	\$	-	•	•	-	•	F	SAK 250-300-3A	-	APCK 250A	SOK350-280
GKC4 250-163B-1450T-R	\$	-	•	•	-	•	F	SAK 250-300-3A	-	APCK 250A	SOK350-280
GKC4 250-163A-1800T-R	\$	-	•	•	-	•	F	SAK 250-300-3A	-	APCK 250A	SOK350-315

• = Standard o = Optional # = Version with oil chamber # = In case of operation in a dry chamber or with a low level of the pumped liquid, it is necessary to introduce the cooling oil according to the quantities indicated in the use and maintenance manual
 - = Not present \$ = Version with cooling jacket

Performance

n ≈ 2850 1/min

Model	400V A	P2 kW	Q = Flow																		
			m³/h	0																	
			l/min	10,8	14,4	18	21,5	25,2	28,8	32,4	36	43,2	45	50,4	54	57,6	63	64,8	72	81	90
GKC2 65-40G-0020F	4,1	2	19,5	16,1	15,2	14,4	13,5	12,7	12	11,2	10,4	8,9	-	7,2	-	-	-	-	-	-	
GKC2 65-40D-0020F	4,1	2	24,1	18,1	17,2	16,4	15,5	14,7	13,8	13	12,2	10,4	-	8,6	-	6,7	-	-	-	-	
GKC2 65-40A-0025F	5,5	2,5	27,9	21,8	20,7	19,7	18,8	17,9	17	16,2	15,3	13,6	-	11,8	-	9,8	-	7,7	5,3	-	
GKC2 65-40L-0038H	7,5	3,8	25	20,8	19,8	18,8	17,8	16,9	16	15,1	14,3	-	12,1	-	9,8	-	7,1	-	-	-	
GKC2 65-40G-0038H	7,5	3,8	26,2	-	22,6	21,7	20,8	20	19,1	18,2	17,3	-	15	-	12,6	-	10,1	-	7,5	-	
GKC2 65-40D-0048H	8,9	4,8	31	27,9	26,8	25,8	24,9	24	23,2	22,4	21,5	-	19,4	-	17,2	-	14,9	-	12,5	10,2	7,9
GKC2 65-40A-0048H	8,9	4,8	35	-	29,5	28,3	27,3	26,4	25,7	24,9	24,1	-	22,1	-	19,8	-	-	-	-	-	-

n ≈ 950 1/min

Model	400V A	P2 kW	HP	Q = Flow																
				m³/h	0															
				l/min	18	21,5	25,2	28,8	32,4	36	43,2	50,4	57,6	64,8	72	79,2				
GKC6 80-75G-0015H	3,4	1,5	2	4,3	3,6	3,4	3,2	3	2,9	2,7	2,3	1,8	1,3	0,7	-	-	-	-	-	-
GKC6 80-75D-0015H	3,4	1,5	2	5,7	4,3	4,2	4	3,9	3,7	3,5	3,1	2,7	2,2	1,7	-	-	-	-	-	-
GKC6 80-75A-0015H	3,4	1,5	2	7,2	-	5,5	5,3	5,1	4,9	4,7	4,3	3,9	3,5	3,1	2,5	1,9	-	-	-	-

n ≈ 1450 1/min

Model	400V A	P2 kW	Q = Flow																	
			m³/h	0																
			l/min	21,5	25,2	28,8	32,4	36	45	54	63	72	81	90	99	108				
GKC4 80-76L-0016F	3,7	1,6	9,6	-	-	6,8	6,6	6,4	6	5,4	4,9	4,3	3,7	3,2	-	-	-	-	-	-
GKC4 80-76G-0016F	3,7	1,6	11	8,2	8	7,8	7,6	7,4	6,8	6,3	5,7	5,1	4,4	3,7	-	-	-	-	-	-
GKC4 80-76D-0021F	5,1	2,1	12,6	9,3	9,1	9	8,8	8,6	8,1	7,5	6,9	6,3	5,6	4,9	4,2	3,5	-	-	-	-
GKC4 80-76A-0021F	5,1	2,1	13,9	10,5	10,2	10	9,8	9,7	9,2	8,7	8,1	7,5	6,9	-	-	-	-	-	-	-

Model	400V A	400V A	690V A	P2 kW	Q = Flow															
					m³/h	0														
					l/min	18	21,5	28,8	36	54	72	90	108	126	144	162	180	198	216	
GKC4 80-75G-0016H	3,4	-	-	1,6	10,8	-	8,1	7,5	6,1	4,7	3,2	-	-	-	-	-	-	-	-	-
GKC4 80-75D-0021H	5,0	-	-	2,1	13,2	10,2	9,8	9,4	8,3	6,8	5,1	-	-	-	-	-	-	-	-	-
GKC4 80-75A-0029H	6,1	-	-	2,9	15,9	13,2	12,6	12	10,5	9,1	7,6	5,8	-	-	-	-	-	-	-	-
GKC4 80-80L-0029H	6,1	-	-	2,9	14,9	-	-	10,2	9,1	7,7	6,2	4,7	3	-	-	-	-	-	-	-
GKC4 80-80G-0037H	7,7	-	-	3,7	16,8	12,7	12,3	11,9	10,8	9,6	8,2	6,6	5	3,3	-	-	-	-	-	-
GKC4 80-80D-0046H	9,5	-	-	4,6	19,3	-	14,5	13,9	12,8	11,7	10,5	9,1	7,5	5,9	4,1	-	-	-	-	-
GKC4 80-80A-0058H	-	11,9	6,9	5,8	21,4	-	-	16,7	15,6	14,4	13,2	12	10,5	8,9	7,2	5,3	3,4	1,3	-	-

n ≈ 2850 1/min

Model	400V A	690V A	P2 kW	Q = Flow																
				m³/h	0															
				l/min	18	21,5	28,8	36	54	72	90	108	126	144	162					
GKC2 80-80P-0165L	31	17,9	16,5	62,9	-	-	53,6	51	45,9	42	38,8	35,6	32,1	28,1	22,9	-	-	-	-	-
GKC2 80-80I-0065L	11,8	6,8	6,5	28,1	-	22,1	20,3	18,7	15,4	12,7	10,2	7,5	4,6	-	-	-	-	-	-	-
GKC2 80-80G-0065L	11,8	6,8	6,5	33,9	-	28,3	26,3	24,7	21,7	18,9	15,8	12,6	9,5	-	-	-	-	-	-	-
GKC2 80-80E-0090L	16,1	9,3	9	42,1	36,1	34,8	32,5	30,5	27	24,3	21,3	17,5	13,3	-	-	-	-	-	-	-
GKC2 80-80C-0125L	22,4	12,9	12,5	47,9	41,3	40,1	37,7	35,6	31,4	28,2	25	21,3	17,3	13,4	-	-	-	-	-	-
GKC2 80-80A-0125L	22,4	12,9	12,5	53,6	-	46,1	43,5	41,2	36,9	33,9	30,9	27	22,4	17,6	-	-	-	-	-	-

n ≈ 950 1/min

Model	400V A	P2 kW	Q = Flow																	
			m³/h	0																
			l/min	21,5	25,2	28,8	32,4	36	45	54	63	72	81	90	99	108	117	126	135	
GKC6 100-80L-0015H	3,4	1,5	5,4	4,7	4,6	4,5	4,3	4,2	3,9	3,5	3,2	2,8	2,5	2,1	-	-	-	-	-	-
GKC6 100-80G-0015H	3,4	1,5	7,2	5,5	5,4	5,2	5,1	4,9	4,5	4,2	3,8	3,5	3,1	2,6	2,1	1,5	-	-	-	-
GKC6 100-80D-0018H	4,1	1,8	8,7	6,8	6,6	6,4	6,3	6,1	5,7	5,4	5	4,6	4,3	3,9	3,5	3,1	2,7	2,2	-	-
GKC6 100-80A-0018H	4,1	1,8	9,5	7,5	7,4	7,3	7,2	7	6,7	6,4	6,1	5,7	5,4	5	4,6	4,1	3,7	3,2	2,6	-

Performance

n ≈ 1450 1/min

Model	400V A	400V A	690V A	P2 kW	Q = Flow																		
					m ³ /h																		
					0	28,8	36	54	72	90	108	126	144	162	180	198	216	234	252	270			
GKC4 100-80L-0029H	6,1	-	-	2,9	14,3	-	10,1	9,1	8	6,9	5,8	4,6	-	-	-	-	-	-	-				
GKC4 100-80G-0037H	7,7	-	-	3,7	16,9	12,6	12,2	11,3	10,2	9,2	8	6,8	5,5	-	-	-	-	-	-				
GKC4 100-80D-0046H	9,5	-	-	4,6	19,3	-	13,9	13	12	11	10	8,9	7,7	6,5	-	-	-	-	-				
GKC4 100-80A-0058H	-	11,9	6,9	5,8	21,2	17,7	16,9	15,5	14,4	13,4	12,3	11,2	10	8,6	7,1	5,4	3,7	-	-				
GKC4 100-100L-0165N	-	31,2	18	16,5	27,4	-	-	-	21,4	20,7	20	19,3	18,5	17,7	16,8	15,7	14,6	13,4	12	10,7			
GKC4 100-100G-0193N	-	38,8	22,4	19,3	31	-	-	-	24,9	24,1	23,3	22,4	21,5	20,6	19,6	18,6	17,5	16,3	15,1	13,8			
GKC4 100-100D-0193N	-	38,8	22,4	19,3	34,3	-	-	-	29	27,6	26,4	25,2	24,1	23	21,9	20,8	19,7	18,5	17,3	16			
GKC4 100-100A-0230N	-	42,4	24,5	23	39,6	-	-	-	34	32,7	31,4	30,1	29	27,9	26,8	25,7	24,7	23,5	22,3	-			

n ≈ 2850 1/min

Model	400V A	690V A	P2 kW	Q = Flow																
				m ³ /h																
				0	28,8	36	54	72	90	108	126	144	162	180	198					
GKC2 100-80C-0260N	44,6	25,7	26	73,7	-	-	56,2	53,1	49,9	46,6	-	-	-	-	-	-	-	-	-	-
GKC2 100-80D-0260N	44,6	25,7	26	67,9	-	53,7	50,8	47,9	45	42,2	39,4	36,6	-	-	-	-	-	-	-	-
GKC2 100-80G-0260N	44,6	25,7	26	49,4	39	37,6	34,7	31,9	29,2	26,4	23,5	20,7	17,7	14,6	11,4	-	-	-	-	-
GKC2 100-80F-0260N	44,6	25,7	26	54,5	44,6	42,6	39,1	36,2	33,4	30,6	27,8	24,8	21,8	18,8	15,7	-	-	-	-	-
GKC2 100-80E-0260N	44,6	25,7	26	59,3	-	46,6	43,7	40,9	38,2	35,4	32,5	29,6	26,7	23,6	-	-	-	-	-	-
GKC2 100-80C-0350N	57,8	33,4	35	73,9	-	-	56,3	53,3	50,3	47,2	44,1	40,9	37,7	34,6	-	-	-	-	-	-
GKC2 100-80D-0350N	57,8	33,4	35	68	-	54,3	51,5	48,6	45,8	42,9	39,9	36,9	33,9	30,8	-	-	-	-	-	-
GKC2 100-80B-0350N	57,8	33,4	35	77	-	-	59,3	56,1	53,1	50,2	47,4	44,7	41,9	39	-	-	-	-	-	-
GKC2 100-80A-0350N	57,8	33,4	35	80,1	-	-	66,2	61,9	58,4	55,4	52,6	49,9	47	-	-	-	-	-	-	-

n ≈ 950 1/min

Model	400V A	P2 kW	Q = Flow																	
			m ³ /h																	
			0	10,8	14,4	21,5	28,8	36	54	72	90	108	126	144	162	180	198	216		
GKC6 150-100G-0040L	9	4	9,3	-	-	-	-	7,3	6,8	6,2	5,7	5	4,4	3,7	3	-	-	-	-	-
GKC6 150-100D-0040L	9	4	10,9	10	9,7	9,2	8,8	8,5	7,8	7,3	6,8	6,3	5,7	5,1	4,4	3,6	-	-	-	-
GKC6 150-100A-0040L	9	4	12,4	-	-	-	-	9,8	9,1	8,6	8,1	7,6	7,1	6,5	5,9	5,2	4,5	3,7	-	-

n ≈ 1450 1/min

Model	400V A	400V A	690V A	P2 kW	Q = Flow																											
					m ³ /h																											
					0	54	72	90	108	126	144	162	180	198	216	234	252	270	288	324	360	450	540	630								
GKC4 150-80D-0046H	9,5	-	-	4,6	12,1	10,4	9,8	9,1	8,3	7,6	6,9	6,2	5,5	4,8	4	-	-	-	-	-	-	-	-	-	-	-	-	-				
GKC4 150-80A-0058H	-	11,9	6,9	5,8	18,1	13,5	12,8	12,1	11,3	10,5	9,8	9	8,2	7,4	6,6	5,8	4,9	3,9	-	-	-	-	-	-	-	-	-	-				
GKC4 150-100G-0075L	-	15,3	8,8	7,5	20,2	16	14,9	14,1	13,4	12,6	11,8	10,9	10	-	8,1	-	6,1	-	-	-	-	-	-	-	-	-	-	-				
GKC4 150-100D-0105L	-	20	11,5	10,5	24,1	19	18,3	17,6	16,8	16	15,1	14,3	13,4	-	11,6	-	9,7	-	7,6	5,1	-	-	-	-	-	-	-	-				
GKC4 150-100A-0125L	-	24	13,9	12,5	28,9	23	21,6	20,7	19,9	19,1	18,4	17,6	16,8	-	15	-	13	-	10,9	8,5	5,5	-	-	-	-	-	-	-				
GKC4 150-115L-0165N	-	31,2	18	16,5	27,6	-	21,7	20,8	20,1	19,3	18,6	17,9	17,1	-	15,6	-	14	-	12,2	10,4	8,5	-	-	-	-	-	-	-				
GKC4 150-115G-0193N	-	38,8	22,4	19,3	32	-	26,1	24,9	23,8	22,9	22	21,2	20,4	-	18,8	-	17,1	-	15,3	13,4	11,3	-	-	-	-	-	-	-				
GKC4 150-115D-0210N	-	39	22,5	21	34,9	-	28,4	27,3	26,4	25,6	24,8	24	23,2	-	21,5	-	19,7	-	17,8	15,7	13,6	-	-	-	-	-	-	-				
GKC4 150-115A-0260N	-	47,2	27,3	26	39,9	-	33	31,7	30,6	29,7	28,8	27,9	27,1	-	25,4	-	23,7	-	21,9	20	18	11,9	-	-	-	-	-	-				
GKC4 150-102L-0340R	-	65,8	37,6	34	45,5	-	-	-	35,8	34,5	33,4	32,3	31,2	-	29,3	-	27,5	-	25,9	24,2	22,5	17,8	12,5	7,1	-	-	-	-				
GKC4 150-102G-0420R	-	80,5	46,0	42	51,7	-	-	-	41,3	40,1	39	37,9	36,8	-	34,8	-	32,9	-	31,1	29,3	27,5	22,8	17,2	10,6	-	-	-	-				
GKC4 150-102D-0510R	-	93,5	53,4	51	58	-	-	-	46,8	45,6	44,5	43,4	42,3	-	40,3	-	38,4	-	36,5	34,7	32,8	28	22,1	15,1	-	-	-	-				
GKC4 150-102A-0620R	-	117	66,9	62	64,8	-	-	-	52	50,7	49,7	48,7	47,8	-	45,9	-	44,1	-	42,2	40,3	38,4	33,5	27,8	20,8	-	-	-	-				
GKC4 150-102L-0340R-R	-	65,8	37,6	34	45,5	-	-	-	35,8	34,5	33,4	32,3	31,2	-	29,3	-	27,5	-	25,9	24,2	22,5	17,8	12,5	7,1	-	-	-	-				
GKC4 150-102G-0420R-R	-	80,5	46,0	42	51,7	-	-	-	41,3	40,1	39	37,9	36,8	-	34,8	-	32,9	-	31,1	29,3	27,5	22,8	17,2	10,6	-	-	-	-				
GKC4 150-102D-0510R-R	-	93,5	53,4	51	58	-	-	-	46,8	45,6	44,5	43,4	42,3	-	40,3	-	38,4	-	36,5	34,7	32,8	28	22,1	15,1	-	-	-	-				
GKC4 150-102A-0620R-R	-	117	66,9	62	64,8	-	-	-	52	50,7	49,7	48,7	47,8	-	45,9	-	44,1	-	42,2	40,3	38,4	33,5	27,8	20,8	-	-	-	-				

Performance

n ≈ 950 1/min

Model	400V	690V	P2	Q = Flow															
				m³/h	0	90	108	126	144	162	180	216	252	288	324	360	450	540	
						l/min	1500	1800	2100	2400	2700	3000	3600	4200	4800	5400	6000	7500	9000
A				H (m) = Total head															
GKC6 200-135G-0110P	23,8	13,7	11		13	-	11,1	10,8	10,5	10,2	9,9	9,3	8,6	7,9	7,1	6,3	4,3	-	
GKC6 200-135D-0150P	33	19,1	15		20,3	16,7	16,2	15,8	15,4	15	14,6	13,7	12,9	12,1	11,2	10,4	8,1	5,7	
GKC6 200-135A-0195P	40,2	23,2	19,5		23,2	19,6	19,2	18,7	18,3	17,9	17,5	16,7	15,9	15,1	14,3	13,5	11,3	8,9	

n ≈ 725 1/min

Model	400V	690V	P2	Q = Flow																	
				m³/h	0	108	126	144	162	180	216	252	288	324	360	450	540	630	720	810	900
						l/min	1800	2100	2400	2700	3000	3600	4200	4800	5400	6000	7500	9000	10500	12000	13500
A				H (m) = Total head																	
GKC8 250-163A-0210Z	44,1	25,2	21		19,7	16,9	16,6	16,4	16,2	15,9	15,4	14,9	14,4	13,9	13,4	12	10,6	9	7,1	5	2,5

n ≈ 950 1/min

Model	400V	690V	P2	Q = Flow																	
				m³/h	0	144	162	180	216	252	288	324	360	450	540	630	720	810	900	990	1080
						l/min	2400	2700	3000	3600	4200	4800	5400	6000	7500	9000	10500	12000	13500	15000	16500
A				H (m) = Total head																	
GKC6 250-163L-0250R	50,0	28,6	25		23,8	-	-	-	17,5	16,7	16,1	15,5	14,9	13,3	11,7	9,9	8,1	6,3	4,5	-	-
GKC6 250-163G-0340R	68,5	39,1	34		28,3	23,6	23,3	23	22,4	21,7	21	20,2	19,5	17,8	16	14,2	12,3	10,5	8,6	6,5	4
GKC6 250-163D-0420R	84,7	48,4	42		32	-	26,6	26,3	25,6	25	24,3	23,6	22,9	21,2	19,4	17,5	15,6	13,6	11,6	9,6	7,3
GKC6 250-163A-0510R	103	58,9	51		35,4	30,2	29,9	29,6	29	28,3	27,7	27	26,3	24,6	22,8	20,9	18,9	16,8	14,6	12,2	8,8
GKC6 250-163L-0250R-R	50,0	28,6	25		23,8	-	-	-	17,5	16,7	16,1	15,5	14,9	13,3	11,7	9,9	8,1	6,3	4,5	-	-
GKC6 250-163G-0340R-R	68,5	39,1	34		28,3	23,6	23,3	23	22,4	21,7	21	20,2	19,5	17,8	16	14,2	12,3	10,5	8,6	6,5	4
GKC6 250-163D-0420R-R	84,7	48,4	42		32	-	26,6	26,3	25,6	25	24,3	23,6	22,9	21,2	19,4	17,5	15,6	13,6	11,6	9,6	7,3
GKC6 250-163A-0510R-R	103	58,9	51		35,4	30,2	29,9	29,6	29	28,3	27,7	27	26,3	24,6	22,8	20,9	18,9	16,8	14,6	12,2	8,8

n ≈ 1450 1/min

Model	400V	690V	P2	Q = Flow												
				m³/h	0	324	360	450	540	630	720	810	900	990	1080	1188
						l/min	5400	6000	7500	9000	10500	12000	13500	15000	16500	18000
A				H (m) = Total head												
GKC4 250-163M-0820T	148	84,5	82		45,8	36,2	35,3	33	30,8	28,5	26,2	24	21,7	19,6	17,5	15
GKC4 250-163L-1000T	184	105	100		55,3	41,1	40	37,4	35	32,5	30,1	27,6	25,1	22,4	19,6	15,9
GKC4 250-163H-1000T	184	105	100		59,3	43,3	42,3	39,8	37,2	34,6	32,1	29,5	26,8	24	21	17,5
GKC4 250-163G-1200T	223	128	120		62,4	50,2	49,2	46,4	43,6	40,7	37,9	35	32,2	29,4	26,5	23,1
GKC4 250-163E-1450T	262	150	145		65,9	56,8	55,4	52,1	49,3	46,8	44,3	41,7	39	36,3	33,4	30,1
GKC4 250-163T-1450T	262	150	145		70,8	57	56	53,5	50,9	48,2	45,4	42,5	39,4	36,2	32,9	28,9
GKC4 250-163B-1450T	262	150	145		74,1	61	59,8	57,1	54,4	51,6	48,8	45,9	42,9	39,8	36,6	32,5
GKC4 250-163A-1800T	321	184	180		78,1	66,8	65,7	62,8	59,9	57,1	54,3	51,6	48,8	46	43	39,2
GKC4 250-163M-0820T-R	148	84,5	82		45,8	36,2	35,3	33	30,8	28,5	26,2	24	21,7	19,6	17,5	15
GKC4 250-163L-1000T-R	184	105	100		55,3	41,1	40	37,4	35	32,5	30,1	27,6	25,1	22,4	19,6	15,9
GKC4 250-163H-1000T-R	184	105	100		59,3	43,3	42,3	39,8	37,2	34,6	32,1	29,5	26,8	24	21	17,5
GKC4 250-163G-1200T-R	223	128	120		62,4	50,2	49,2	46,4	43,6	40,7	37,9	35	32,2	29,4	26,5	23,1
GKC4 250-163E-1450T-R	262	150	145		65,9	56,8	55,4	52,1	49,3	46,8	44,3	41,7	39	36,3	33,4	30,1
GKC4 250-163T-1450T-R	262	150	145		70,8	57	56	53,5	50,9	48,2	45,4	42,5	39,4	36,2	32,9	28,9
GKC4 250-163B-1450T-R	262	150	145		74,1	61	59,8	57,1	54,4	51,6	48,8	45,9	42,9	39,8	36,6	32,5
GKC4 250-163A-1800T-R	321	184	180		78,1	66,8	65,7	62,8	59,9	57,1	54,3	51,6	48,8	46	43	39,2

Characteristic curves

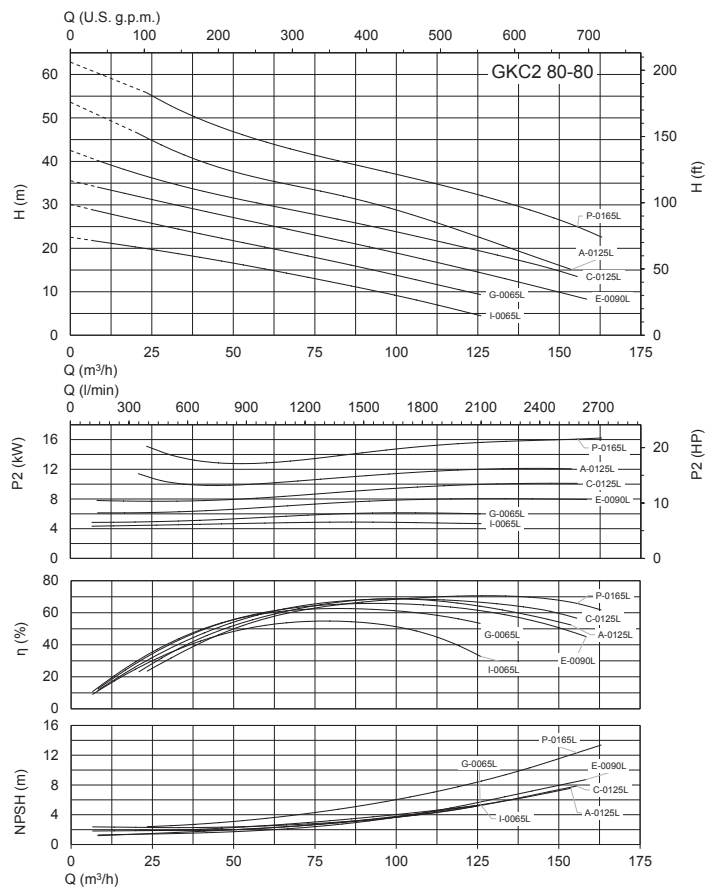
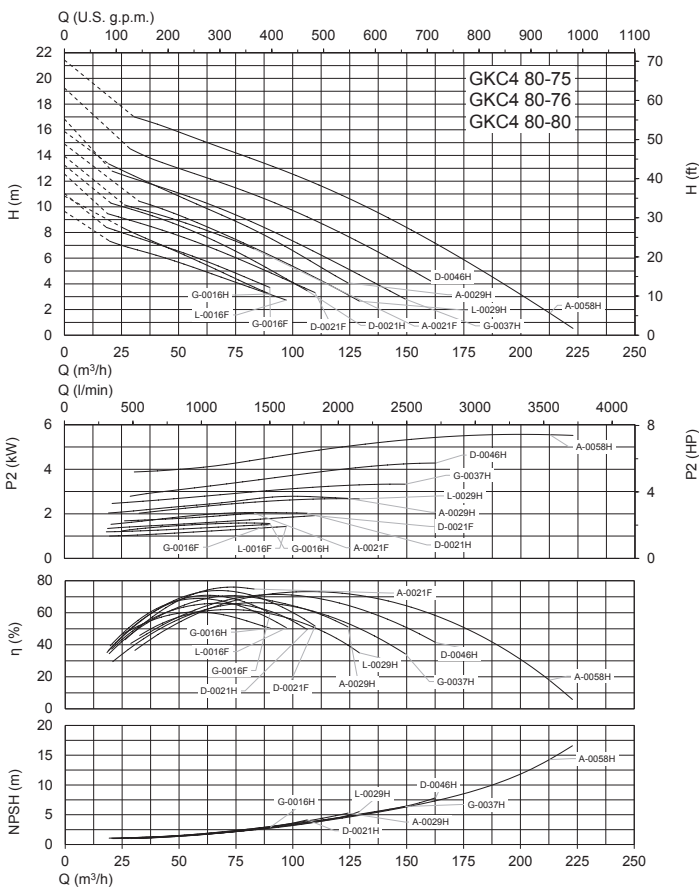
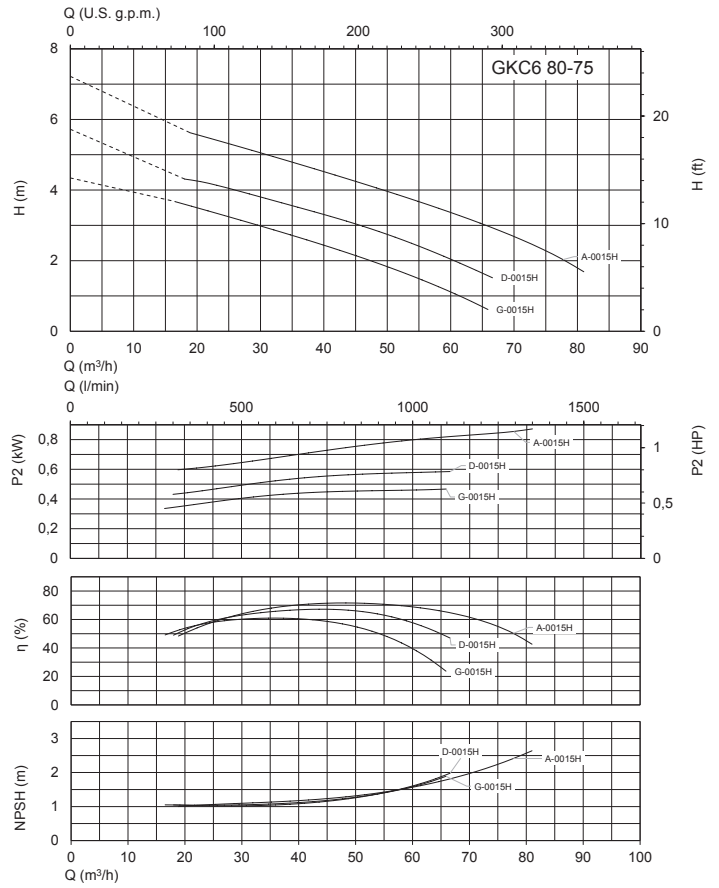
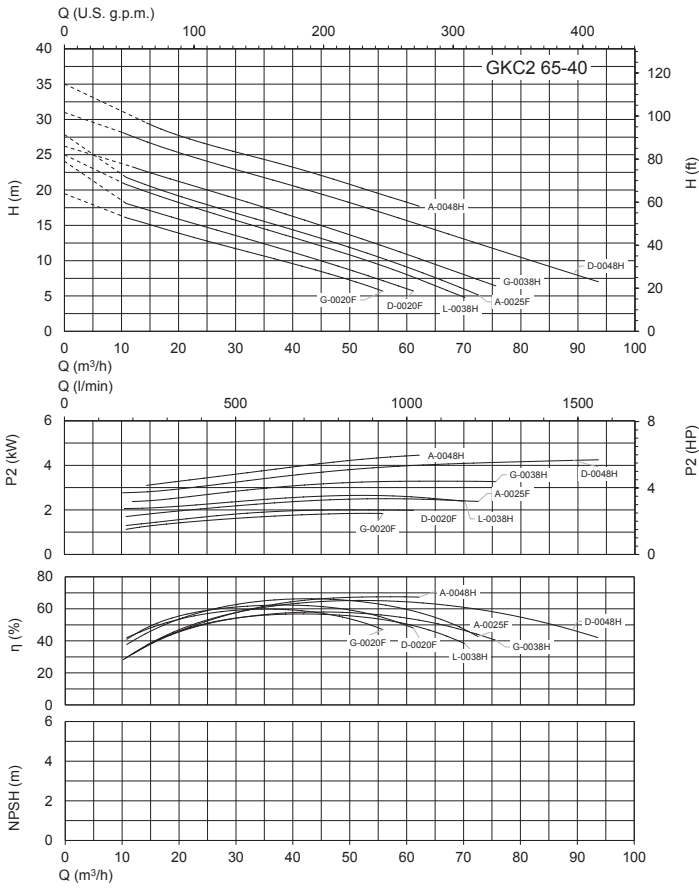

Characteristic curves

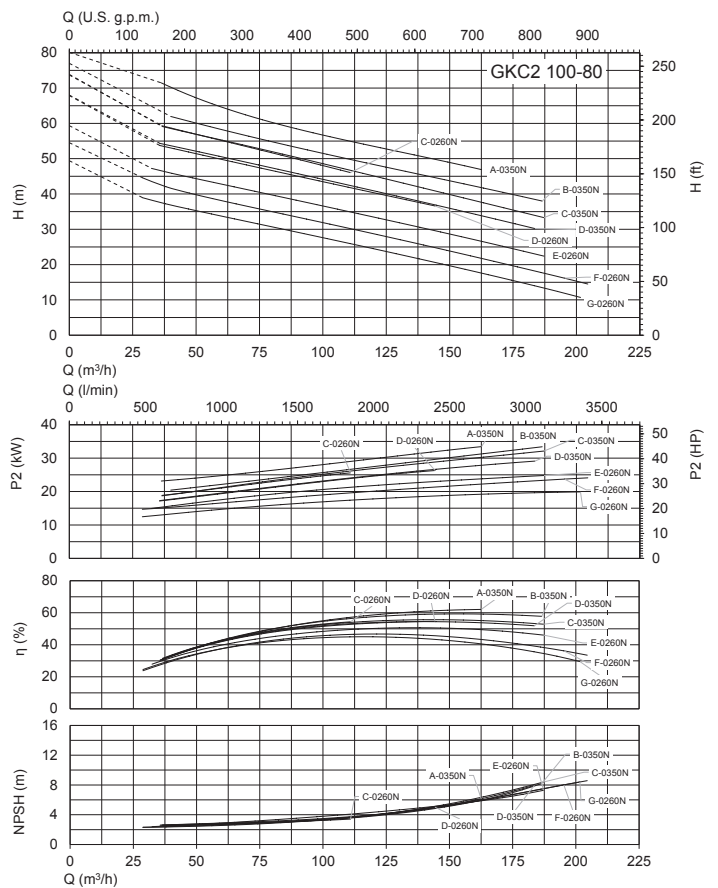
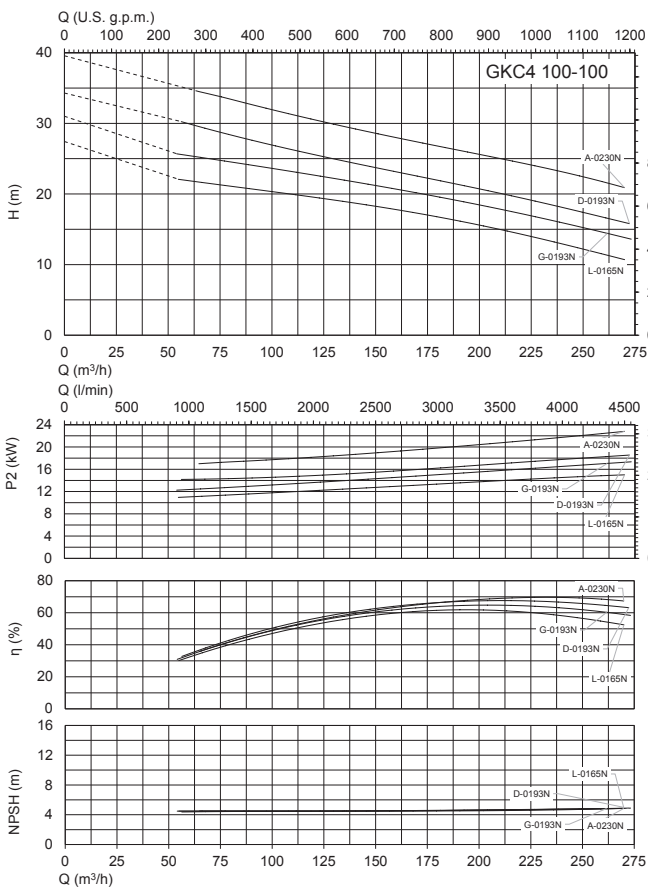
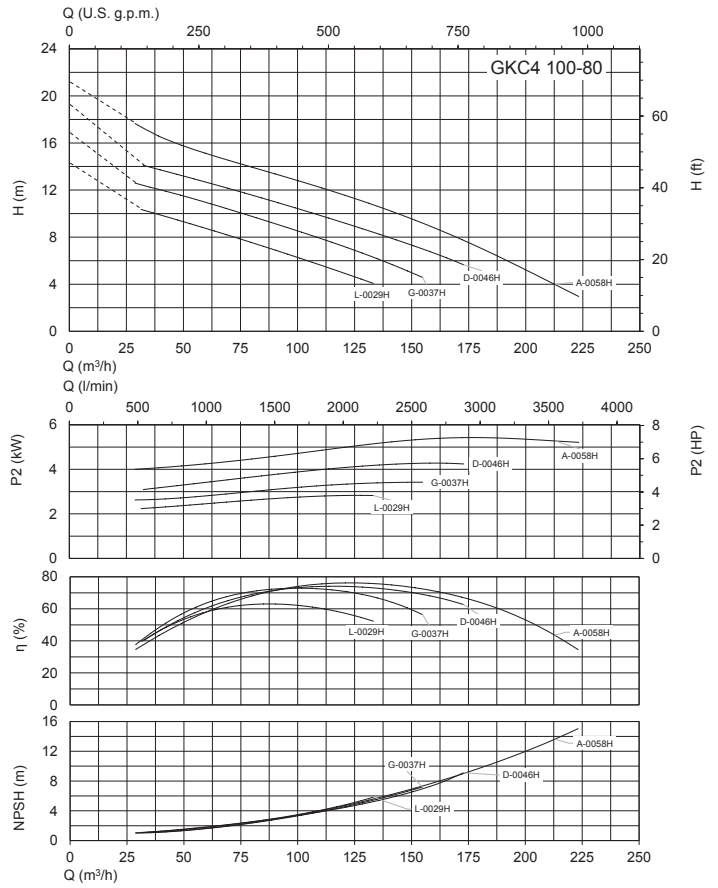
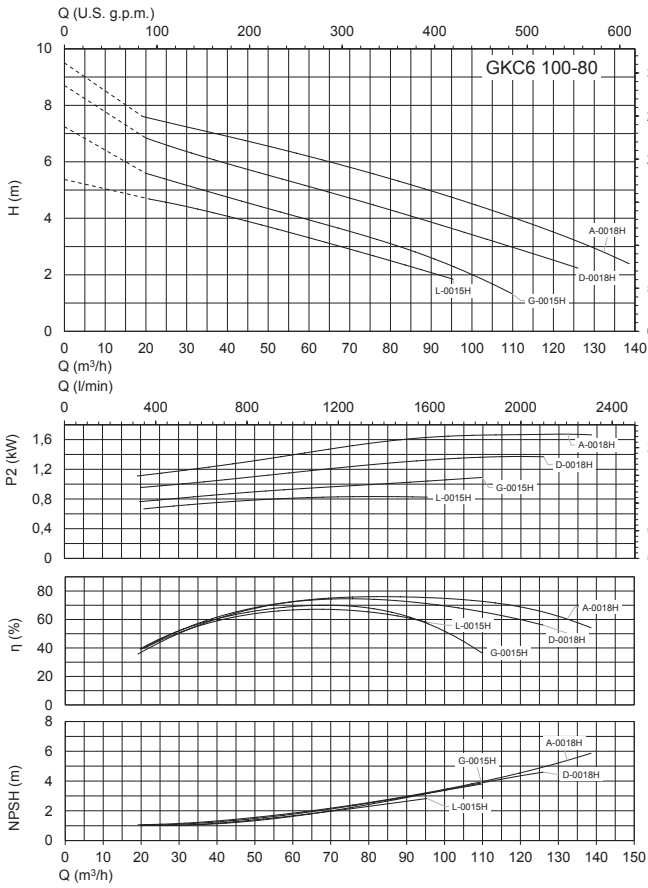

Characteristic curves

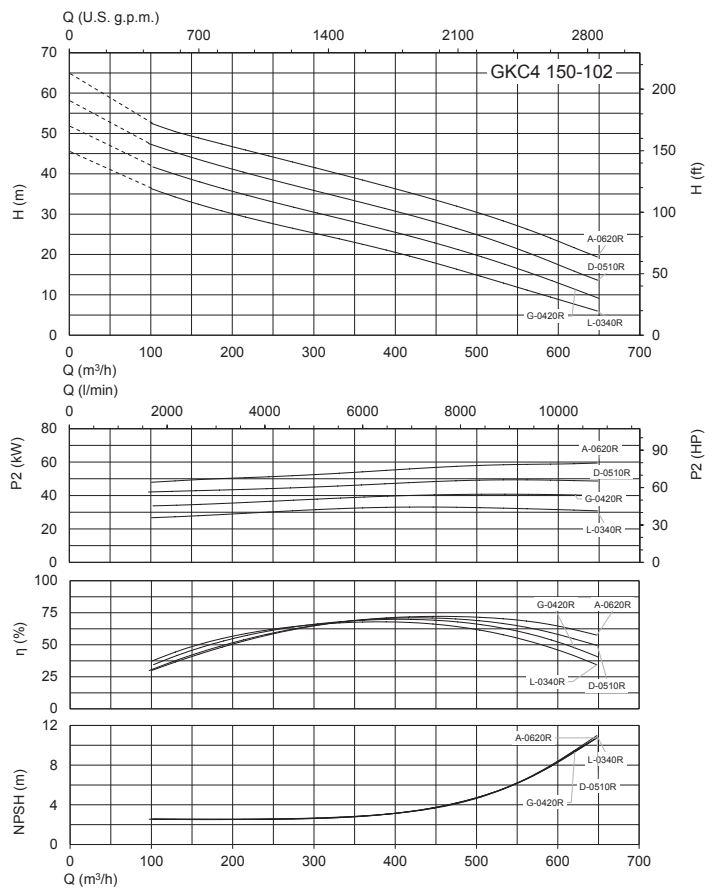
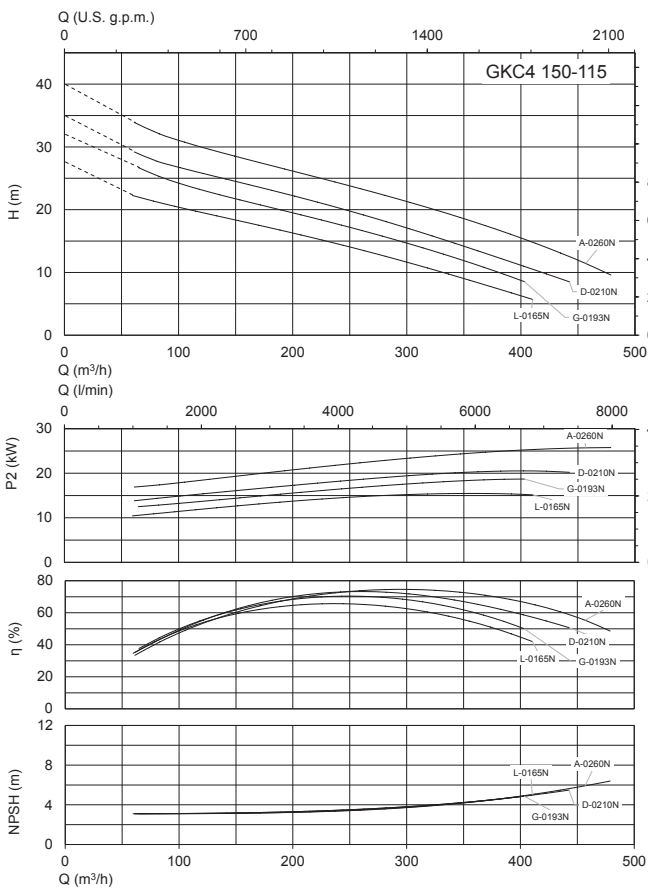
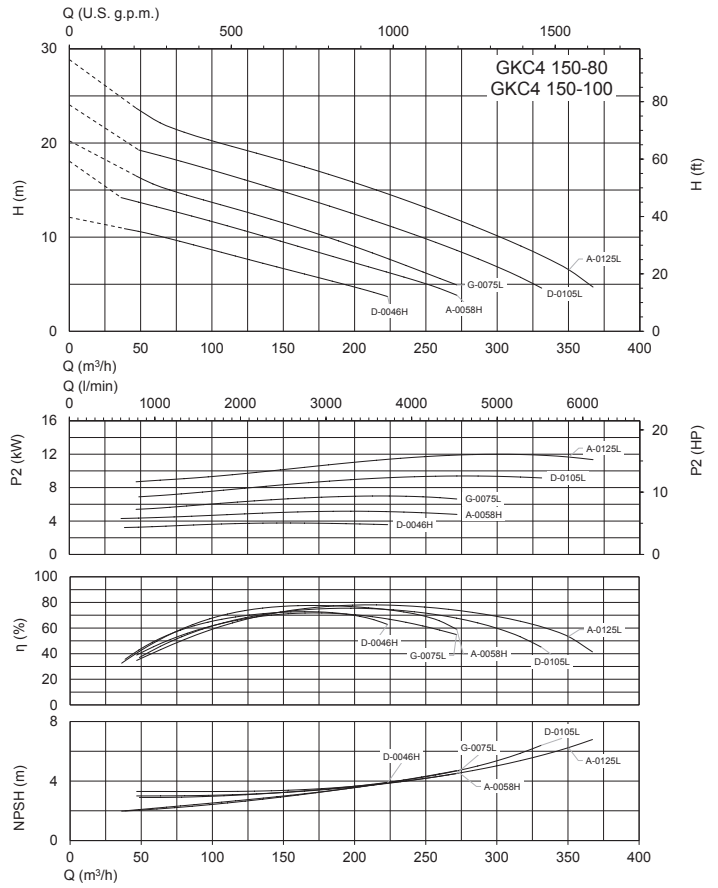
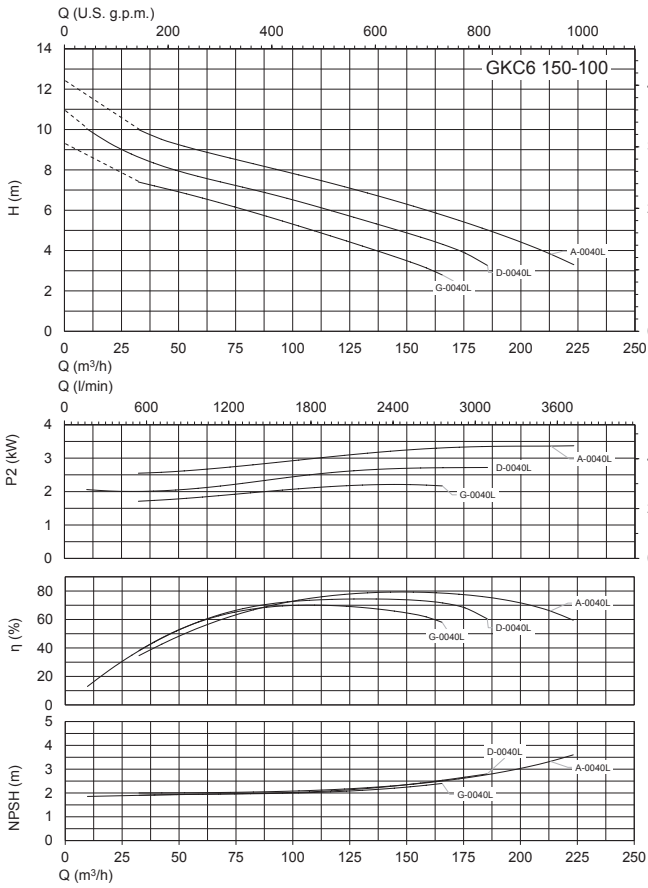

Characteristic curves

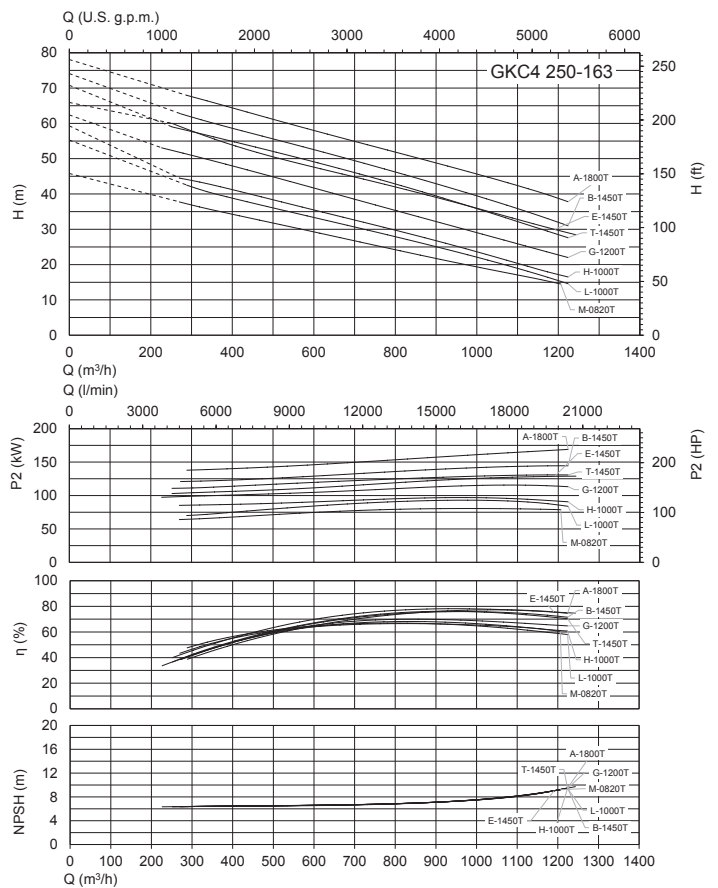
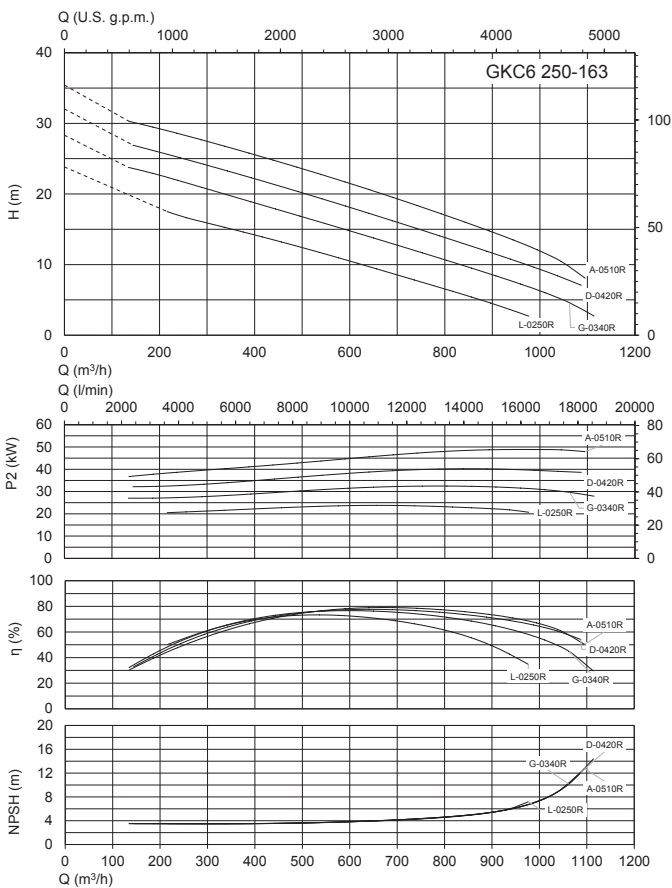
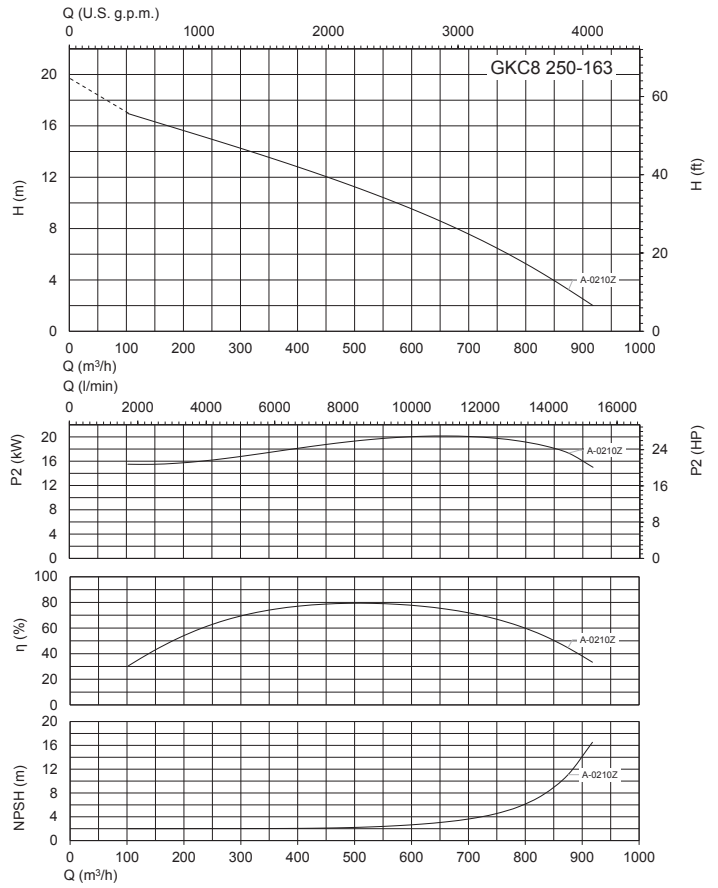
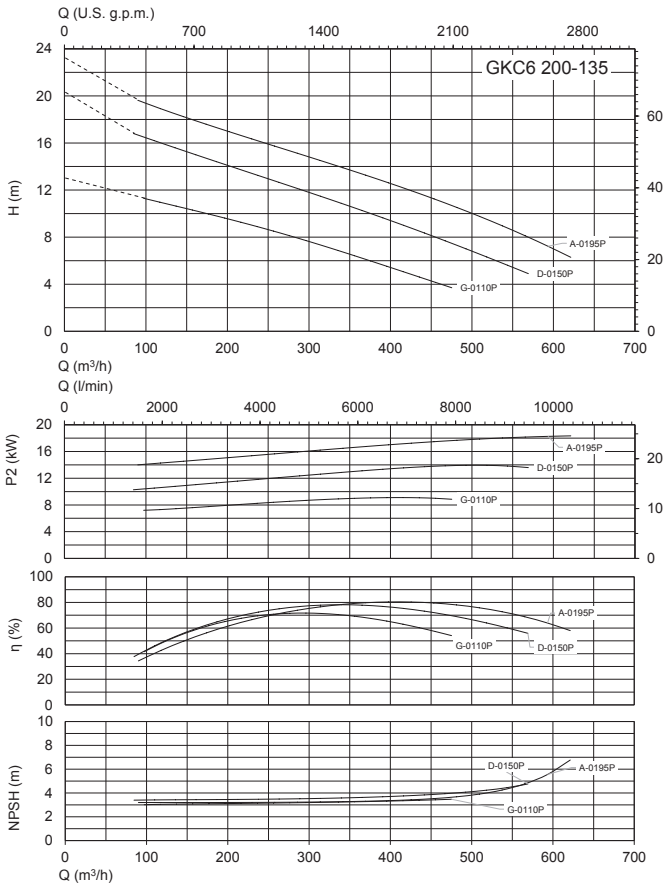

Dimensions and weights

Duck foot coupling

SAK

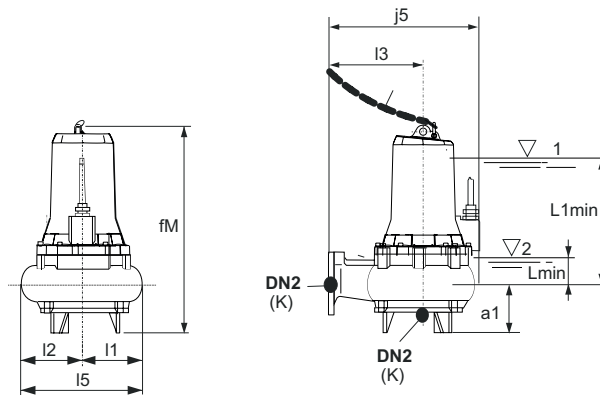
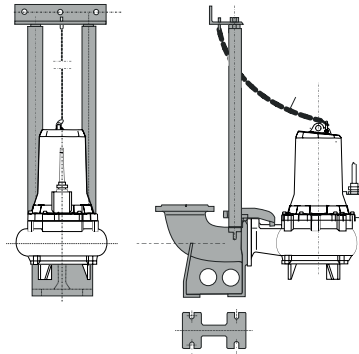

TYPE	mm											Kg Weight
	DN2	a1	fM	j5	K	l1	l2	l5	l5	L1min	Lmin	
GKC2 65-40G-0020F	65	140	561.6	373	16	148	148	225	296	255	90	61
GKC2 65-40D-0020F	65	140	561.6	373	16	148	148	225	296	255	90	60
GKC2 65-40A-0025F	65	140	561.6	373	16	148	148	225	296	255	90	58

L1min = Minimum submergence depth for motor without casing with continuous duty S1 (NPSHR permitting)

Lmin = Minimum submergence depth for motor without casing with intermittent duty S3 (NPSHR permitting)

Dimensions and weights

Duck foot coupling

SAK

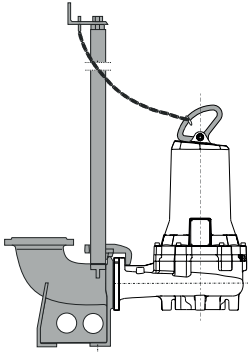

Submersible pump rest

APK

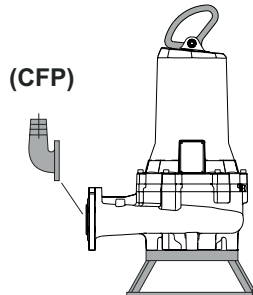

Dry chamber pump rest

APCK

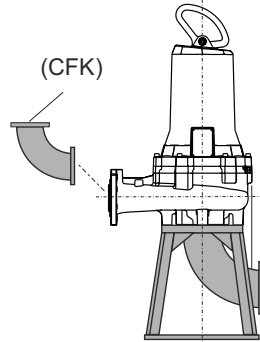

Dry chamber pump support

SOK

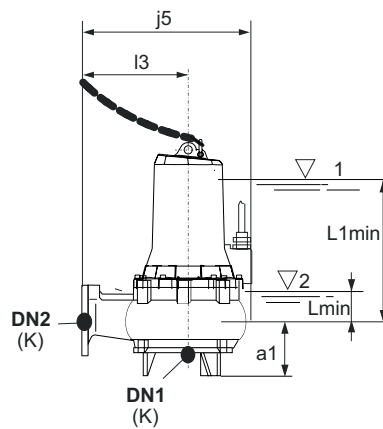
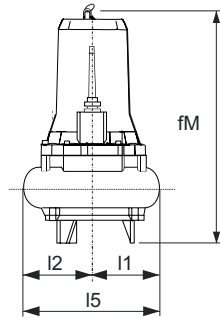
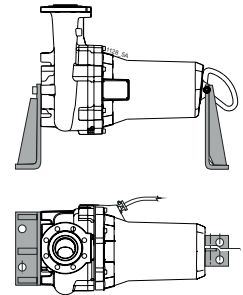

TYPE	mm							
	DN1	DN2	a1	fM	j5	l1	l2	l5
GKC2 65-40A-0048H	65	65	805	601.7	390	204.5	145	245
GKC2 65-40D-0048H	65	65	805	601.7	390	204.5	145	245
GKC2 65-40G-0038H	65	65	805	601.7	390	204.5	145	245
GKC2 65-40L-0038H	65	65	805	601.7	390	204.5	145	245

L1min = Minimum submergence depth for motor without casing with continuous duty S1 (NPSHR permitting)

Lmin = Minimum submergence depth for motor without casing with intermittent duty S3 (NPSHR permitting)

Dimensions and weights

Duck foot coupling

SAK

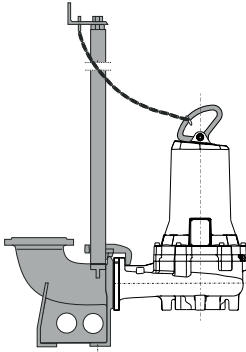

Submersible pump rest

APK

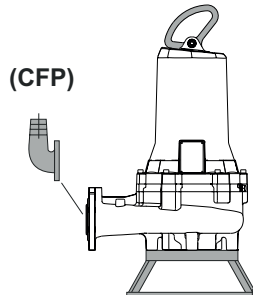

Dry chamber pump rest

APCK

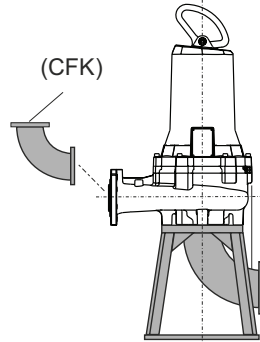

Dry chamber pump support

SOK

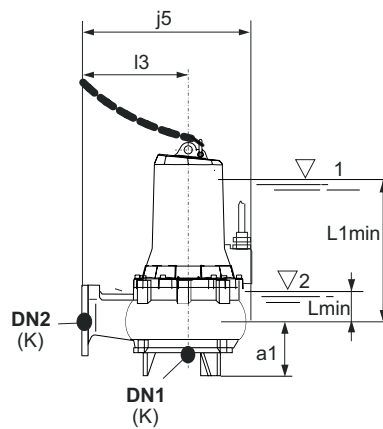
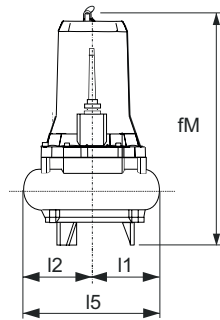
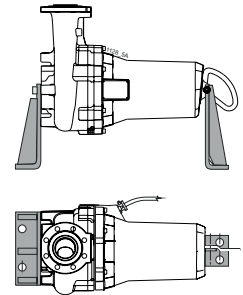

TYPE	mm												Kg Peso
	DN1	DN2	a1	fM	j5	K	l1	l2	l3	l5	L1min	Lmin	
GKC6 80-75G-0015H	80	80	121	647.3	407	16	204.5	176	245	380.5	297	75	87.2
GKC6 80-75D-0015H	80	80	121	647.3	407	16	204.5	176	245	380.5	297	75	87.1
GKC6 80-75A-0015H	80	80	121	647.3	407	16	204.5	176	245	380.5	297	75	84.9
GKC4 80-75G-0016H	80	80	121	647.3	407	16	204.5	176	245	380.5	297	75	91.3
GKC4 80-75D-0021H	80	80	118	650.3	435	16	204.5	176	255	380.5	370	80	95.6
GKC4 80-75A-0029H	80	80	121	647.3	407	16	204.5	176	245	380.5	297	75	92
GKC4 80-80G-0037H	100	80	120.5	716.4	407	16	221	176	245	397	370	80	117.6
GKC4 80-80L-0029H	100	80	120.5	647.3	407	16	204.5	176	245	380.5	322	80	95
GKC4 80-80D-0046H	100	80	120.5	716.4	407	16	221	176	245	397	370	80	108
GKC4 80-80A-0058H	100	80	120.5	716.4	407	16	221	176	245	397	370	80	120
GKC2 80-80P-0165L	80	80	95	765.4	498	16	236.5	180	325	416.5	438	87	172.2
GKC2 80-80I-0065L	80	80	95	763	498	16	225.5	180	325	405.5	438	87	134
GKC2 80-80G-0065L	80	80	95	763	498	16	225.5	180	325	405.5	438	87	137
GKC2 80-80E-0090L	80	80	95	763	498	16	225.5	180	325	405.5	438	87	142.5
GKC2 80-80C-0125L	80	80	95	763	498	16	225.5	180	325	405.5	438	87	148.1
GKC2 80-80A-0125L	80	80	95	763	498	16	225.5	180	325	405.5	438	87	150

L1min = Minimum submergence depth for motor without casing with continuous duty S1 (NPSHR permitting)

Lmin = Minimum submergence depth for motor without casing with intermittent duty S3 (NPSHR permitting)

Dimensions and weights

Duck foot coupling

SAK

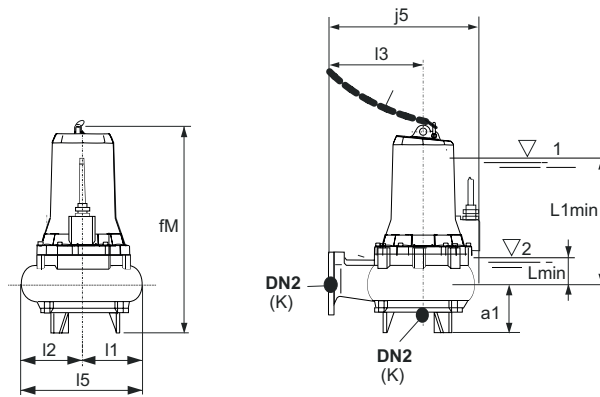
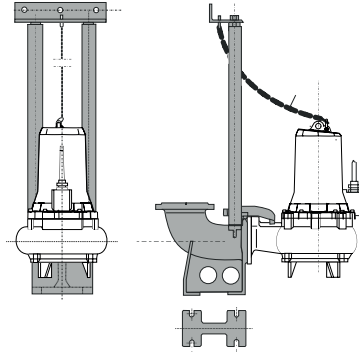

TYPE	mm						
	DN2	a1	fM	j5	l1	l2	l3
GKC4 80-76A-0021F	80	180	622.6	393	144	173	235
GKC4 80-76D-0021F	80	180	622.6	393	144	173	235
GKC4 80-76G-0016F	80	180	622.6	393	144	173	235
GKC4 80-76L-0016F	80	180	622.6	393	144	173	235

L1min = Minimum submergence depth for motor without casing with continuous duty S1 (NPSHR permitting)
 Lmin = Minimum submergence depth for motor without casing with intermittent duty S3 (NPSHR permitting)

Dimensions and weights

Duck foot coupling

SAK

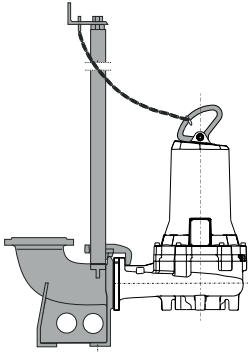

Submersible pump rest

APK

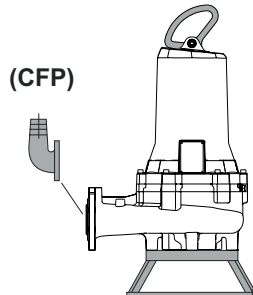

Dry chamber pump rest

APCK

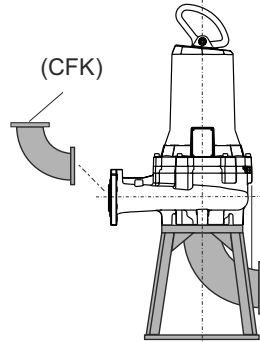

Dry chamber pump support

SOK

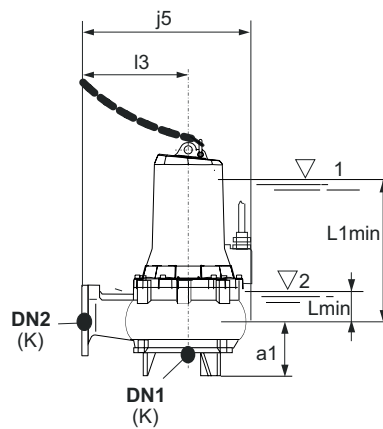
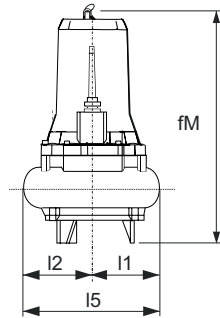
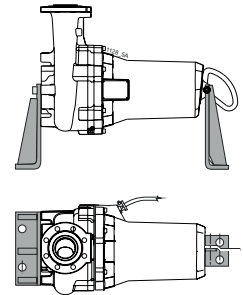

TYPE	mm												Kg Weight
	DN1	DN2	a1	fM	j5	K	l1	l2	l5	l5	L1min	Lmin	
GKC6 100-80L-0015H	100	100	118	650.3	435	16	204.5	198	255	402.5	302	82	94.7
GKC6 100-80G-0015H	100	100	118	650.3	435	16	204.5	198	255	402.5	302	82	94.7
GKC6 100-80D-0018H	100	100	118	719.4	435	16	221	198	255	419	337	82	116
GKC6 100-80A-0018H	100	100	118	719.4	435	16	221	198	255	419	337	82	116
GKC4 100-80L-0029H	100	100	118	650.3	435	16	204.5	198	255	402.5	302	82	103.2
GKC4 100-80G-0037H	100	100	118	719.4	435	16	221	198	255	419	337	82	118
GKC4 100-80D-0046H	100	100	118	719.4	435	16	221	198	255	419	337	82	113
GKC4 100-80A-0058H	100	100	118	719.4	435	16	221	198	255	419	337	82	126.6

L1min = Minimum submergence depth for motor without casing with continuous duty S1 (NPSHR permitting)

Lmin = Minimum submergence depth for motor without casing with intermittent duty S3 (NPSHR permitting)

Dimensions and weights

Duck foot coupling

SAK

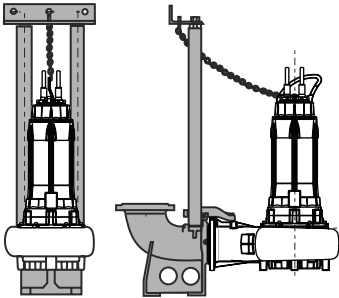

Submersible pump rest

APK

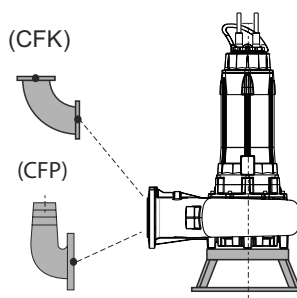

Dry chamber pump rest

APCK

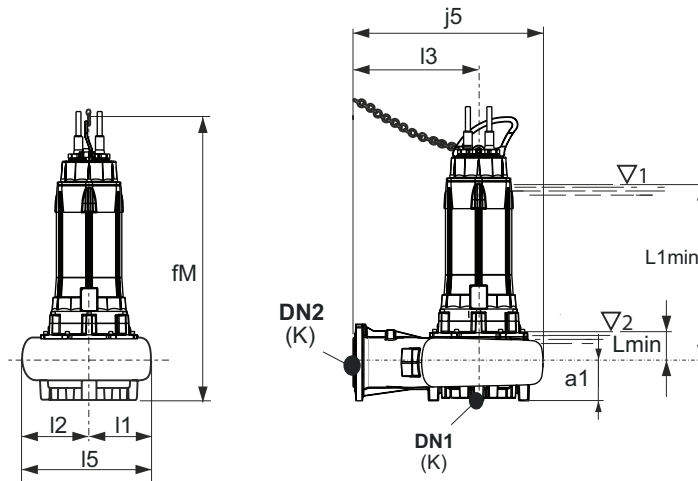
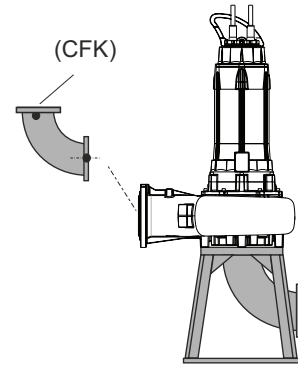

TYPE	mm												Kg Weight
	DN1	DN2	a1	fM	j5	K	l1	l2	l5	l5	L1min	Lmin	
GKC4 100-100L-0165N	150	100	160	1240	551	16	224	262	308	486	795	174	350.1
GKC4 100-100G-0193N	150	100	160	1240	551	16	224	262	308	486	795	174	371.9
GKC4 100-100D-0193N	150	100	160	1240	551	16	224	262	308	486	795	174	372.8
GKC4 100-100A-0230N	150	100	160	1240	551	16	224	262	308	486	795	174	380.7
GKC2 100-80C-0260N	100	100	110	1183	553	16	200	200	335	400	788	167	343.9
GKC2 100-80D-0260N	100	100	110	1183	553	16	200	200	335	400	788	167	343.7
GKC2 100-80G-0260N	100	100	110	1183	553	16	200	200	335	400	788	167	342.3
GKC2 100-80F-0260N	100	100	110	1183	553	16	200	200	335	400	788	167	342.4
GKC2 100-80E-0260N	100	100	110	1183	553	16	200	200	335	400	788	167	342.9
GKC2 100-80C-0350N	100	100	110	1183	553	16	200	200	335	400	788	167	367.1
GKC2 100-80D-0350N	100	100	110	1183	553	16	200	200	335	400	788	167	366.9
GKC2 100-80B-0350N	100	100	110	1183	553	16	200	200	335	400	788	167	367.4
GKC2 100-80A-0350N	100	100	110	1183	553	16	200	200	335	400	788	167	368.1

L1min = Minimum submergence depth for motor without casing with continuous duty S1 (NPSHR permitting)

Lmin = Minimum submergence depth for motor without casing with intermittent duty S3 (NPSHR permitting)

Dimensions and weights

Duck foot coupling

SAK

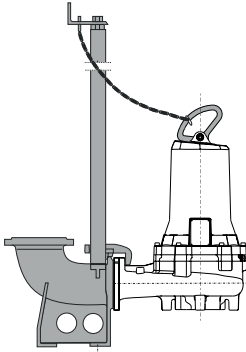

Submersible pump rest

APK

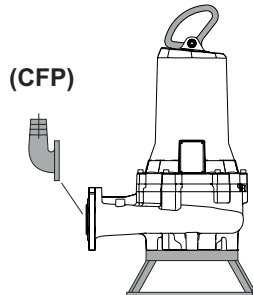

Dry chamber pump rest

APCK

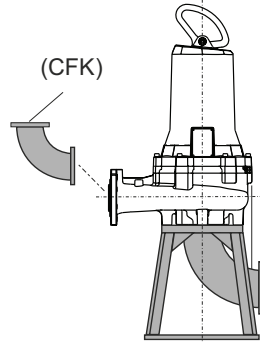

Dry chamber pump support

SOK

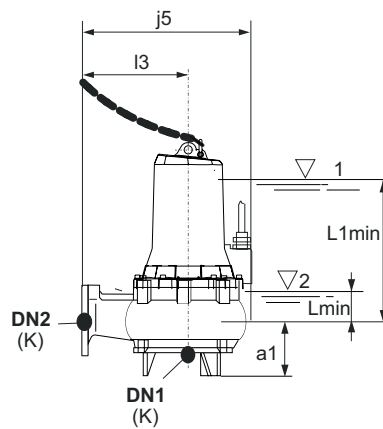
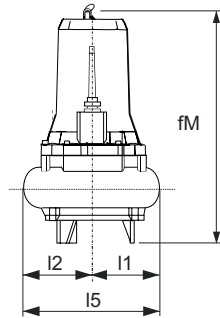
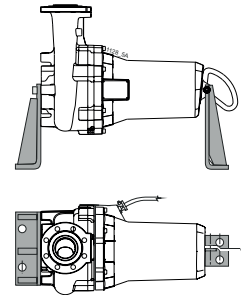

TYPE	mm												Kg Weight
	DN1	DN2	a1	fM	j5	K	l1	l2	l5	l5	L1min	Lmin	
GKC6 150-100G-0040L	150	150	138	808	532	16	227	241	305	468	440	89	168.5
GKC6 150-100D-0040L	150	150	138	808	532	16	227	241	305	468	440	89	168
GKC6 150-100A-0040L	150	150	138	808	532	16	227	241	305	468	440	89	167.8
GKC4 150-80D-0046H	150	150	138	752.9	567	16	227	238.5	340	465.5	350	95	155
GKC4 150-80A-0058H	150	150	138	752.9	567	16	227	238.5	340	465.5	350	95	164.4
GKC4 150-100G-0075L	150	150	138	808	532	16	227	241	305	468	440	89	177
GKC4 150-100D-0105L	150	150	138	810.4	532	16	236	241	305	477	440	89	199.7
GKC4 150-100A-0125L	150	150	138	810.4	532	16	236.5	241	305	477.5	440	89	199.5

L1min = Minimum submergence depth for motor without casing with continuous duty S1 (NPSHR permitting)

Lmin = Minimum submergence depth for motor without casing with intermittent duty S3 (NPSHR permitting)

Dimensions and weights

Duck foot coupling

SAK

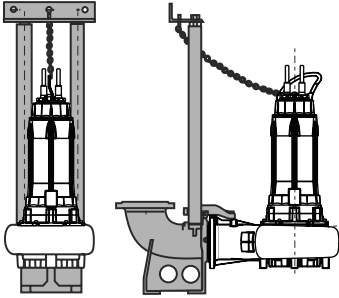

Submersible pump rest

APK

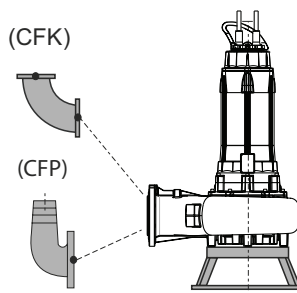

Dry chamber pump rest

APCK

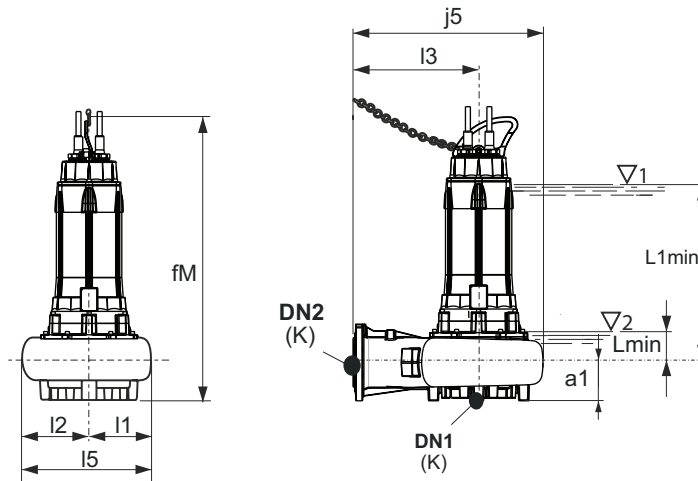
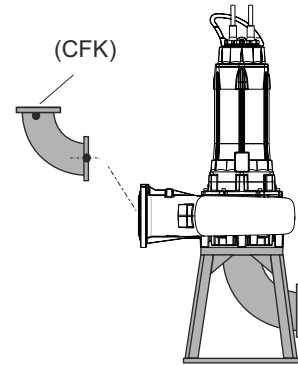

TYPE	mm												Kg Weight
	DN1	DN2	a1	fM	j5	K	I1	I2	I5	I5	L1min	Lmin	
GKC4 150-115L-0165N	150	150	160	1240	658	16	229	278	405	507	795	174	358
GKC4 150-115G-0193N	150	150	160	1240	658	16	229	278	405	507	795	174	379.9
GKC4 150-115D-0210N	150	150	160	1240	658	16	229	278	405	507	795	174	380
GKC4 150-115A-0260N	150	150	160	1240	658	16	229	278	405	507	795	174	388.7

L1min = Minimum submergence depth for motor without casing with continuous duty S1 (NPSHR permitting)

Lmin = Minimum submergence depth for motor without casing with intermittent duty S3 (NPSHR permitting)

Dimensions and weights

Duck foot coupling

SAK

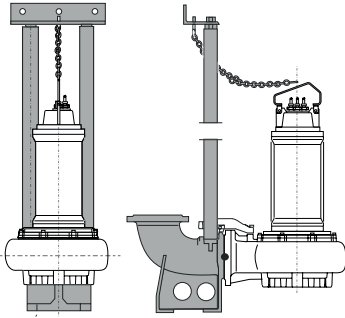

Submersible pump rest

APK

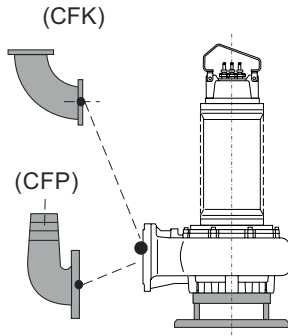

Dry chamber pump rest

APCK

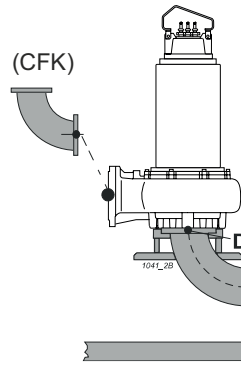

Dry chamber pump support

SOK

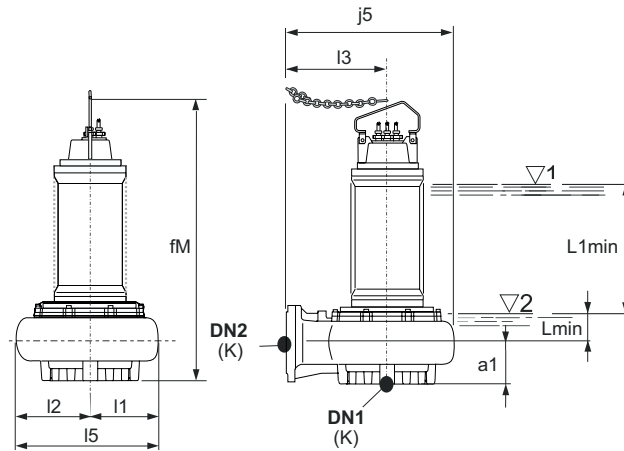
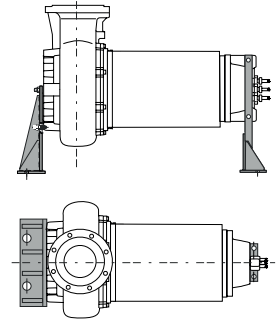

TYPE	mm												Kg Weight
	DN1	DN2	a1	fM	j5	K	l1	l2	l5	l5	L1min	Lmin	
GKC4 150-102L-0340R	150	150	195	1559.5	825	16	305	365	500	670	900	155	567
GKC4 150-102G-0420R	150	150	195	1559.5	825	16	305	365	500	670	900	155	677
GKC4 150-102D-0510R	150	150	195	1559.5	825	16	305	365	500	670	900	155	607
GKC4 150-102A-0620R	150	150	195	1581.5	825	16	305	365	500	670	900	155	812
GKC4 150-102L-0340R-R	150	150	195	1559.5	825	16	305	365	500	670	900	155	582
GKC4 150-102G-0420R-R	150	150	195	1559.5	825	16	305	365	500	670	900	155	692
GKC4 150-102D-0510R-R	150	150	195	1559.5	825	16	305	365	500	670	900	155	622
GKC4 150-102A-0620R-R	150	150	195	1581.5	825	16	305	365	500	670	900	155	832

L1min = Minimum submergence depth for motor without casing with continuous duty S1 (NPSHR permitting)

Lmin = Minimum submergence depth for motor without casing with intermittent duty S3 (NPSHR permitting)

Dimensions and weights

Duck foot coupling

SAK

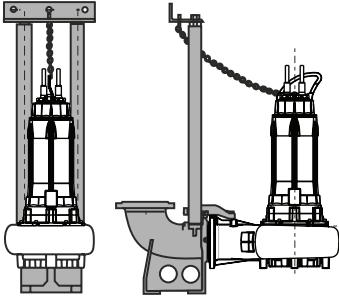

Submersible pump rest

APK

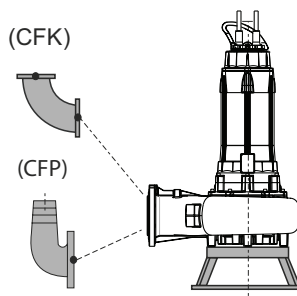

Dry chamber pump rest

APCK

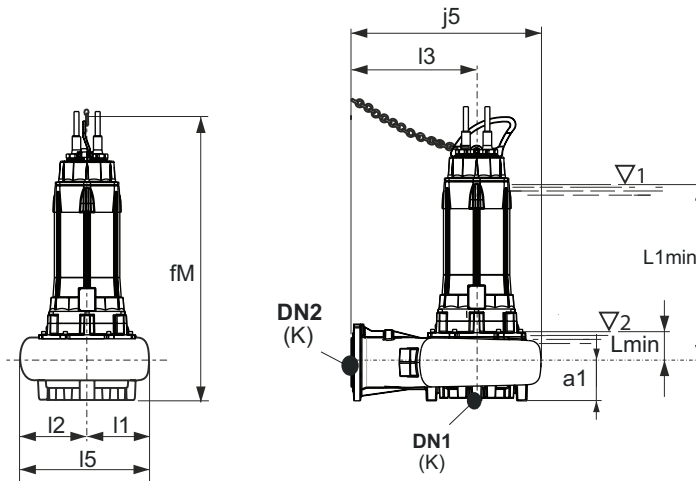
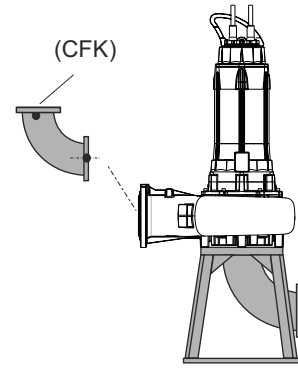

TYPE	mm												Kg Weight
	DN1	DN2	a1	fM	j5	K	I1	I2	I5	I5	L1min	Lmin	
GKC6 200-135G-0110P	200	200	185	1280	765	10	277	345	455	622	810	189	423.3
GKC6 200-135D-0150P	200	200	185	1280	765	10	277	345	455	622	810	189	450.2
GKC6 200-135A-0195P	200	200	185	1280	765	10	277	345	455	622	810	189	497.5

L1min = Minimum submergence depth for motor without casing with continuous duty S1 (NPSHR permitting)

Lmin = Minimum submergence depth for motor without casing with intermittent duty S3 (NPSHR permitting)

Dimensions and weights

Duck foot coupling

SAK

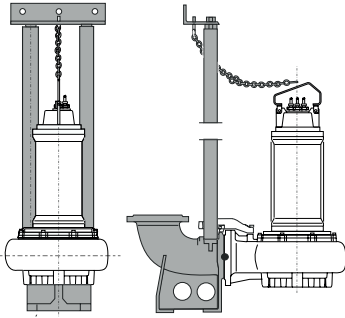

Submersible pump rest

APK

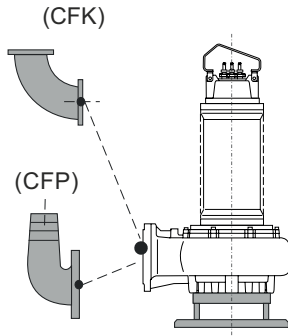

Dry chamber pump rest

APCK

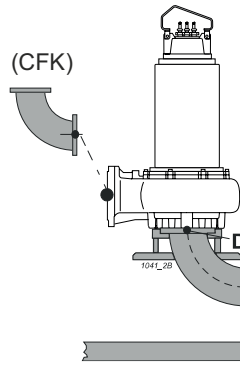

Dry chamber pump support

SOK

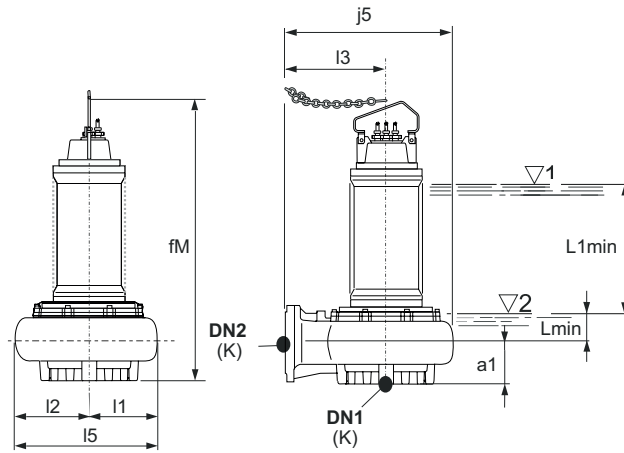
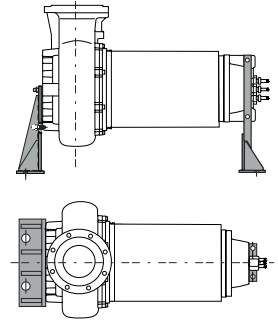

HL minimum level of submersibility

TYPE	mm												Kg Weight
	DN1	DN2	a1	fM	j5	K	l1	l2	l5	l5	L1min	Lmin	
GKC8 250-163A-0210Z	250	250	220	1612.5	935	10	330	405	570	735	930	185	653
GKC8 250-163A-0210Z-R	250	250	220	1612.5	935	10	330	405	570	735	930	185	668

L1min = Minimum submergence depth for motor without casing with continuous duty S1 (NPSHR permitting)

Lmin = Minimum submergence depth for motor without casing with intermittent duty S3 (NPSHR permitting)

Dimensions and weights

Duck foot coupling

SAK

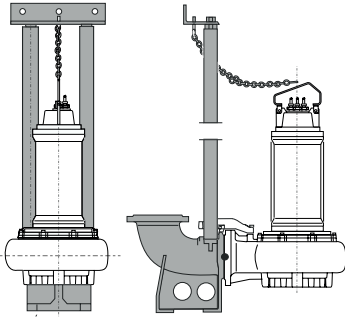

Submersible pump rest

APK

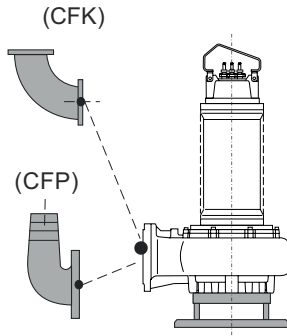

Dry chamber pump rest

APCK

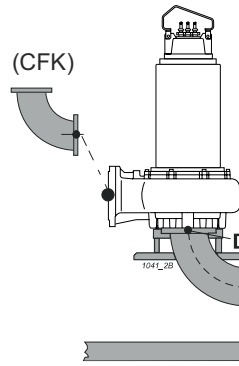

Dry chamber pump support

SOK

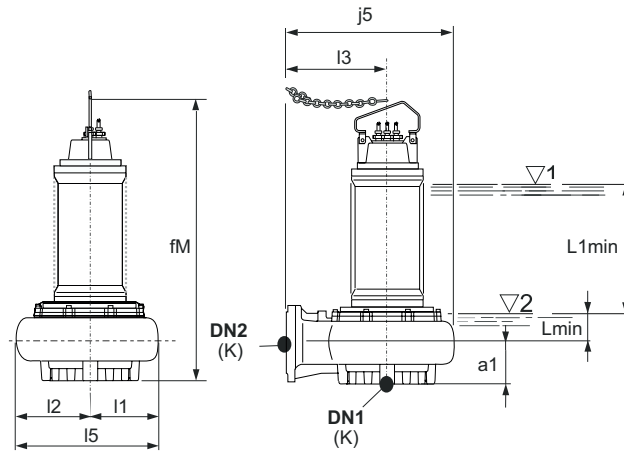
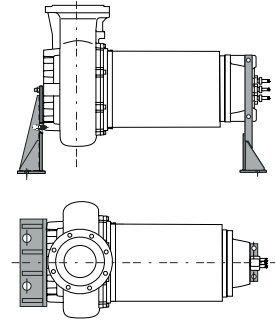

TYPE	mm												Kg Weight
	DN1	DN2	a1	fM	j5	K	l1	l2	l5	l5	l1min	lmin	
GKC6 250-163L-0250R	250	250	220	1612.5	935	10	330	405	570	735	930	185	717
GKC6 250-163G-0340R	250	250	220	1612.5	935	10	330	405	570	735	930	185	653
GKC6 250-163D-0420R	250	250	220	1612.5	935	10	330	405	570	735	930	185	744
GKC6 250-163A-0510R	250	250	220	1644.5	935	10	330	405	570	735	930	185	885
GKC6 250-163L-0250R-R	250	250	220	1612.5	935	10	330	405	570	735	930	185	732
GKC6 250-163G-0340R-R	250	250	220	1612.5	935	10	330	405	570	735	930	185	668
GKC6 250-163D-0420R-R	250	250	220	1612.5	935	10	330	405	570	735	930	185	688
GKC6 250-163A-0510R-R	250	250	220	1644.5	935	10	330	405	570	735	930	185	1023

L1min = Minimum submergence depth for motor without casing with continuous duty S1 (NPSHR permitting)

Lmin = Minimum submergence depth for motor without casing with intermittent duty S3 (NPSHR permitting)

Dimensions and weights

Duck foot coupling

SAK

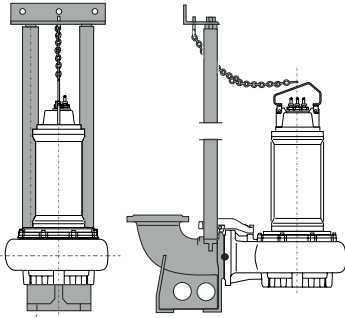

Submersible pump rest

APK

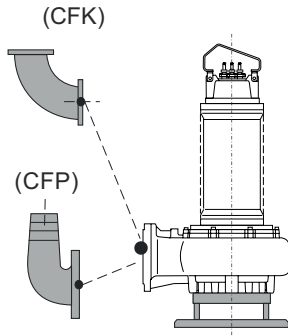

Dry chamber pump rest

APCK

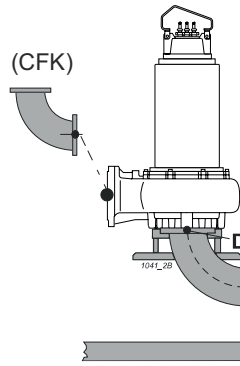

Dry chamber pump support

SOK

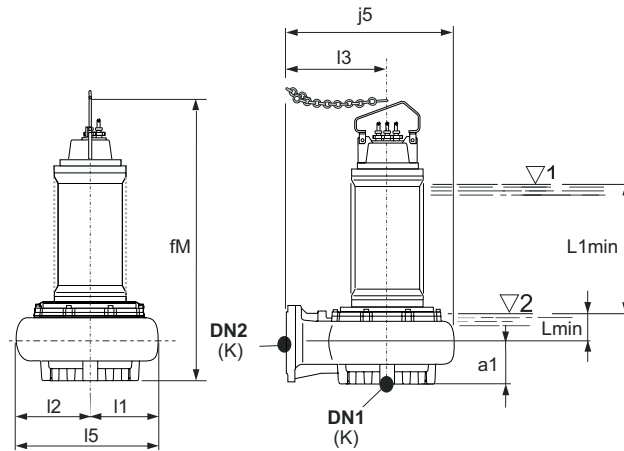
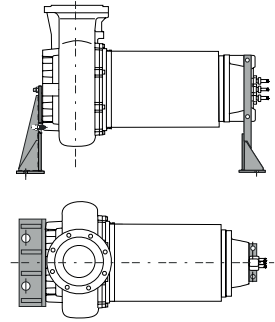

TYPE	mm												Kg Weight
	DN1	DN2	a1	fM	j5	K	l1	l2	l5	l5	L1min	Lmin	
GKC4 250-163M-0820T	250	250	220	1666.5	935	10	330	405	570	735	1023	185	1077
GKC4 250-163L-1000T	250	250	220	1880	935	10	330	405	570	735	1140	185	1078
GKC4 250-163H-1000T	250	250	220	1880	935	10	330	405	570	735	1140	185	1355
GKC4 250-163G-1200T	250	250	220	1880	935	10	330	405	570	735	1140	185	1416
GKC4 250-163E-1450T	250	250	220	1880	935	10	330	405	570	735	1140	185	1468
GKC4 250-163T-1450T	250	250	220	1880	935	10	330	405	570	735	1140	185	1469
GKC4 250-163B-1450T	250	250	220	1880	935	10	330	405	570	735	1140	185	1880
GKC4 250-163A-1800T	250	250	220	2116	935	10	330	405	570	735	1350	185	1872
GKC4 250-163M-0820T-R	250	250	220	1666.5	935	10	330	405	570	735	1023	185	1098
GKC4 250-163L-1000T-R	250	250	220	1880	935	10	330	405	570	735	1140	185	1311
GKC4 250-163H-1000T-R	250	250	220	1880	935	10	330	405	570	735	1140	185	1588
GKC4 250-163G-1200T-R	250	250	220	1880	935	10	330	405	570	735	1140	185	1650
GKC4 250-163E-1450T-R	250	250	220	1880	935	10	330	405	570	735	1140	185	1702
GKC4 250-163T-1450T-R	250	250	220	1880	935	10	330	405	570	735	1140	185	1703
GKC4 250-163B-1450T-R	250	250	220	1880	935	10	330	405	570	735	1140	185	1705
GKC4 250-163A-1800T-R	250	250	220	2116	935	10	330	405	570	735	1350	185	2200

L1min = Minimum submergence depth for motor without casing with continuous duty S1 (NPSHR permitting)

Lmin = Minimum submergence depth for motor without casing with intermittent duty S3 (NPSHR permitting)

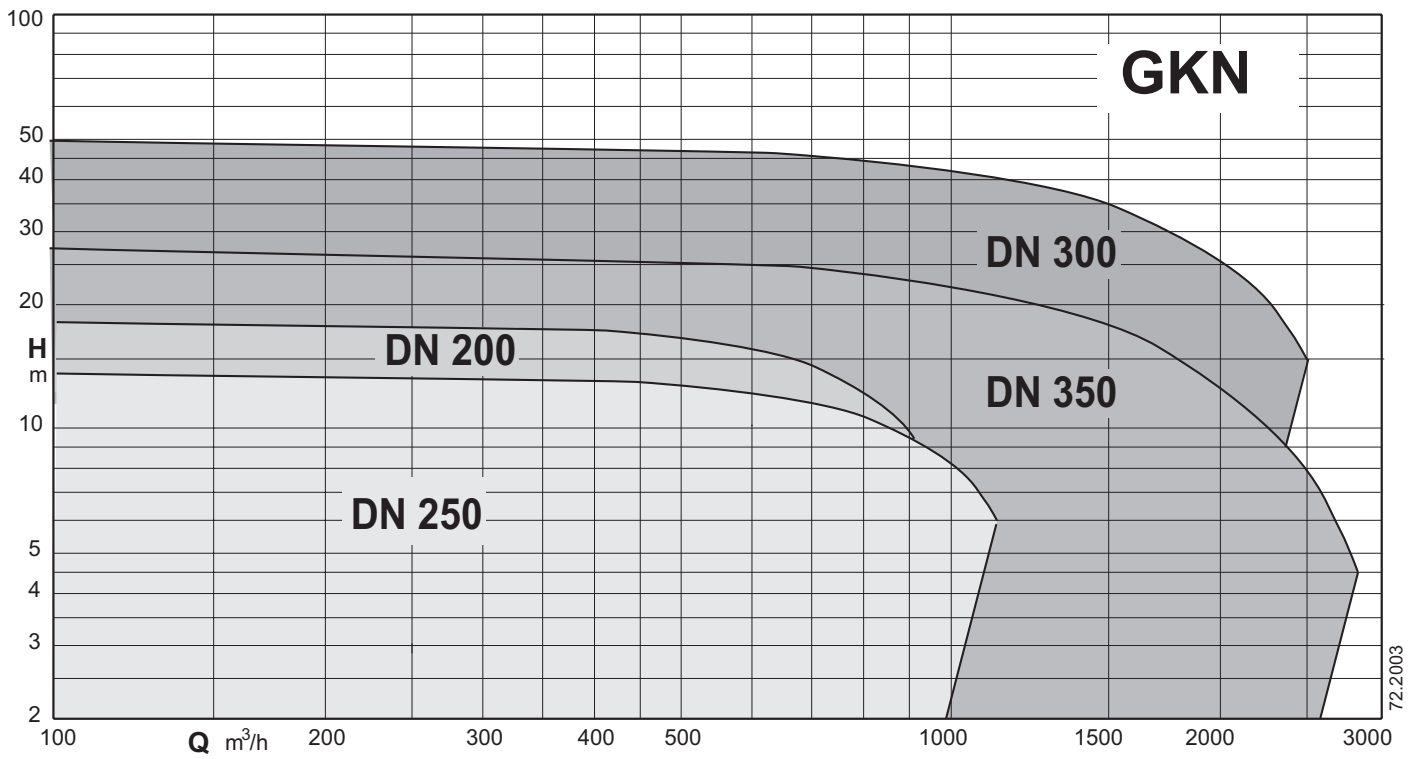

submersible pumps with channels impeller

Construction

Submersible pumps with multi-channel impeller.
 Characterised by good protection against clogging, large spherical passages, good wear resistance, low mechanical action on the fluid and high hydraulic efficiency at high flow rates.
 Low vibrations thanks to the dynamically balanced impeller.
 Delivery port DN 200-250-300-350.

Applications

For the movement of sewage and sewage grates.
 Particularly suitable for the emptying of sewage from cesspits or primary collection tanks or industrial waste water.
 They replace single-channel pumps when a high solids passage diameter is not required.
 Solid passage from 100 to 164 mm.

Operating conditions

Liquid temperature: from 0°C to +40°C.
 Maximum immersion depth: 20m (with cable of suitable length).
 Maximum working pressure: 80 m.w.c.
 pH of the liquid to be lifted: 4 ÷ 10
 Continuous service (with water at minimum immersion level).

Materials

Pump casing: cast iron EN-GJL250 UNI-EN 1561-11
 Impeller: cast iron EN-GJL250 UNI-EN 1561-11
 Motor casing: cast iron EN-GJL250 UNI-EN 1561-11 / EN-GJL450 UNI-EN 1561-11
 Shaft: stainless steel X20Cr13 (AISI420)
 Mechanical seal pumps with insulation class H
 - motor side: graphite/ceramic
 - pump side: silicon/ceramic carbide
 Mechanical seal pumps with insulation class F
 - motor side: stainless steel/graphite
 - pump side: Silicon carbide/silicon carbide

Motor

Induction motor 4-6 or 8 poles, 50Hz
 400/690V ± 10%
 Isolation class: F or H
 Degree of protection: IP 68
 Max number of starts per hour:
 - 20 up to 5 kW
 - 15 up to 10 kW
 - 10 for higher powers
 Cable: length 10m
 Direction of rotation: clockwise top view
 Motor suitable for operation with frequency converter.

Designation

GKN4 200-100A-0260R
 GK = Series
 N = Multi-channel impeller
 4 = Number of poles
 200 = Delivery port diameter in mm
 100 = Free passage in mm
 A = Impeller trim
 0260 = Motor size kW x 10
 R = With cooling jacket

Technical data

TYPE	Dry chamber version		Probes		Cable		Class Isolation	Duck foot coupling	Submersible pump rest	Dry chamber pump rest	Dry chamber pump support
	Vertical	Horizontal	thermal	conductivity	NSSHOU-J	H07RN-F					
GKN6 200-100A-0075N	•	–	•	•	•	–	H	SAK 200-250-3	APK 150	APCK 200	SOK150/N3
GKN6 200-100G-0075N	•	–	•	•	•	–	H	SAK 200-250-3	APK 150	APCK 200	SOK150/N3
GKN6 200-100L-0075N	•	–	•	•	•	–	H	SAK 200-250-3	APK 150	APCK 200	SOK150/N3
GKN6 200-100A-0110N	•	–	•	•	•	–	H	SAK 200-250-3	APK 150	APCK 200	–
GKN6 200-100G-0110N	•	–	•	•	•	–	H	SAK 200-250-3	APK 150	APCK 200	–
GKN6 200-100L-0110N	•	–	•	•	•	–	H	SAK 200-250-3	APK 150	APCK 200	–
GKN4 200-100A-0260N	•	–	•	•	•	–	H	SAK 200-250-3	APK 150	APCK 200	–
GKN4 200-100D-0210N	•	–	•	•	•	–	H	SAK 200-250-3	APK 150	APCK 200	–
GKN4 200-100G-0193N	•	–	•	•	•	–	H	SAK 200-250-3	APK 150	APCK 200	–
GKN4 200-100L-0165N	•	–	•	•	•	–	H	SAK 200-250-3	APK 150	APCK 200	–
GKN6 250-115A-0195P	•	–	•	•	•	–	H	SAK 250-300-3	APK 250	APCK 250	–
GKN6 250-115D-0150P	•	–	•	•	•	–	H	SAK 250-300-3	APK 250	APCK 250	–
GKN6 250-115I-0110P	•	–	•	•	•	–	H	SAK 250-300-3	APK 250	APCK 250	–
GKN8 300-143A-0210Z	–	–	•	•	•	•	F	SAK 300-350-3	APK 350	–	–
GKN8 300-143B-0210Z-R	•	•	•	•	•	•	F	SAK 300-350-3	–	APCK 300	SOK350-200
GKN8 300-143D-0170Z	–	–	•	•	•	•	F	SAK 300-350-3	APK 350	–	–
GKN8 300-143E-0170Z-R	•	•	•	•	•	•	F	SAK 300-350-3	–	APCK 300	SOK350-200
GKN6 300-143A-0510R	–	–	•	•	•	•	F	SAK 300-350-3	APK 350	–	–
GKN6 300-143B-0510R-R	•	•	•	•	•	•	F	SAK 300-350-3	–	APCK 300	SOK350-250
GKN6 300-143D-0420R	–	–	•	•	•	•	F	SAK 300-350-3	APK 350	–	–
GKN6 300-143E-0420R-R	•	•	•	•	•	•	F	SAK 300-350-3	–	APCK 300	SOK350-200
GKN6 300-143G-0340R	–	–	•	•	•	•	F	SAK 300-350-3	APK 350	–	–
GKN6 300-143H-0340R-R	•	•	•	•	•	•	F	SAK 300-350-3	–	APCK 300	SOK350-200
GKN6 300-143M-0250R	–	–	•	•	•	•	F	SAK 300-350-3	APK 350	–	–
GKN6 300-143N-0250R-R	•	•	•	•	•	•	F	SAK 300-350-3	–	APCK 300	SOK350-200

• = Standard
 – = Not present

o = Optional

= Version with oil chamber
 \$ = Version with cooling jacket

= In case of operation in a dry chamber or with a low level of the pumped liquid, it is necessary to introduce the cooling oil according to the quantities indicated in the use and maintenance manual

Technical data

TYPE	Dry chamber version		Probes		Cable		Class Isolation	Duck foot coupling	Submersible pump rest	Dry chamber pump rest	Dry chamber pump support
	Vertical	Horizontal	thermal	conductivity	NSSHOU-J	H07RN-F					
GKN8 350-143A-0420R	-	-	•	•	-	•	F	SAK 350-400-3	APK 350	-	-
GKN8 350-143B-0420R-R	\$	\$	•	•	-	•	F	SAK 350-400-3	-	APCK 350	SOK350-250
GKN8 350-143G-0340R	-	-	•	•	-	•	F	SAK 350-400-3	APK 350	-	-
GKN8 350-143H-0340R-R	\$	\$	•	•	-	•	F	SAK 350-400-3	-	APCK 350	SOK350-225
GKN8 350-143O-0250R	-	-	•	•	-	•	F	SAK 350-400-3	APK 350	-	-
GKN8 350-143P-0250R-R	\$	\$	•	•	-	•	F	SAK 350-400-3	-	APCK 350	SOK350-225
GKN8 350-143S-0210R	-	-	•	•	-	•	F	SAK 350-400-3	APK 350	-	-
GKN8 350-143T-0210R-R	\$	\$	•	•	-	•	F	SAK 350-400-3	-	APCK 350	SOK350-200
GKN6 350-164S-0510R	-	-	•	•	-	•	F	SAK 350-400-3A	APK 350	-	-
GKN6 350-164T-0510R-R	\$	\$	•	•	-	•	F	SAK 350-400-3A	-	APCK 350	SOK350-250
GKN6 350-164V-0420R	-	-	•	•	-	•	F	SAK 350-400-3A	APK 350	-	-
GKN6 350-164W-0420R-R	\$	\$	•	•	-	•	F	SAK 350-400-3A	-	APCK 350	SOK350-200
GKN4 300-143A-1800T	-	-	•	•	-	•	F	SAK 300-350-3A	APK 350	-	-
GKN4 300-143B-1800T-R	\$	\$	•	•	-	•	F	SAK 300-350-3A	-	APCK 300	SOK350-315
GKN4 300-143D-1450T	-	-	•	•	-	•	F	SAK 300-350-3A	APK 350	-	-
GKN4 300-143E-1450T-R	\$	\$	•	•	-	•	F	SAK 300-350-3A	-	APCK 300	SOK350-280
GKN4 300-143G-1200T	-	-	•	•	-	•	F	SAK 300-350-3A	APK 350	-	-
GKN4 300-143H-1200T-R	\$	\$	•	•	-	•	F	SAK 300-350-3A	-	APCK 300	SOK350-280
GKN4 300-143I-1000T	-	-	•	•	-	•	F	SAK 300-350-3A	APK 350	-	-
GKN4 300-143L-1000T-R	\$	\$	•	•	-	•	F	SAK 300-350-3A	-	APCK 300	SOK350-280
GKN4 300-143M-0900T	-	-	•	•	-	•	F	SAK 300-350-3A	APK 350	-	-
GKN4 300-143N-0820T	-	-	•	•	-	•	F	SAK 300-350-3A	APK 350	-	-
GKN4 300-143P-0900T-R	•	-	•	•	-	•	F	SAK 300-350-3A	-	APCK 300	SOK350-250
GKN4 300-143Q-0820T-R	\$	\$	•	•	-	•	F	SAK 300-350-3A	-	APCK 300	SOK350-250
GKN6 350-164A-1000T	-	-	•	•	-	•	F	SAK 350-400-3A	APK 350	-	-
GKN6 350-164B-1000T-R	\$	\$	•	•	-	•	F	SAK 350-400-3A	-	APCK 350	SOK350-280
GKN6 350-164G-0820T	-	-	•	•	-	•	F	SAK 350-400-3A	APK 350	-	-
GKN6 350-164H-0820T-R	\$	\$	•	•	-	•	F	SAK 350-400-3A	-	APCK 350	SOK350-280
GKN6 350-164O-0600T	-	-	•	•	-	•	F	SAK 350-400-3A	APK 350	-	-
GKN6 350-164P-0600T-R	\$	\$	•	•	-	•	F	SAK 350-400-3A	-	APCK 350	SOK350-280

• = Standard
- = Not present

o = Optional

= Version with oil chamber
\$ = Version with cooling jacket

= In case of operation in a dry chamber or with a low level of the pumped liquid, it is necessary to introduce the cooling oil according to the quantities indicated in the use and maintenance manual

Performance

n ≈ 950 1/min

Model	400V	690V	P2	Q = Flow													
				m³/h	0	108	126	144	162	180	216	252	288	324	360	450	540
				l/min		1800	2100	2400	2700	3000	3600	4200	4800	5400	6000	7500	9000
				H (m) = Total head													
GKN6 200-100L-0075N	15,8	9,1	7,5		5,9	-	4,8	4,6	4,5	4,3	3,9	3,5	3,1	2,7	2,3	-	-
GKN6 200-100G-0075N	15,8	9,1	7,5		7,7	-	6,1	5,9	5,7	5,6	5,2	4,8	4,4	3,9	3,4	2,2	-
GKN6 200-100A-0075N	15,8	9,1	7,5		10,4	-	-	-	7,9	7,7	7,3	6,9	6,4	5,9	5,3	3,8	2,1
GKN6 200-100L-0110N	23,8	13,7	11		5,9	5	4,8	4,6	4,4	4,3	4	3,7	3,3	3	2,5	-	-
GKN6 200-100G-0110N	23,8	13,7	11		8,1	-	-	6,4	6,2	6	5,6	5,3	4,9	4,4	4	2,7	-
GKN6 200-100A-0110N	23,8	13,7	11		11,6	-	-	-	8,2	8	7,6	7,2	6,9	6,5	6	4,7	3,1

n ≈ 1450 1/min

Model	400V	690V	P2	Q = Flow												
				m³/h	0	216	252	288	324	360	450	540	630	720	810	900
				l/min		3600	4200	4800	5400	6000	7500	9000	10500	12000	13500	15000
				H (m) = Total head												
GKN4 200-100L-0165N	31,2	18	16,5		12,9	10	9,5	9	8,6	8,1	6,9	5,4	3,6	-	-	-
GKN4 200-100G-0193N	38,8	22,4	19,3		18	14,2	13,6	13	12,4	11,9	10,4	8,8	7	4,9	2,9	-
GKN4 200-100D-0210N	39	22,5	21		20,1	-	14,9	14,2	13,6	13	11,6	10	8,1	6	3,8	-
GKN4 200-100A-0260N	47,2	27,3	26		24,9	18,1	17,6	17	16,5	15,9	14,5	12,9	11	8,7	6,1	3,7

n ≈ 950 1/min

Model	400V	690V	P2	Q = Flow													
				m³/h	0	252	288	324	360	450	540	630	720	810	900	990	1080
				l/min		4200	4800	5400	6000	7500	9000	10500	12000	13500	15000	16500	18000
				H (m) = Total head													
GKN6 250-115I-0110P	23,8	13,7	11		8,4	6,4	6,1	5,8	5,6	4,9	4	3,1	2,1	-	-	-	-
GKN6 250-115D-0150P	33	19,1	15		11,4	9,4	9,1	8,8	8,5	7,7	6,8	5,8	4,7	3,5	2,2	-	-
GKN6 250-115A-0195P	40,2	23,2	19,5		15	13,1	12,7	12,3	11,9	10,8	9,8	8,7	7,6	6,4	5,1	3,8	2,5

n ≈ 725 1/min

Model	400V	690V	P2	Q = Flow														
				m³/h	0	288	360	450	540	630	720	810	900	990	1080	1170	1260	1350
				l/min		4800	6000	7500	9000	10500	12000	13500	15000	16500	18000	19500	21000	22500
				H (m) = Total head														
GKN8 300-143D-0170Z	36,0	20,6	17		11,1	8,6	8,2	7,7	7,3	6,8	6,3	5,7	5	4,2	3,4	2,6	1,7	-
GKN8 300-143A-0210Z	44,1	25,2	21		13	10,1	9,8	9,4	8,9	8,3	7,7	6,9	6,2	5,4	4,6	3,8	3	2,2
GKN8 300-143E-0170Z-R	36,0	20,6	17		11,1	8,6	8,2	7,7	7,3	6,8	6,3	5,7	5	4,2	3,4	2,6	1,7	-
GKN8 300-143B-0210Z-R	44,1	25,2	21		13	10,1	9,8	9,4	8,9	8,3	7,7	6,9	6,2	5,4	4,6	3,8	3	2,2

n ≈ 950 1/min

Model	400V	690V	P2	Q = Flow													
				m³/h	0	324	360	450	540	630	720	900	1080	1260	1440	1620	1800
				l/min		5400	6000	7500	9000	10500	12000	15000	18000	21000	24000	27000	30000
				H (m) = Total head													
GKN6 300-143M-0250R	50,0	28,6	25		11,6	9,6	9,4	9	8,5	8,1	7,6	6,4	5,1	3,5	2	-	-
GKN6 300-143G-0340R	68,5	39,1	34		16,4	-	12,7	12,4	12	11,5	10,9	9,6	8	6,2	4,3	-	-
GKN6 300-143D-0420R	84,7	48,4	42		20,5	-	15,3	14,8	14,3	13,9	13,4	12,2	10,6	8,6	6,4	4,2	-
GKN6 300-143A-0510R	103	58,9	51		23,7	-	18	17,5	17	16,6	16,1	14,8	13,1	11	8,8	6,5	4,1
GKN6 300-143N-0250R-R	50,0	28,6	25		11,6	9,6	9,4	9	8,5	8,1	7,6	6,4	5,1	3,5	2	-	-
GKN6 300-143H-0340R-R	68,5	39,1	34		16,4	-	12,7	12,4	12	11,5	10,9	9,6	8	6,2	4,3	-	-
GKN6 300-143E-0420R-R	84,7	48,4	42		20,5	-	15,3	14,8	14,3	13,9	13,4	12,2	10,6	8,6	6,4	4,2	-
GKN6 300-143B-0510R-R	103	58,9	51		23,7	-	18	17,5	17	16,6	16,1	14,8	13,1	11	8,8	6,5	4,1

Performance

n ≈ 1450 1/min

Model	400V	690V	P2	Q = Flow																		
				m³/h	0																	
				l/min	540	630	720	810	900	990	1080	1170	1260	1440	1620	1800	1980	2160	2340	2520		
A			kW			H (m) = Total head																
GKN4 300-143N-0820T	148	84,5	82	30,8	24	22,9	21,9	20,8	19,8	18,8	17,8	16,8	15,8	13,8	11,7	9,5	7,2	4,5	1,6	-		
GKN4 300-143M-0900T	159	90,9	90	32,1	25,2	24,2	23,1	22,1	21	20	18,9	17,9	16,9	14,8	12,7	10,6	8,3	5,8	2,8	-		
GKN4 300-143I-1000T	184	105	100	34,4	27,5	26,4	25,4	24,3	23,2	22,1	21	19,9	18,9	16,7	14,5	12,2	9,8	7,4	4,9	2,3		
GKN4 300-143G-1200T	223	128	120	37,9	32,9	31,3	29,8	28,5	27,2	25,9	24,8	23,7	22,6	20,5	18,3	16,1	13,6	10,9	8,1	5,2		
GKN4 300-143D-1450T	262	150	145	48,3	38,4	37	35,7	34,5	33,3	32,1	30,9	29,7	28,4	25,7	22,8	20	17,2	14,6	12,2	10		
GKN4 300-143A-1800T	321	184	180	56,6	46,8	45,4	44,2	43,1	42	40,9	39,7	38,6	37,4	34,8	32	29	25,9	22,6	19,3	15,9		
GKN4 300-143Q-0820T-R	148	84,5	82	30,8	24	22,9	21,9	20,8	19,8	18,8	17,8	16,8	15,8	13,8	11,7	9,5	7,2	4,5	1,6	-		
GKN4 300-143P-0900T-R	159	90,9	90	32,1	25,2	24,2	23,1	22,1	21	20	18,9	17,9	16,9	14,8	12,7	10,6	8,3	5,8	2,8	-		
GKN4 300-143L-1000T-R	184	105	100	34,4	27,5	26,4	25,4	24,3	23,2	22,1	21	19,9	18,9	16,7	14,5	12,2	9,8	7,4	4,9	2,3		
GKN4 300-143H-1200T-R	223	128	120	37,9	32,9	31,3	29,8	28,5	27,2	25,9	24,8	23,7	22,6	20,5	18,3	16,1	13,6	10,9	8,1	5,2		
GKN4 300-143E-1450T-R	262	150	145	48,3	38,4	37	35,7	34,5	33,3	32,1	30,9	29,7	28,4	25,7	22,8	20	17,2	14,6	12,2	10		
GKN4 300-143B-1800T-R	321	184	180	56,6	46,8	45,4	44,2	43,1	42	40,9	39,7	38,6	37,4	34,8	32	29	25,9	22,6	19,3	15,9		

n ≈ 725 1/min

Model	400V	690V	P2	Q = Flow																
				m³/h	0															
				l/min	252	270	360	450	540	630	720	900	1080	1260	1440	1620	1800	1980	2160	
A			kW			H (m) = Total head														
GKN8 350-143S-0210R	44,1	25,2	21	8,4	7,2	7,2	7,1	7	6,8	6,5	6,2	5,6	4,8	3,8	2,8	1,8	-	-	-	-
GKN8 350-143O-0250R	58,5	33,4	25	10,1	-	-	8,7	8,5	8,3	8	7,6	6,8	5,9	4,9	3,8	2,5	-	-	-	-
GKN8 350-143G-0340R	80,0	45,7	34	13,9	-	-	12	11,5	11,1	10,7	10,3	9,4	8,4	7,3	6,1	4,8	3,4	2	-	-
GKN8 350-143A-0420R	90,5	51,7	42	16,1	-	-	13,5	13,1	12,8	12,4	12	11,1	10,1	9,1	8	6,7	5,3	3,9	2,4	-
GKN8 350-143T-0210R-R	44,1	25,2	21	8,4	7,2	7,2	7,1	7	6,8	6,5	6,2	5,6	4,8	3,8	2,8	1,8	-	-	-	-
GKN8 350-143P-0250R-R	58,5	33,4	25	10,1	-	-	8,7	8,5	8,3	8	7,6	6,8	5,9	4,9	3,8	2,5	-	-	-	-
GKN8 350-143H-0340R-R	80,0	45,7	34	13,9	-	-	12	11,5	11,1	10,7	10,3	9,4	8,4	7,3	6,1	4,8	3,4	2	-	-
GKN8 350-143B-0420R-R	90,5	51,7	42	16,1	-	-	13,5	13,1	12,8	12,4	12	11,1	10,1	9,1	8	6,7	5,3	3,9	2,4	-

n ≈ 950 1/min

Model	400V	690V	P2	Q = Flow																	
				m³/h	0																
				l/min	720	810	900	990	1080	1170	1260	1440	1620	1800	1980	2160	2340	2520	2700	2880	
A			kW			H (m) = Total head															
GKN6 350-164V-0420R	84,7	48,4	42	12,7	10,2	9,9	9,6	9,3	8,9	8,5	8,1	7,1	5,9	4,6	3,1	1,8	-	-	-	-	
GKN6 350-164S-0510R	103	58,9	51	15,2	12,2	11,9	11,6	11,2	10,8	10,3	9,8	8,7	7,4	6,1	4,7	3,4	2	-	-	-	-
GKN6 350-164W-0420R-R	84,7	48,4	42	12,7	10,2	9,9	9,6	9,3	8,9	8,5	8,1	7,1	5,9	4,6	3,1	1,8	-	-	-	-	
GKN6 350-164T-0510R-R	103	58,9	51	15,2	12,2	11,9	11,6	11,2	10,8	10,3	9,8	8,7	7,4	6,1	4,7	3,4	2	-	-	-	-
GKN6 350-164O-0600T	110	62,7	60	21,1	16,4	15,8	15,1	14,4	13,8	13,1	12,3	10,9	9,4	8	6,5	5,2	3,9	2,7	-	-	-
GKN6 350-164G-0820T	145	82,7	82	27,2	20,7	20	19,3	18,6	17,9	17,1	16,4	14,9	13,3	11,7	10	8,4	6,8	5,2	3,6	-	-
GKN6 350-164A-1000T	177	101	100	31,7	24,9	24	23,2	22,4	21,6	20,8	19,9	18,3	16,6	14,9	13,3	11,6	10	8,3	6,8	5,2	-
GKN6 350-164P-0600T-R	110	62,7	60	21,1	16,4	15,8	15,1	14,4	13,8	13,1	12,3	10,9	9,4	8	6,5	5,2	3,9	2,7	-	-	-
GKN6 350-164H-0820T-R	145	82,7	82	27,2	20,7	20	19,3	18,6	17,9	17,1	16,4	14,9	13,3	11,7	10	8,4	6,8	5,2	3,6	-	-
GKN6 350-164B-1000T-R	177	101	100	31,7	24,9	24	23,2	22,4	21,6	20,8	19,9	18,3	16,6	14,9	13,3	11,6	10	8,3	6,8	5,2	-

Characteristic curves

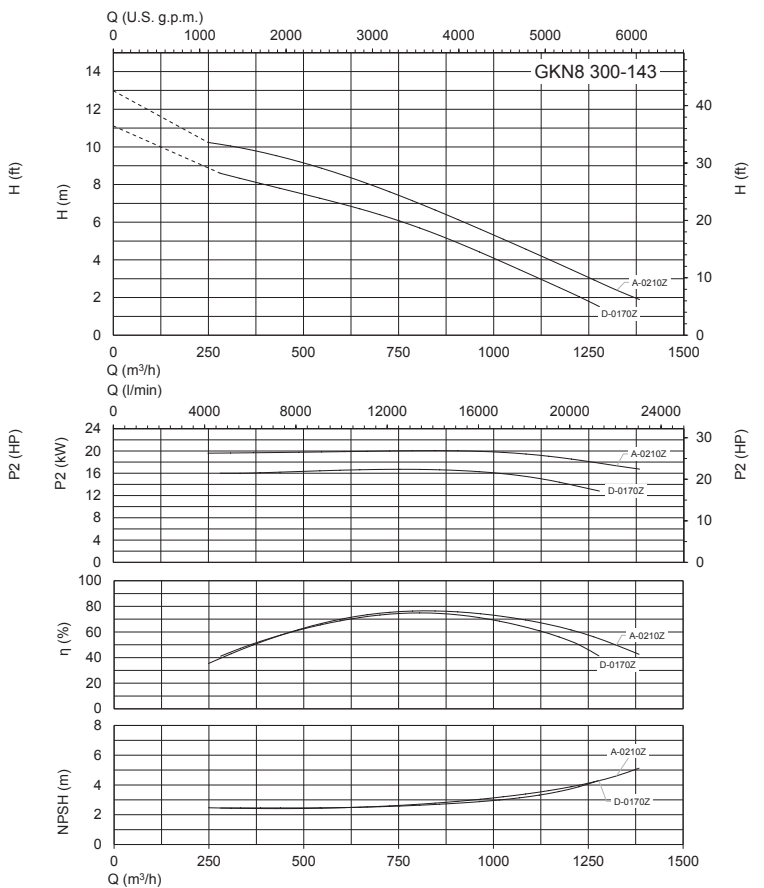
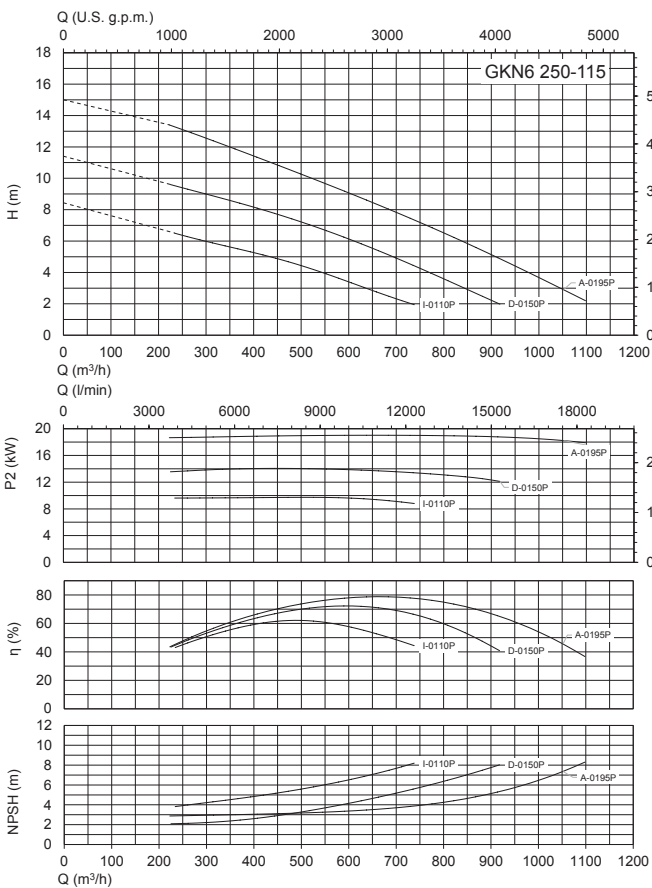
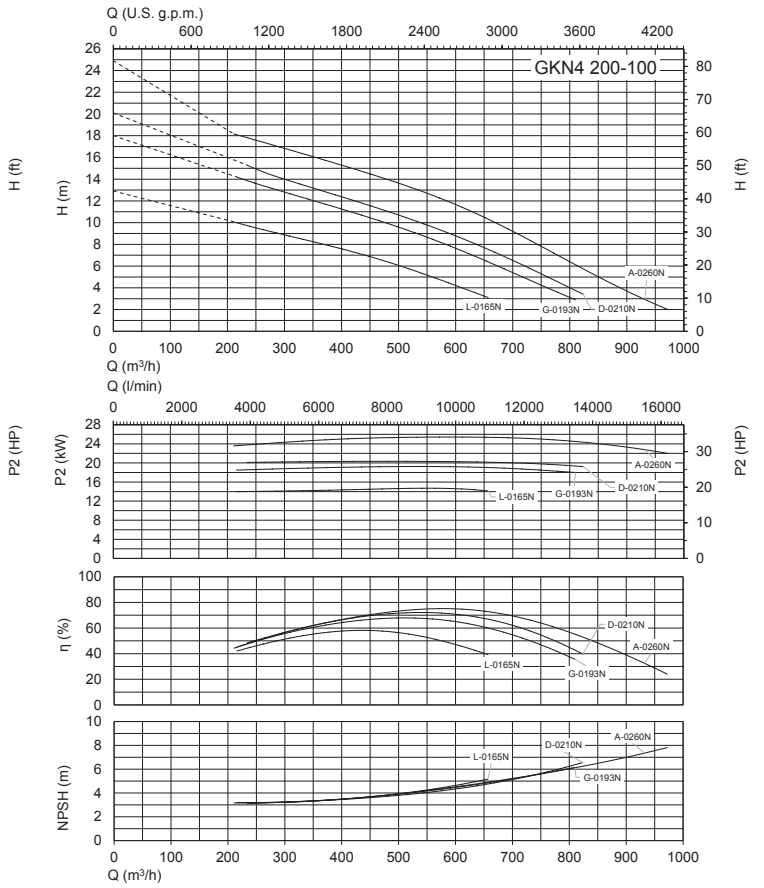
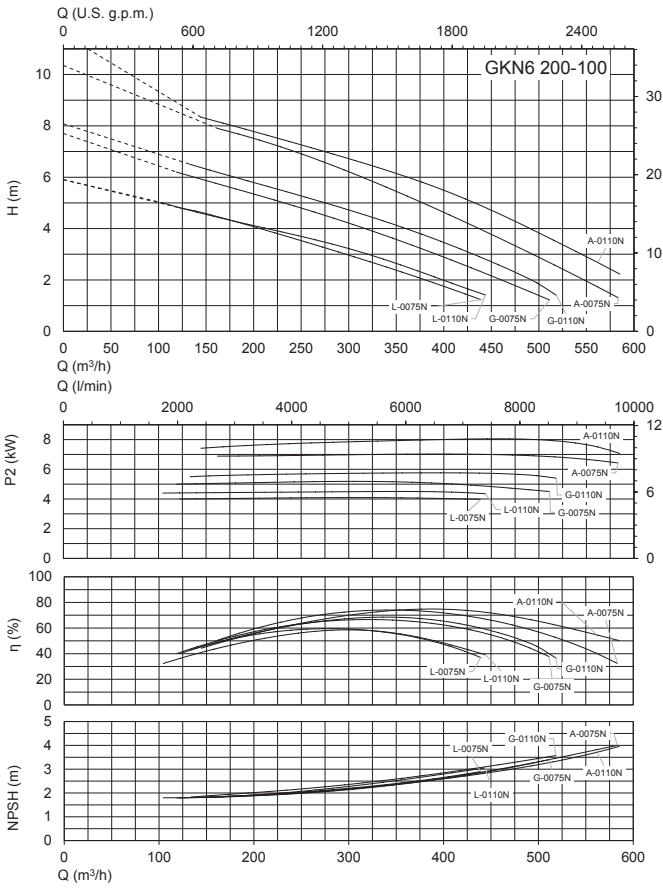

Characteristic curves

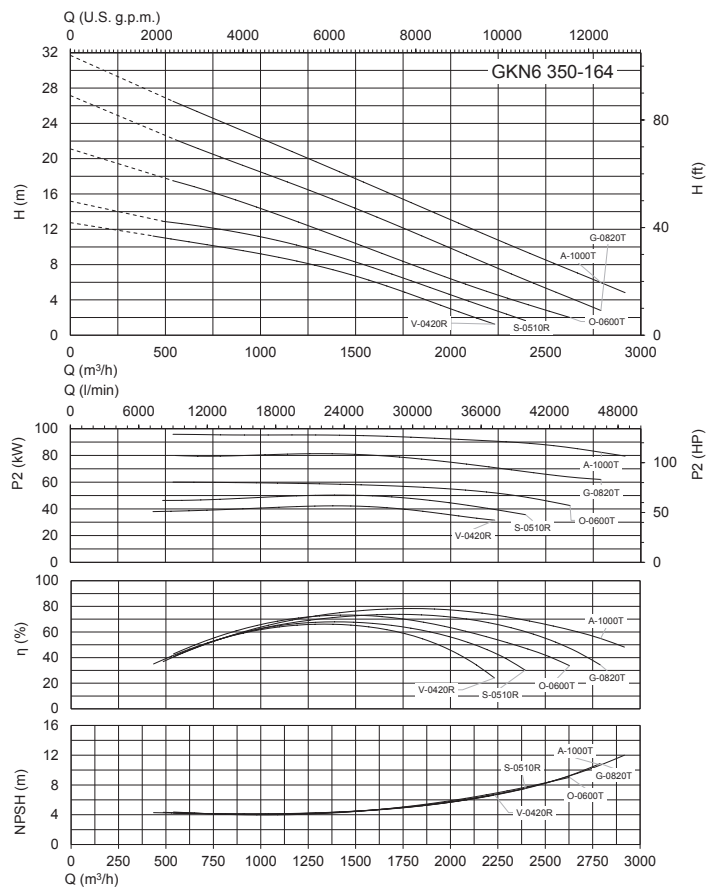
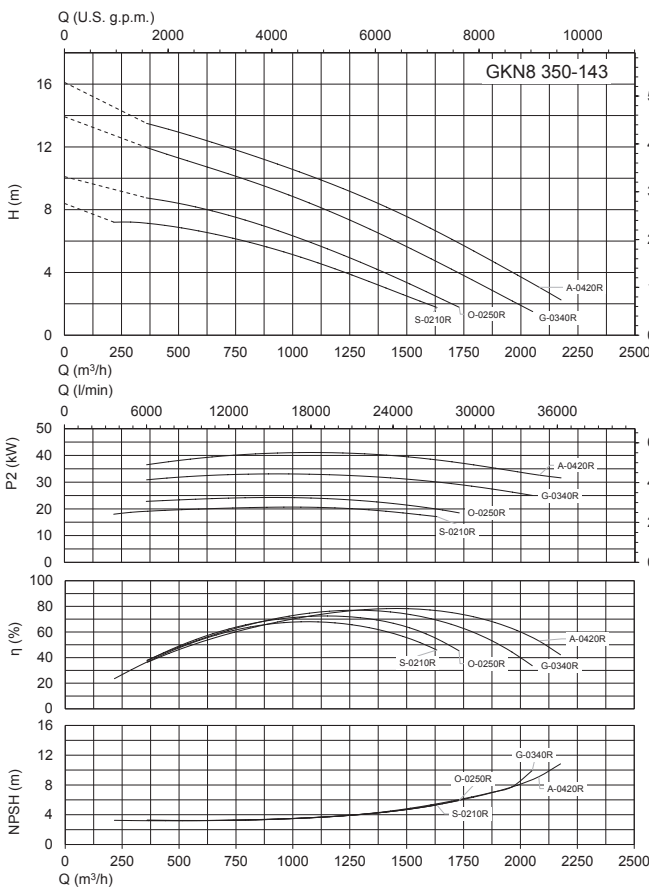
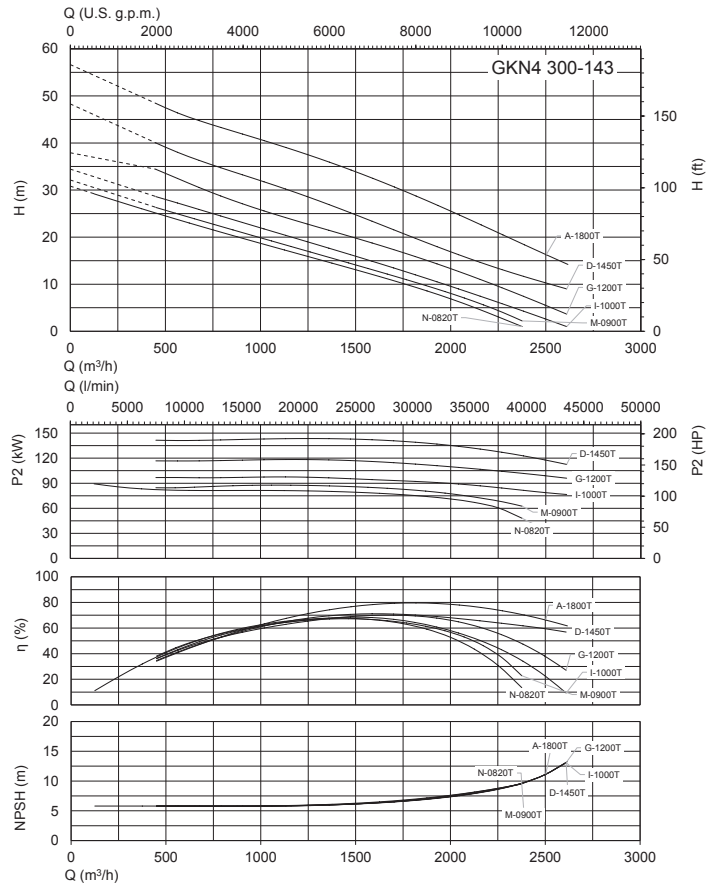
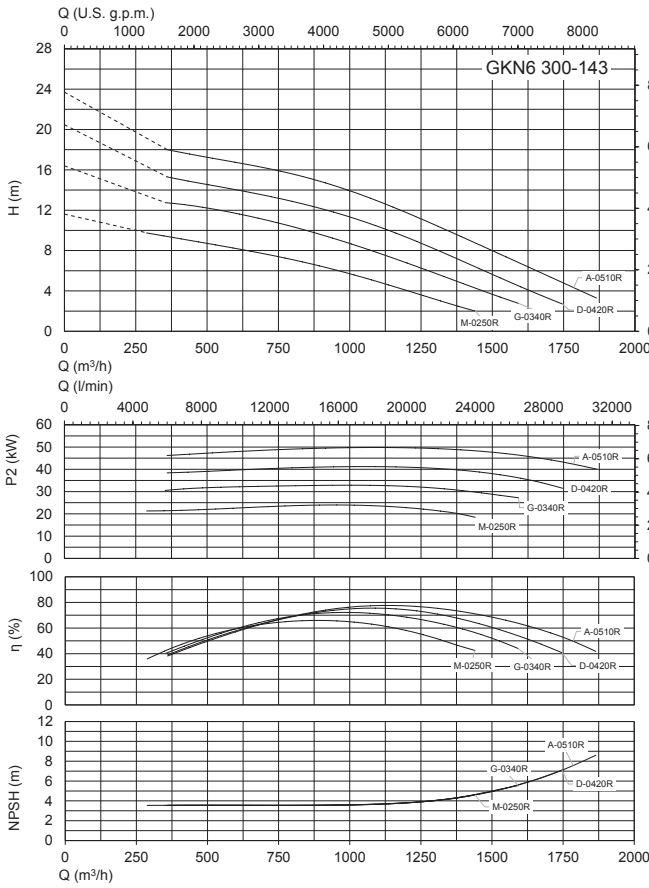

Dimensions and weights

Duck foot coupling

SAK

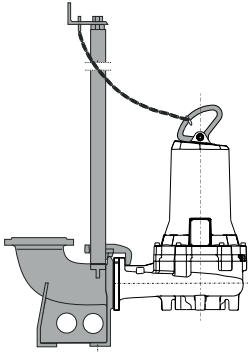

Submersible pump rest

APK

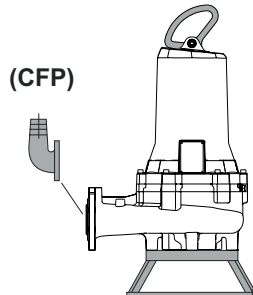

Dry chamber pump rest

APCK

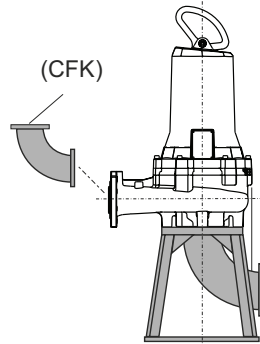

Dry chamber pump support

SOK

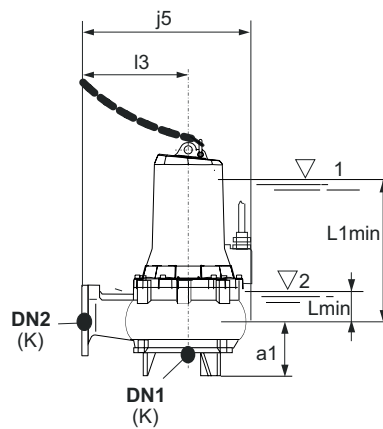
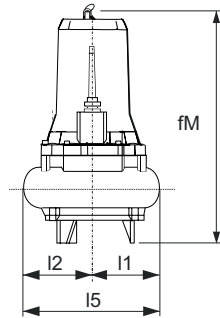
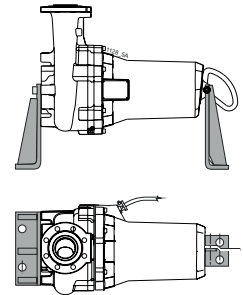

TYPE	mm												Kg Weight
	DN1	DN2	a1	fM	j5	K	l1	l2	l5	l5	L1min	Lmin	
GKN6 200-100L-0075N	200	200	170	846.9	840	10	240	340	550	580	446	120	235
GKN6 200-100G-0075N	200	200	170	846.9	840	10	240	340	550	580	446	120	235.3
GKN6 200-100A-0075N	200	200	170	846.9	840	10	240	340	550	580	446	120	236.7

L1min = Minimum submergence depth for motor without casing with continuous duty S1 (NPSHR permitting)

Lmin = Minimum submergence depth for motor without casing with intermittent duty S3 (NPSHR permitting)

Dimensions and weights

Duck foot coupling

SAK

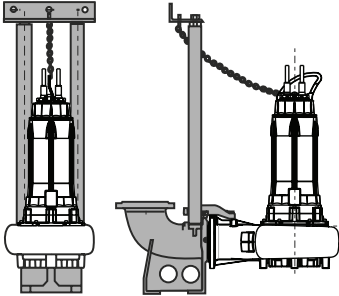

Submersible pump rest

APK

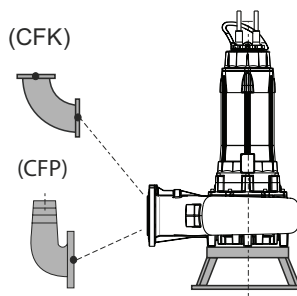

Dry chamber pump rest

APCK

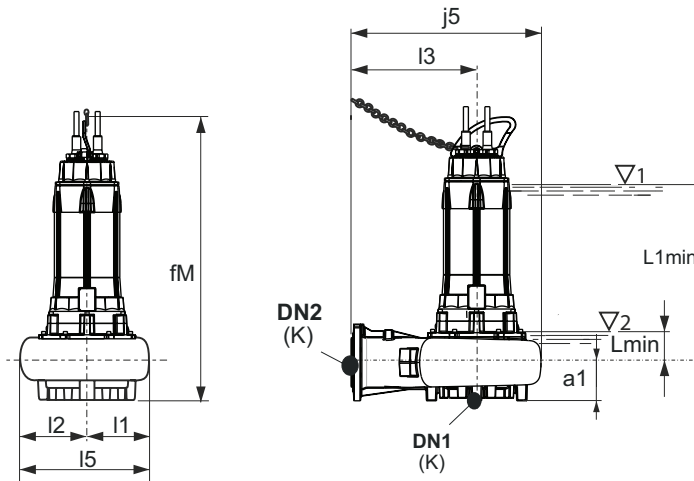
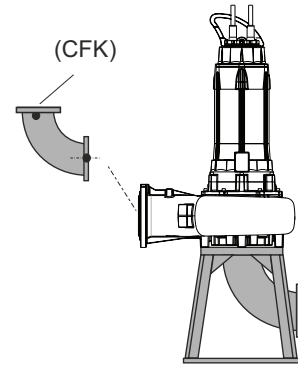

TYPE	mm												Kg Weight
	DN1	DN2	a1	fM	j5	K	l1	l2	l5	l5	L1min	Lmin	
GKN6 200-100L-0110N	200	200	170	1259	835	16	236	334	550	570	804	183	387.3
GKN6 200-100G-0110N	200	200	170	1259	835	16	236	334	550	570	804	183	388
GKN6 200-100A-0110N	200	200	170	1259	835	16	236	334	550	570	804	183	389.7

TYPE	mm												Kg Weight
	DN1	DN2	a1	fM	j5	K	l1	l2	l5	l5	L1min	Lmin	
GKN4 200-100L-0165N	200	200	170	1259	835	16	236	334	550	570	804	183	374.1
GKN4 200-100G-0193N	200	200	170	1259	835	16	236	334	550	570	804	183	396.6
GKN4 200-100D-0210N	200	200	170	1259	835	16	236	334	550	570	804	183	421.2
GKN4 200-100A-0260N	200	200	170	1259	835	16	236	334	550	570	804	183	404.9

TYPE	mm												Kg Weight
	DN1	DN2	a1	fM	j5	K	l1	l2	l5	l5	L1min	Lmin	
GKN6 250-115I-0110P	250	250	200	1305	843	10	282	404	500	686	820	199	412.8
GKN6 250-115D-0150P	250	250	200	1305	843	10	282	404	500	686	820	199	477.8
GKN6 250-115A-0195P	250	250	200	1305	843	10	282	404	500	686	820	199	524.3

L1min = Minimum submergence depth for motor without casing with continuous duty S1 (NPSHR permitting)
 Lmin = Minimum submergence depth for motor without casing with intermittent duty S3 (NPSHR permitting)

Dimensions and weights

Duck foot coupling

SAK

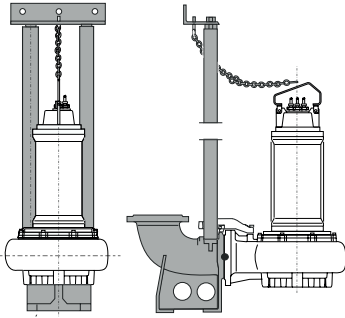

Submersible pump rest

APK

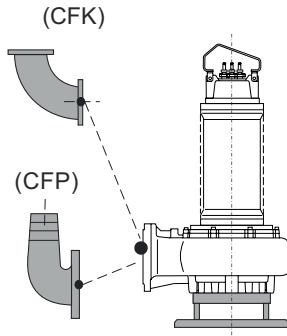

Dry chamber pump rest

APCK

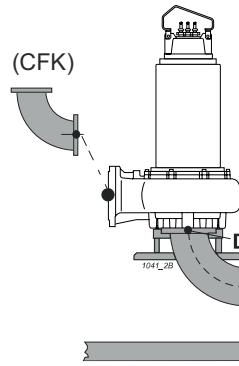

Dry chamber pump support

SOK

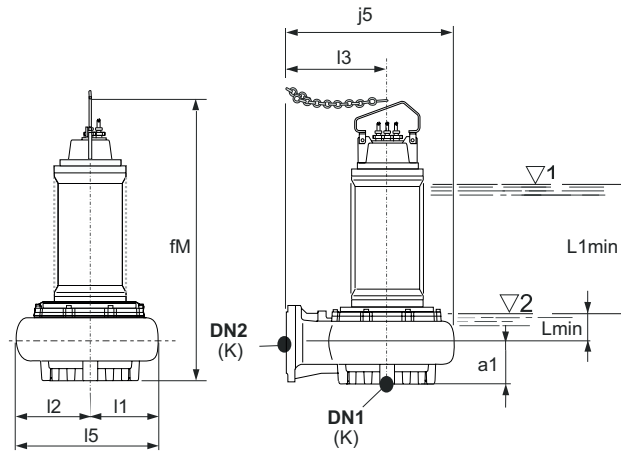
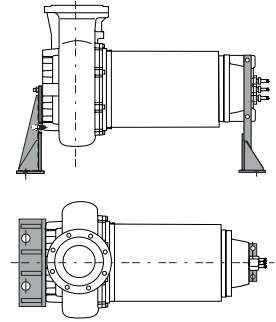

TYPE	mm												Kg Weight
	DN1	DN2	a1	fM	j5	K	l1	l2	l5	l5	L1min	Lmin	
GKN8 300-143D-0170Z	300	300	230	1599.5	1030	10	340	480	620	820	910	165	656
GKN8 300-143A-0210Z	300	300	230	1599.5	1030	10	340	480	620	820	910	165	676
GKN8 300-143E-0170Z-R	300	300	230	1599.5	1030	10	340	480	620	820	910	165	761
GKN8 300-143B-0210Z-R	300	300	230	1599.5	1030	10	340	480	620	820	910	165	691

TYPE	mm												Kg Weight
	DN1	DN2	a1	fM	j5	K	l1	l2	l5	l5	L1min	Lmin	
GKN6 300-143M-0250R	300	300	230	1599.5	1030	10	340	480	620	820	910	165	656
GKN6 300-143G-0340R	300	300	230	1599.5	1030	10	340	480	620	820	910	165	676
GKN6 300-143D-0420R	300	300	230	1599.5	1030	10	340	480	620	820	910	165	788
GKN6 300-143A-0510R	300	300	230	1631.5	1030	10	340	480	620	820	910	165	1026
GKN6 300-143N-0250R-R	300	300	230	1599.5	1030	10	340	480	620	820	910	165	671
GKN6 300-143H-0340R-R	300	300	230	1599.5	1030	10	340	480	620	820	910	165	696
GKN6 300-143E-0420R-R	300	300	230	1599.5	1030	10	340	480	620	820	910	165	804
GKN6 300-143B-0510R-R	300	300	230	1631.5	1030	10	340	480	620	820	910	165	1046

L1min = Minimum submergence depth for motor without casing with continuous duty S1 (NPSHR permitting)

Lmin = Minimum submergence depth for motor without casing with intermittent duty S3 (NPSHR permitting)

Dimensions and weights

Duck foot coupling

SAK

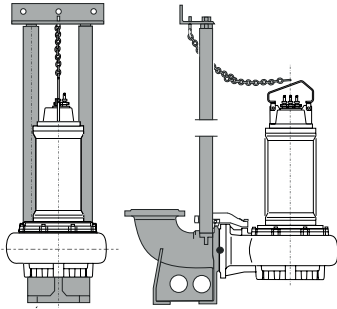

Submersible pump rest

APK

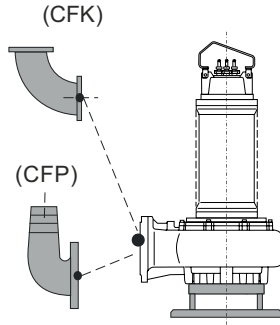

Dry chamber pump rest

APCK

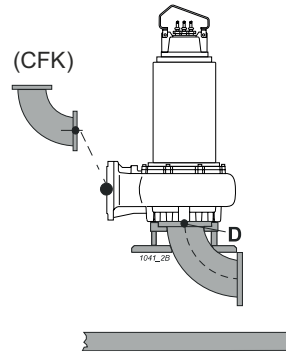

Dry chamber pump support

SOK

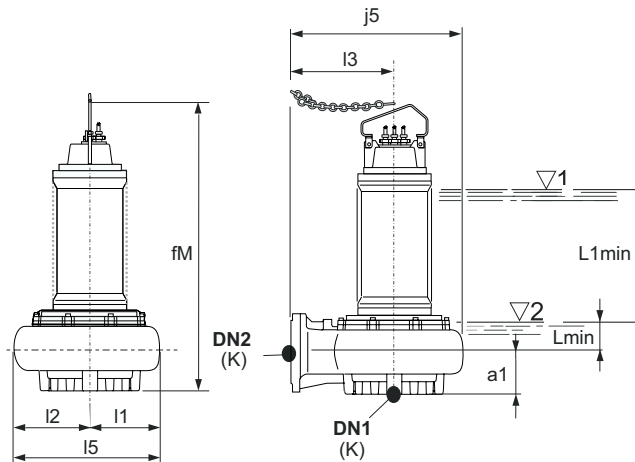
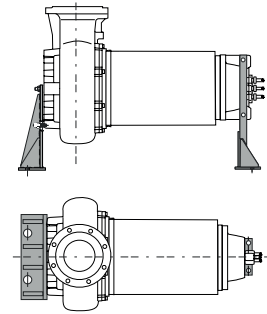

TYPE			mm										Kg
	DN1	DN2	a1	fM	j5	K	l1	l2	l5	l5	L1min	Lmin	Weight
GKN8 350-143S-0210R	350	350	268	1640.5	1170	10	385	550	700	935	997	192	785
GKN8 350-143O-0250R	350	350	268	1662.5	1170	10	385	550	700	935	912	167	970
GKN8 350-143G-0340R	350	350	268	1662.5	1170	10	385	550	700	935	912	167	1070
GKN8 350-143A-0420R	350	350	268	1672.5	1170	10	385	550	700	935	1002	192	1155
GKN8 350-143T-0210R-R	350	350	268	1640.5	1170	10	385	550	700	935	997	192	805
GKN8 350-143P-0250R-R	350	350	268	1662.5	1170	10	385	550	700	935	912	167	990
GKN8 350-143H-0340R-R	350	350	268	1662.5	1170	10	385	550	700	935	912	167	1025
GKN8 350-143B-0420R-R	350	350	268	1672.5	1170	10	385	550	700	935	1002	192	1175

TYPE			mm										Kg
	DN1	DN2	a1	fM	j5	K	l1	l2	l5	l5	L1min	Lmin	Weight
GKN6 350-164V-0420R	350	350	268	1640.5	1170	10	385	550	700	935	997	192	865
GKN6 350-164S-0510R	350	350	268	1672.5	1170	10	385	550	700	935	1002	192	1198
GKN6 350-164W-0420R-R	350	350	268	1640.5	1170	10	385	550	700	935	997	192	880
GKN6 350-164T-0510R-R	350	350	268	1672.5	1170	10	385	550	700	935	1002	192	1219
GKN6 350-164O-0600T	350	350	268	1908	1170	10	385	550	700	935	1177	192	1409
GKN6 350-164G-0820T	350	350	268	1908	1170	10	385	550	700	935	1177	192	1482
GKN6 350-164A-1000T	350	350	268	1908	1170	10	385	550	700	935	1177	192	1544
GKN6 350-164P-0600T-R	350	350	268	1908	1170	10	385	550	700	935	1177	192	1642
GKN6 350-164H-0820T-R	350	350	268	1908	1170	10	385	550	700	935	1177	192	1715
GKN6 350-164B-1000T-R	350	350	268	1908	1170	10	385	550	700	935	1177	192	1778

L1min = Minimum submergence depth for motor without casing with continuous duty S1 (NPSHR permitting)

Lmin = Minimum submergence depth for motor without casing with intermittent duty S3 (NPSHR permitting)

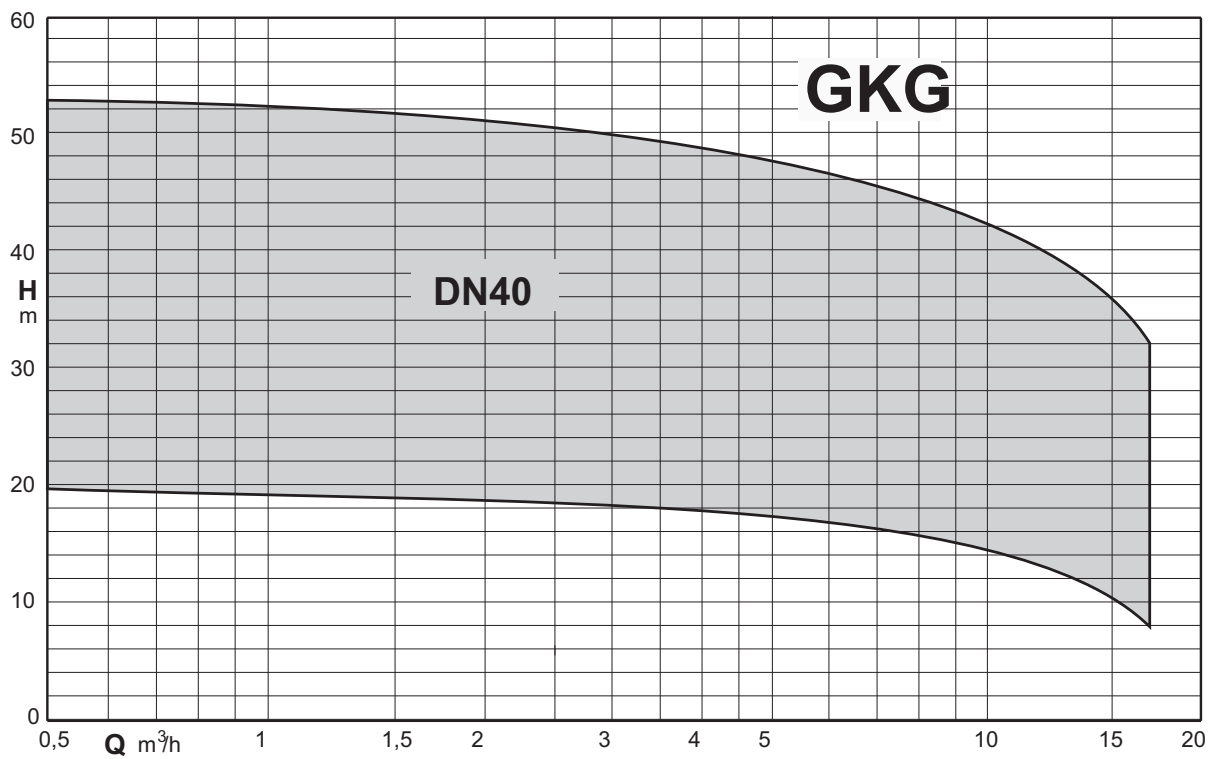
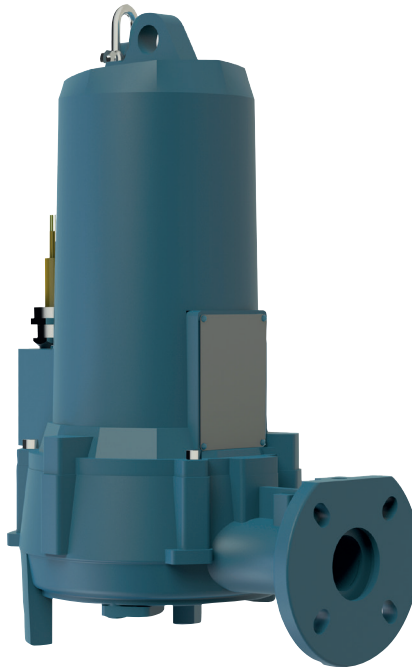

Submersible pumps with high power grinder

Construction

Submersible pumps with high cutting power shredder system.
 Made of very hard stainless steel, the shape of the shredder ensures long-life and fade-free shredding capacity.
 No particular tools are required to replace this part.
 Delivery port DN 40.

Applications

To move water containing long filamentary materials, paper or textile material.
 They are particularly suitable for the disposal of waste water in domestic, residential and industrial use.
 Solid passage 4 mm.

Operating conditions

Liquid temperature up to 40°C.
 Maximum immersion depth: 20m (with cable of suitable length).
 Maximum working pressure: 80 m.w.c.
 pH of the liquid to be lifted: 6 ÷ 10
 Continuous service (with water at minimum immersion level).

Materials

Pump casing: cast iron EN-GJL250 UNI-EN 1561-11
 Impeller: cast iron EN-GJL250 UNI-EN 1561-11
 Motor casing: cast iron EN-GJL250 UNI-EN 1561-11
 Shaft: stainless steel X20Cr13 (AISI420)
 Motor side mechanical seal: graphite/ceramic
 Pump side mechanical seal: silicon carbide/ceramic

Motor

Induction motor 2.4 poles, 50Hz
Three-phase version: 400V ± 10% up to 4.8 kW
 400/690V ± 10% from 5.8 kW
 Isolation class: H
 Degree of protection: IP 68
 Max number of starts per hour: 20 at regular intervals
 Cable: length 10m
 Direction of rotation: clockwise top view
 Motor suitable for operation with frequency converter.

Designation

GKKG2 40-4T-0020
 GK = Series
 G = Impeller with shredder system
 2 = Number of poles
 40 = Delivery port diameter in mm
 4 = Free passage in mm
 T = Impeller trim
 0020 = Motor size kW x 10

Technical data

TYPE	Dry chamber version		Probes		Cable		Class Isolation	Duck foot coupling	Duck foot coupling	Threaded bend
	Vertical	Horizontal	thermal	conductivity	NSSHOU-J	H07RN-F				
GKKG2 40-4T-0020F	-	-	o	o	-	•	H	SAK 40-G11/2A	SAK 40-G11/2-3/4	CFF 1 1/2"
GKKG2 40-4R-0020F	-	-	o	o	-	•	H	SAK 40-G11/2A	SAK 40-G11/2-3/4	CFF 1 1/2"
GKKG2 40-4D-0020F	-	-	o	o	-	•	H	SAK 40-G11/2A	SAK 40-G11/2-3/4	CFF 1 1/2"
GKKG2 40-4G-0020F	-	-	o	o	-	•	H	SAK 40-G11/2A	SAK 40-G11/2-3/4	CFF 1 1/2"
GKKG2 40-4P-0025F	-	-	o	o	-	•	H	SAK 40-G11/2A	SAK 40-G11/2-3/4	CFF 1 1/2"
GKKG2 40-4A-0025F	-	-	o	o	-	•	H	SAK 40-G11/2A	SAK 40-G11/2-3/4	CFF 1 1/2"
GKKG2 40-4G-0038H	•	•	•	•	•	-	H	SAK 40-G11/2A	SAK 40-G11/2-3/4	CFF 1 1/2"
GKKG2 40-4D-0048H	•	•	•	•	•	-	H	SAK 40-G11/2A	SAK 40-G11/2-3/4	CFF 1 1/2"
GKKG2 40-4A-0065H	•	•	•	•	•	-	H	SAK 40-G11/2A	SAK 40-G11/2-3/4	CFF 1 1/2"

• = Standard - = Not present o = Optional

Performance

n ≈ 2850 1/min

Model	400V A	400V A	690V A	P2 kW	Q = Flow													
					m³/h	0	1,4	1,8	2,2	2,5	2,9	3,2	3,6	7,2	10,8	14,4	18	
					l/min	0	23,33	30	36,66	41,66	48,33	53,33	60	120	180	240	300	
H (m) = Total head																		
GKG2 40-4T-0020F	4,1	-	-	2	23,3	22,2	22	21,8	21,6	21,4	21,2	21	18,9	16	-	-		
GKG2 40-4R-0020F	4,1	-	-	2	27,5	26,4	26,1	25,9	25,7	25,5	25,2	25	22,6	19,2	-	-		
GKG2 40-4D-0020F	4,1	-	-	2	23,8	23	22,9	22,7	22,5	22,3	22,2	22	20,3	18,3	15,4	10,6		
GKG2 40-4G-0020F	4,1	-	-	2	20,3	19,8	19,6	19,5	19,4	19,2	19,1	19	17,5	15,6	12,9	8,7		
GKG2 40-4P-0025F	5,5	-	-	2,5	33	31,4	31,1	30,9	30,7	30,4	30,2	30	27,5	23,9	-	-		
GKG2 40-4A-0025F	5,5	-	-	2,5	28,1	27	26,7	26,5	26,3	26	25,9	25,7	24,1	22,3	19,6	14,5		
GKG2 40-4G-0038H	7,5	-	-	3,8	37,5	36,6	36,3	36,1	35,8	35,5	35,3	35	31,9	28,7	25,4	19,3		
GKG2 40-4D-0048H	8,9	-	-	4,8	44,3	42,9	42,5	42,3	42	41,7	41,4	41,1	38,3	34,7	30,3	-		
GKG2 40-4A-0065H	-	11,9	6,9	6,5	52,6	50,9	50,5	50,1	49,7	49,3	48,9	48,5	44,6	40,7	36,9	30,9		

Characteristic curves

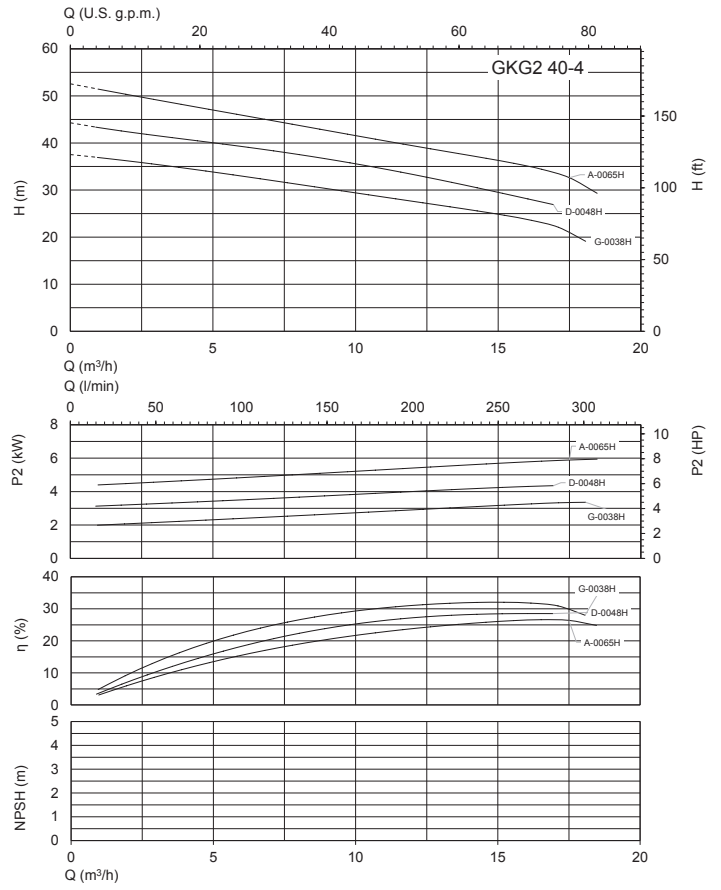
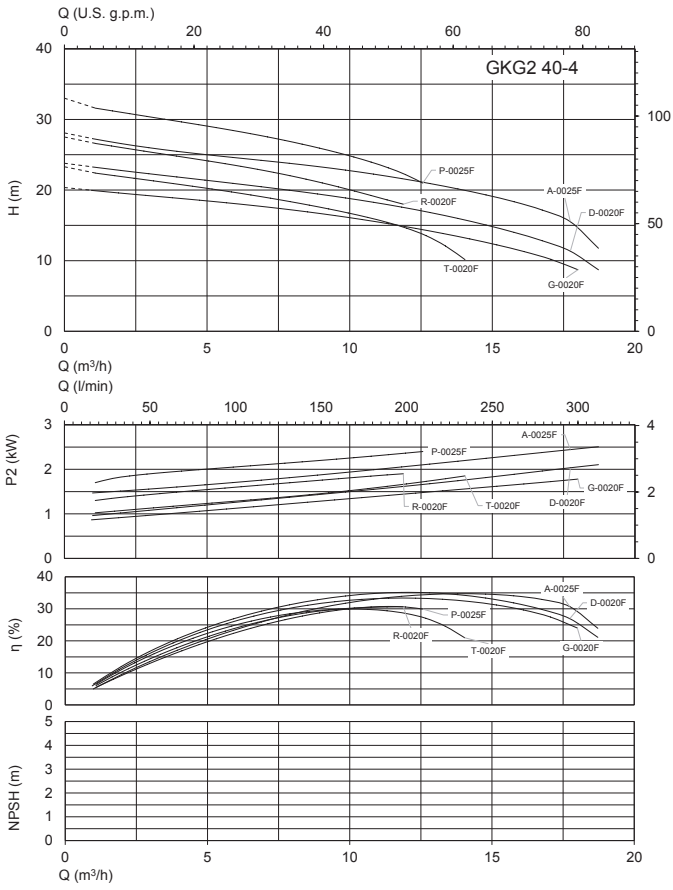

Dimensions and weights

Duck foot coupling

SAK 40-G11/2A

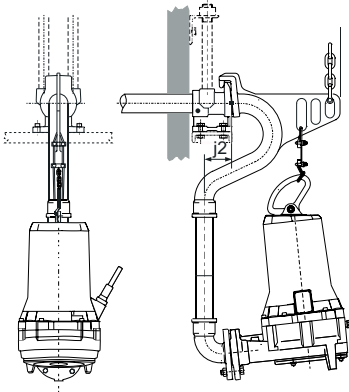

Submersible pump rest

SAK 40-G11/2-3/4

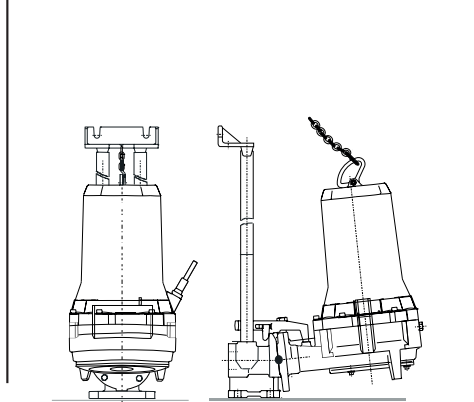

Submersible pump with bend

CFF

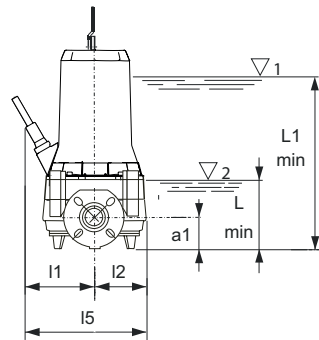
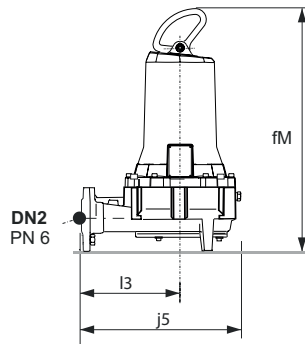
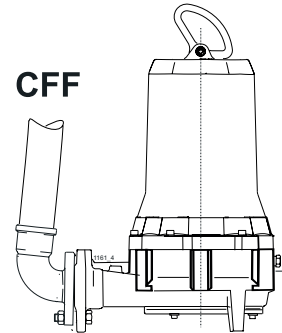

TYPE	DN2	mm										Kg Weight
		a1	fM	j5	K	l1	l2	l5	l5	L1min	Lmin	
GKG2 40-4T-0020F	40	73	476	338	6	112	112	200	224	261	61	52
GKG2 40-4R-0020F	40	73	476	338	6	112	112	200	224	261	61	52
GKG2 40-4D-0020F	40	73	476	338	6	112	112	200	224	261	61	52
GKG2 40-4G-0020F	40	73	476	338	6	112	112	200	224	261	61	52
GKG2 40-4P-0025F	40	73	476	338	6	112	112	200	224	261	61	48
GKG2 40-4A-0025F	40	73	476	338	6	112	112	200	224	261	61	50
GKG2 40-4G-0038H	40	73	571	373	6	204.5	136.5	240	341	317	49	81.8
GKG2 40-4D-0048H	40	73	571	373	6	204.5	136.5	240	341	317	49	76
GKG2 40-4A-0065H	40	73	640	373	6	221	136.5	240	357.5	317	49	97

L1min = Minimum submergence depth for motor without casing with continuous duty S1 (NPSHR permitting)

Lmin = Minimum submergence depth for motor without casing with intermittent duty S3 (NPSHR permitting)

Dimensions and weights

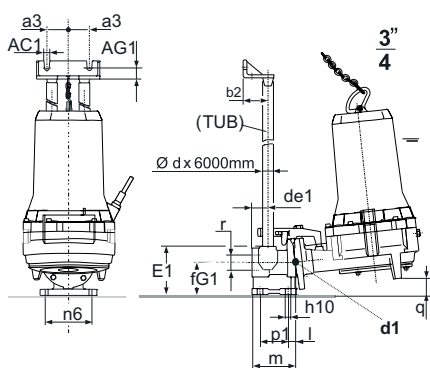

Duck foot coupling

TYPE	mm														
	a3	AC1	AG1	b2	d1	de1	E1	fG1	H1	h10	K1	n6	p1	q	y
SAK 40-G11/2-3/4	52.5	12	27	60	3/4"	40	120	80	21.5	14	113	115	70	37	G1 1/2"

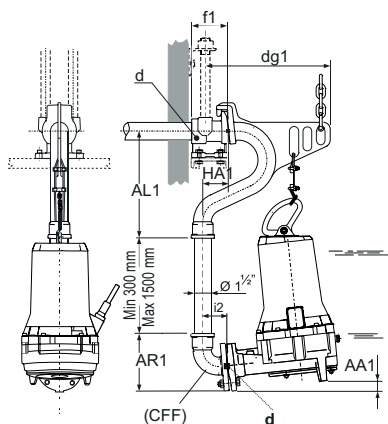

Duck foot coupling

TYPE	mm							
	AA1	AL1	AR1	d	dg1	f1	g3	HA1
SAK 40-G11/2A	29	315	165	G1 1/2"	403	107	76	76

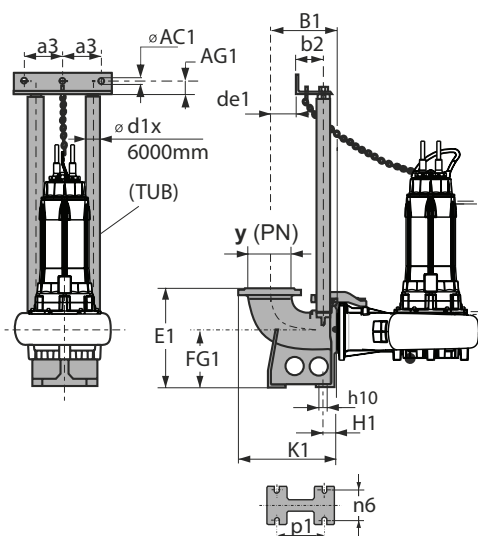

Duck foot coupling

TYPE	mm																
	a3	AC1	AG1	B1	b2	d1	de1	E1	fG1	H1	h10	K1	n6	p1	y	PN	
SAK 65-65-2	130	12.5	35	220	102	2"	40	280	160	47	18	312,5	110	156	65	16	
SAK 65-80-2	130	12.5	35	220	102	2"	40	280	160	47	18	320	110	156	80	16	
SAK 80-100-2	130	12.5	35	228	102	2"	48	320	180	47	18	338	110	156	100	16	
SAK 80-80-2	130	12.5	35	220	102	2"	40	320	180	47	18	320	110	156	80	16	
SAK 100-100-2	130	12.5	35	228	102	2"	48	430	280	49	18	338	194	186	100	16	
SAK 100-100-2A	130	12.5	35	228	102	2"	48	350	200	49	18	338	135	186	100	16	
SAK 150-150-2	158	12.5	35	260	102	2"	75	435	235	59	19	403	194	214	150	16	
SAK 150-200-3	157.5	12.5	35	385	117	3"	180	540	290	80	24	555	210	280	200	10	
SAK 200-250-3	157.5	12.5	35	425	117	3"	220	595	345	80	24	623	250	380	250	10	
SAK 200-250-3	157.5	12.5	35	425	117	3"	220	595	345	80	24	623	250	380	250	10	
SAK 250-300-3	157.5	12.5	35	450	117	3"	245	700	400	85	24	673	310	425	300	10	
SAK 300-350-3	157.5	12.5	35	500	117	3"	295	820	500	90	24	755	360	475	350	10	
SAK 350-400-3	157.5	12.5	35	525	117	3"	320	920	575	95	24	810	400	510	400	10	
SAK 250-300-3A	157.5	12.5	35	450	117	3"	245	700	400	85	24	673	310	425	300	10	
SAK 300-350-3A	157.5	12.5	35	500	117	3"	295	820	500	90	24	755	360	475	350	10	
SAK 350-400-3A	157.5	12.5	35	525	117	3"	320	920	575	95	24	810	400	510	400	10	

Dimensions and weights

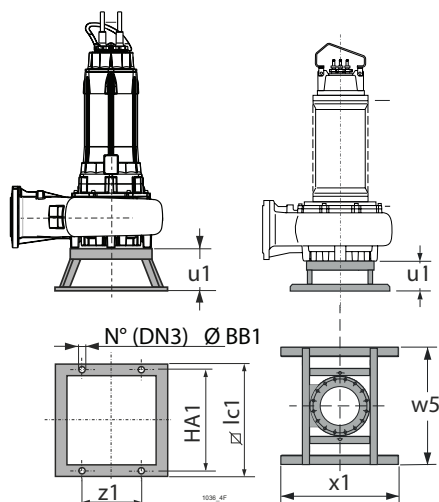

Submersible pump rest

TYPE	mm							
	BB1	DN3	HA1	lc1	u1	w5	x1	z1
APK 80	12	4	400	440	166	-	-	230
APK 100	14	4	600	650	180	-	-	350
APK 100A	14	4	600	650	180	-	-	350
APK 150	14	4	600	650	220	-	-	350
APK 150A	-	-	-	-	280	1000	1000	-
APK 250	14	4	600	650	220	-	-	350
APK 350	-	-	-	-	280	1000	1000	-

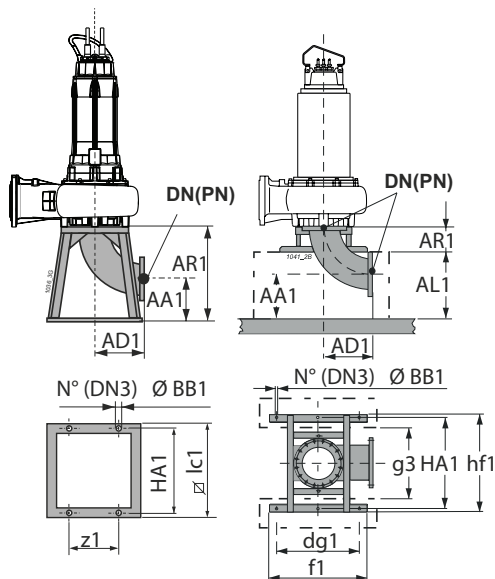

Dry chamber pump rest

TYPE	mm														
	DN	PN	AA1	AD1	AL1	AR1	BB1	dg1	DN3	f1	g3	HA1	hf1	lc1	z1
APCK 65	65	16	150	140	-	290	12	-	4	-	-	390	-	440	230
APCK 80	80	16	126	164	-	290	12	-	4	-	-	390	-	440	230
APCK 100	100	16	135	204	-	340	22	-	4	-	-	600	-	650	-
APCK 150	150	16	285	395	400	280	22	850	6	1000	740	935	1000	-	-
APCK 150A	150	16	205	395	-	600	22	-	4	-	-	600	-	650	-
APCK 200	200	10	290	310	-	600	22	-	4	-	-	600	-	650	-
APCK 250	250	10	215	385	-	600	22	-	4	-	-	600	-	650	-
APCK 250A	250	10	295	385	400	280	22	850	6	1000	740	935	1000	-	-
APCK 300	300	10	320	465	500	280	22	850	6	1000	740	935	1000	-	-
APCK 350	350	10	345	540	600	280	22	850	6	1000	740	935	1000	-	-

Dry chamber pump support

TYPE	mm										
	AB1	c1	dk1	fM1	HD1	hs1	i	M1	o	P1	s3
SOK80/N3	2	400	22	270	100	100	66	22	34	43	400
SOK100/N3	2	400	22	320	100	100	66	22	34	43	470
SOK150/N3	2	400	22	320	100	100	66	22	34	43	470
SOK150-200	3	530	22	335	160	270	100	22	40	85	-
SOK150-225	3	530	22	335	160	270	100	22	40	85	-
SOK150-250	3	530	22	335	160	270	100	22	40	85	-
SOK350-200	3	530	22	500	160	270	100	22	40	85	-
SOK350-225	3	530	22	500	160	270	100	22	40	85	-
SOK350-250	3	530	22	500	160	270	100	22	40	85	-
SOK 350-280	3	530	22	500	160	270	100	22	100	20	-
SOK 350-315	3	530	22	500	160	270	100	22	100	20	-

Installation with duck foot coupling

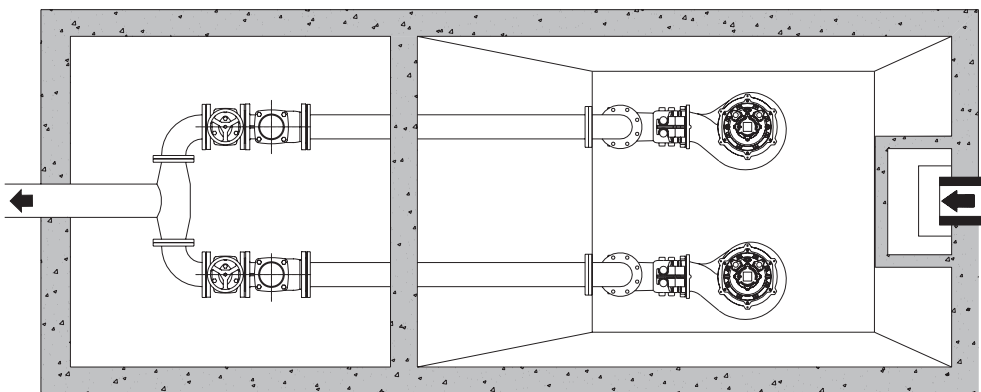
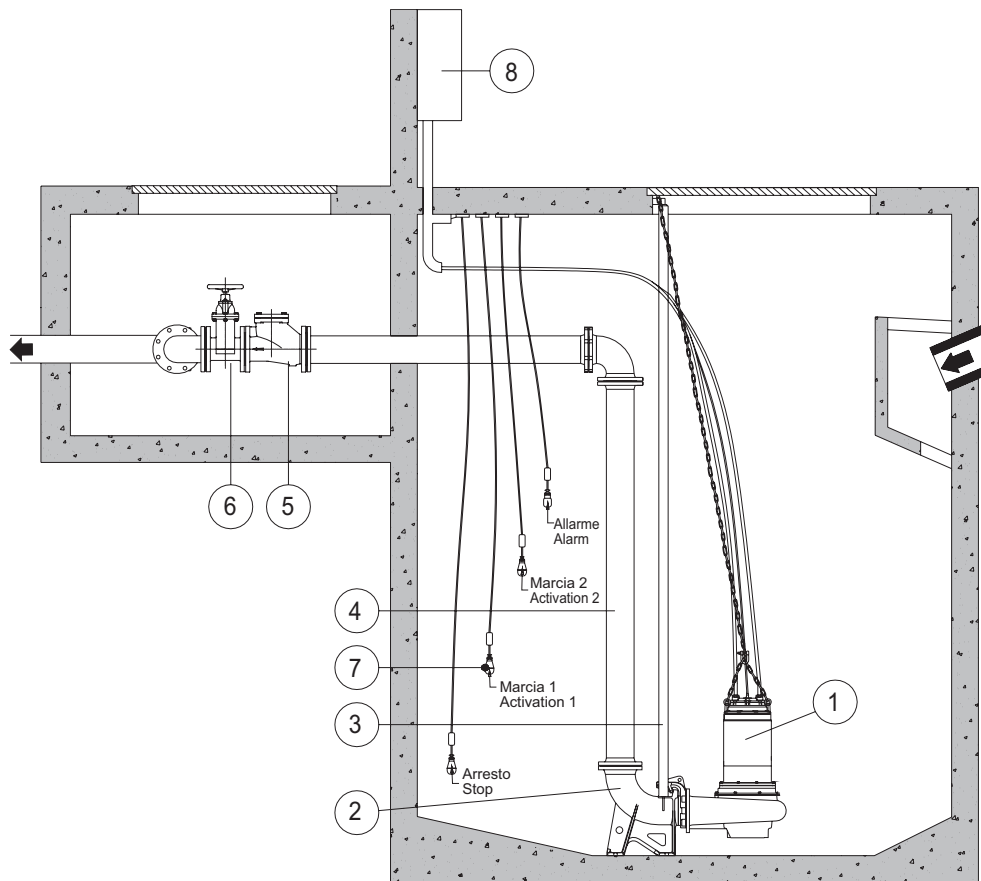

- 2 Submersible pump
- 3 Duck foot coupling
- 4 Guide pipes
- 5 Delivery pipe
- 6 Check valve
- 7 Gate valve
- 8 Level floats
- 9 Control box