

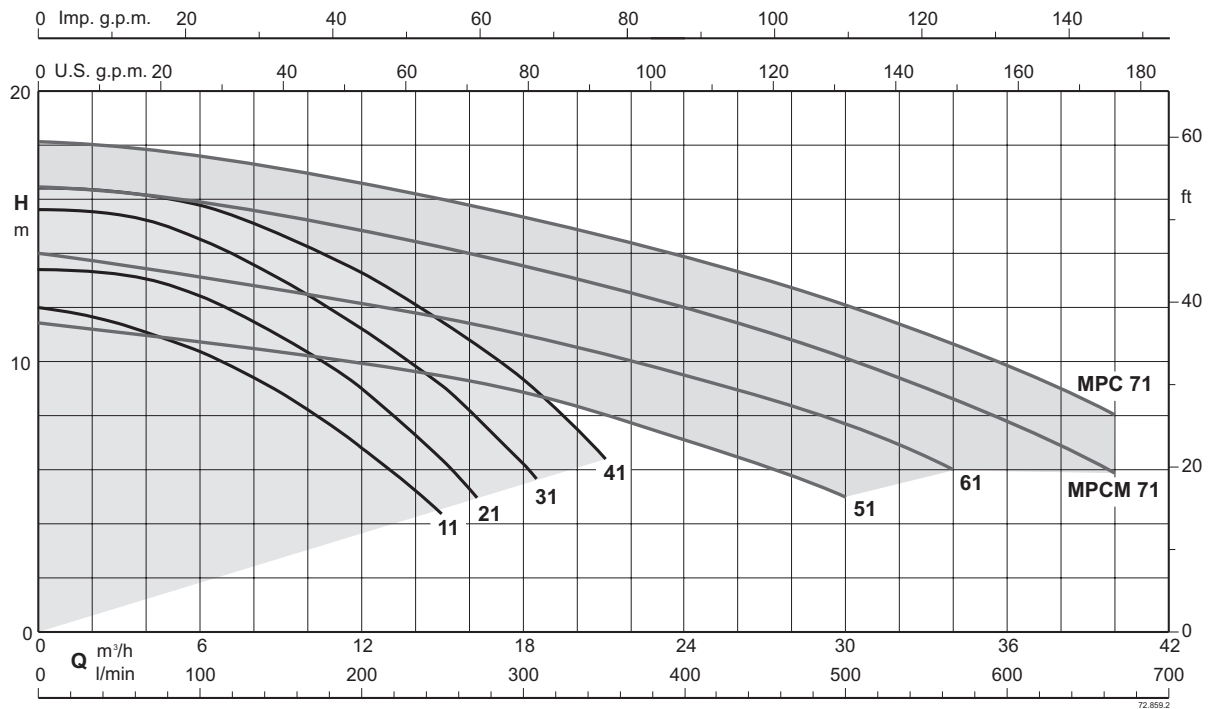

Coverage chart n ≈ 2800 rpm



## Self-priming swimming pool pumps with built-in strainer

### Construction

Self-priming swimming pool pumps with built-in strainer and a motor insulated from the pumped water.

The pump is made from high quality plastic materials, and is resistant to corrosion and sand erosion.

With stainless steel diffuser.

Includes a base-plate kit.

### Applications

For water circulation in swimming pool filtration systems.

For clean or slightly dirty water with solids in suspension.

### Operating conditions

Water temperature up to 60 °C.

Ambient temperature up to 40° C.

Maximum permissible pressure in the pump casing 2,5 bar.

Continuous duty (S3 60% for single-phase pump to 1,5-1,8 kW).

### Certification mark for MPCM



### Motor

2-pole induction motor, 50 Hz ( $n \approx 2800$  1/min).

**MPC:** three-phase 230/400 V  $\pm$  10%,

**MPCM:** single-phase 230 V  $\pm$  10%, with thermal protector. Capacitor inside the terminal box.

Insulation class F.

Protection IP X4.

**IE2 efficiency class for single-phase motors up to 1,1 kW.**

**IE3 efficiency class for three-phase motors (IE2 up to 0,65 kW).**

Constructed in accordance with EN 60034-1; EN 60034-30-1.

EN 60335-1, EN 60335-2-41.

### Special features on request

Other voltages.

Frequency 60 Hz (as per 60 Hz data sheet).

### Designation

Example: MPCM 21/A

MPC = Series

M = Single-phase version (no indication: three-phase)

21 = Pump type

/A = It refers to a revision

### Materials

Components	Materials
Pump casing	Noryl PPO-GF30
Diffuser cover	Noryl PPO-GF30
Impeller	Noryl PPO-GF30
Strainer cover	Lexan
Strainer basket	Polypropylene
Diffuser funnel and wear-ring	Stainless Steel 1.4401 EN 10088 (AISI 316)
Mechanical seal	Carbon - Ceramic - FPM

## Performance n ≈ 2800 rpm

## Three-phase

					Q = Flow								
					m³/h	0	3	6	9	12	15	18	21
Model	230V	400V	P2		l/min		50	100	150	200	250	300	350
	A		kW	HP	H (m) = Total head								
MPC 11	2,8	1,6	0,37	0,5		11,9	11,4	10,3	8,9	6,8	4,2	-	-
MPC 21/A	3	1,7	0,55	0,75		13,4	13,3	12,4	10,9	9	6,3	-	-
MPC 31/B	3,7	2,2	0,75	1		15,6	15,5	14,5	13	11,2	9,1	6,2	-
MPC 41/A	4,6	2,7	1,1	1,5		16,4	16,2	15,8	14,7	13,3	11,4	9,3	6,4

## Single-phase

					Q = Flow								
					m³/h	0	3	6	9	12	15	18	21
Model	230V	P2		P1	l/min		50	100	150	200	250	300	350
	A	kW	HP	kW	H (m) = Total head								
MPCM 11	3,3	0,37	0,5	0,57		11,9	11,4	10,3	8,9	6,8	4,2	-	-
MPCM 21/A	4,5	0,55	0,75	1		13,4	13,3	12,4	10,9	9	6,3	-	-
MPCM 31/A	5,4	0,75	1	1,2		15,6	15,5	14,5	13	11,2	9,1	6,2	-
MPCM 41	7	1,1	1,5	1,6		16,4	16,2	15,8	14,7	13,3	11,4	9,3	6,4

## Three-phase

					Q = Flow											
					m³/h	0	3	9	15	18	21	24	27	30	34	40
Model	230V	400V	P2		l/min	0	50	150	250	300	350	400	450	500	567	667
	A		kW	HP			H (m) = Total head									
MPC 51/A	4,6	2,7	1,1	1,5		11,5	11	10,5	9,5	9	8	7	6	5	-	-
MPC 61/A	6,2	3,6	1,5	2		14	13,5	12,5	11,5	11	10,5	9,5	8,5	7,5	6	-
MPC 71/B	9,2	5,3	2,2	3		18,2	18	17	16	15,5	14,5	14	13	12	10,5	8

## Single-phase

					Q = Flow											
					m³/h	0	3	9	15	18	21	24	27	30	34	40
Model	230V	P2		P1	l/min	0	50	150	250	300	350	400	450	500	567	667
	A	kW	HP	kW	H (m) = Total head											
MPCM 51	7	1,1	1,5	1,6		11,5	11	10,5	9,5	9	8	7	6	5	-	-
MPCM 61	9,2	1,5	2	2		14	13,5	12,5	11,5	11	10,5	9,5	8,5	7,5	6	-
MPCM 71/B	11,2	1,8	2,5	2,5		16,4	15,9	14,9	14	13,4	12,7	12,1	11,3	10,2	8,5	5,8

P1: Maximum power input.

P2: Rated motor power output.

H: Total head in m

Tolerances according to UNI EN ISO 9906:2012

## Self-Priming Capability with the pump located above the water level

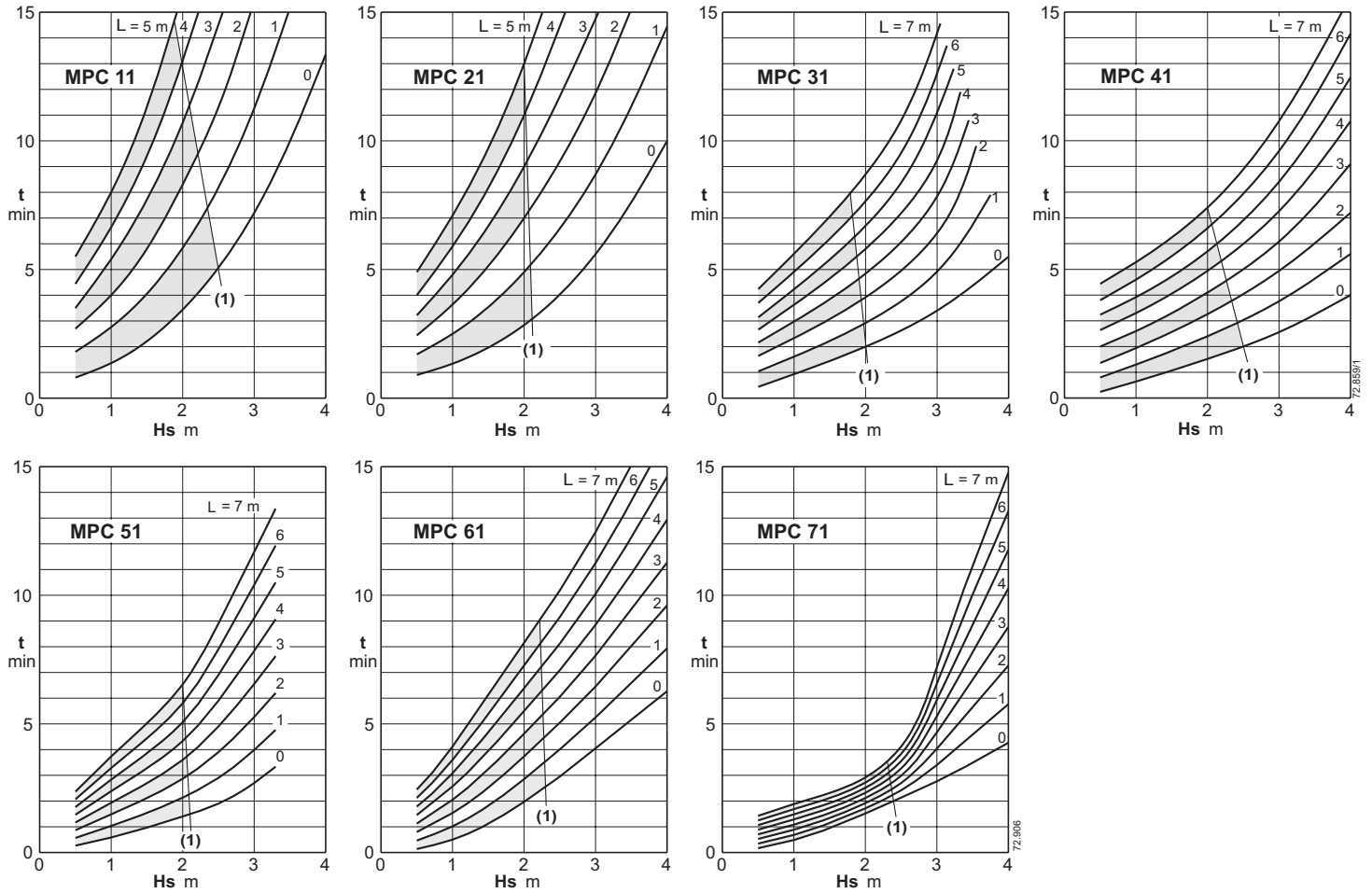

(1) Application limit for automatic self-repriming at each start-up, without check valve.  
 L (m) Horizontal length of suction pipe above the water level.  
 Hs (m) Suction lift.  
 t (min) Self-priming time.

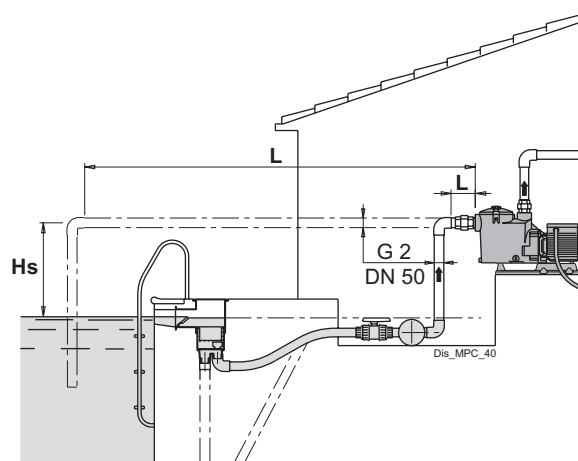

## Dimensions and weights

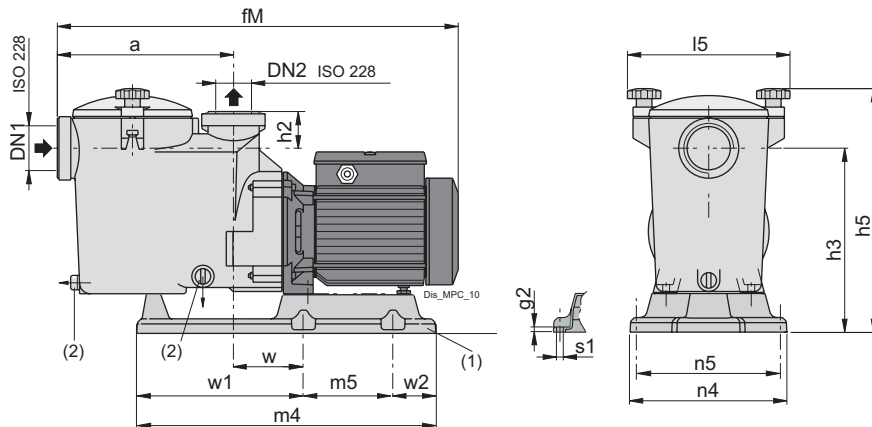

TYPE	ISO 228		mm															kg
	DN1	DN2	a	fM	g2	h2	h3	h5	l5	m4	m5	n4	n5	s1	w	w1	w2	Weight
MPC 11	G2	G1 1/2	235	504	7	50	243	323	215	410	123	215	197	9	100	228.5	58.5	9.4
MPC 21/A	G2	G1 1/2	235	536	7	50	243	323	215	410	123	215	197	9	100	228.5	58.5	10.8
MPC 31/B	G2	G1 1/2	235	536	7	50	243	323	215	410	123	215	197	9	100	228.5	58.5	12.7

TYPE	ISO 228		mm															kg
	DN1	DN2	a	fM	g2	h2	h3	h5	l5	m4	m5	n4	n5	s1	w	w1	w2	Weight
MPCM 11	G2	G1 1/2	235	504	7	50	243	323	215	410	123	215	197	9	100	228.5	58.5	9.4
MPCM 21/A	G2	G1 1/2	235	536	7	50	243	323	215	410	123	215	197	9	100	228.5	58.5	11.7
MPCM 31/A	G2	G1 1/2	235	536	7	50	243	323	215	410	123	215	197	9	100	228.5	58.5	12.8

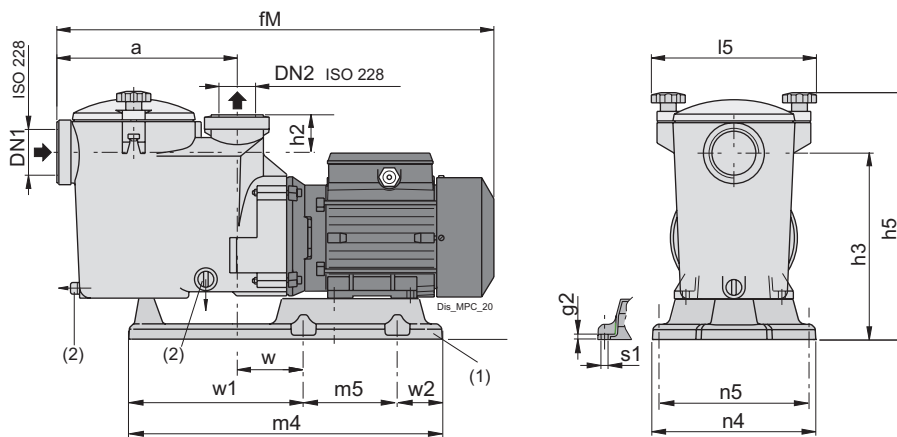

TYPE	ISO 228		mm															kg
	DN1	DN2	a	fM	g2	h2	h3	h5	l5	m4	m5	n4	n5	s1	w	w1	w2	Weight
MPC 41/A	G2	G1 1/2	235	584	7	50	243	323	215	410	123	215	197	9	100	228.5	58.5	17

TYPE	ISO 228		mm															kg
	DN1	DN2	a	fM	g2	h2	h3	h5	l5	m4	m5	n4	n5	s1	w	w1	w2	Weight
MPCM 41	G2	G1 1/2	235	584	7	50	243	323	215	410	123	215	197	9	100	228.5	58.5	17.1

(1): Pump support base kit  
 (2): Draining

## Dimensions and weights

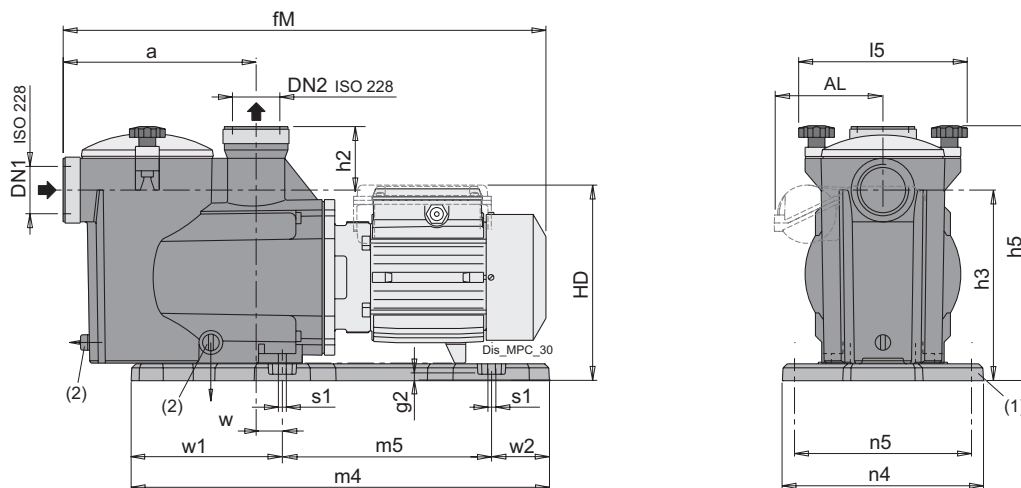

TYPE	ISO 228		mm															kg	
	DN1	DN2	a	fM	g2	h2	h3	h5	HD	l5	m4	m5	n4	n5	s1	w	w1	w2	Weight
MPC 51/A	G2	G2	235	600	8	80	243	323	260	215	520	260	250	220	14	30	188	72	18.6
MPC 61/A	G2	G2	235	600	8	80	243	323	260	215	520	260	250	220	14	30	188	72	20
MPC 71/B	G2	G2	235	640	8	80	243	323	260	215	520	260	250	220	14	30	188	72	23.2

TYPE	ISO 228		mm																	kg
	DN1	DN2	a	AL	fM	g2	h2	h3	h5	HD	l5	m4	m5	n4	n5	s1	w	w1	w2	Weight
MPCM 51	G2	G2	235	-	600	8	80	243	323	260	215	520	260	250	220	14	30	188	72	18.8
MPCM 61	G2	G2	235	-	600	8	80	243	323	260	215	520	260	250	220	14	30	188	72	20.7
MPCM 71/B	G2	G2	235	131	640	8	80	243	323	260	215	520	260	250	220	14	30	188	72	23.7

(1): Pump support base kit  
 (2): Draining