

NCE H2

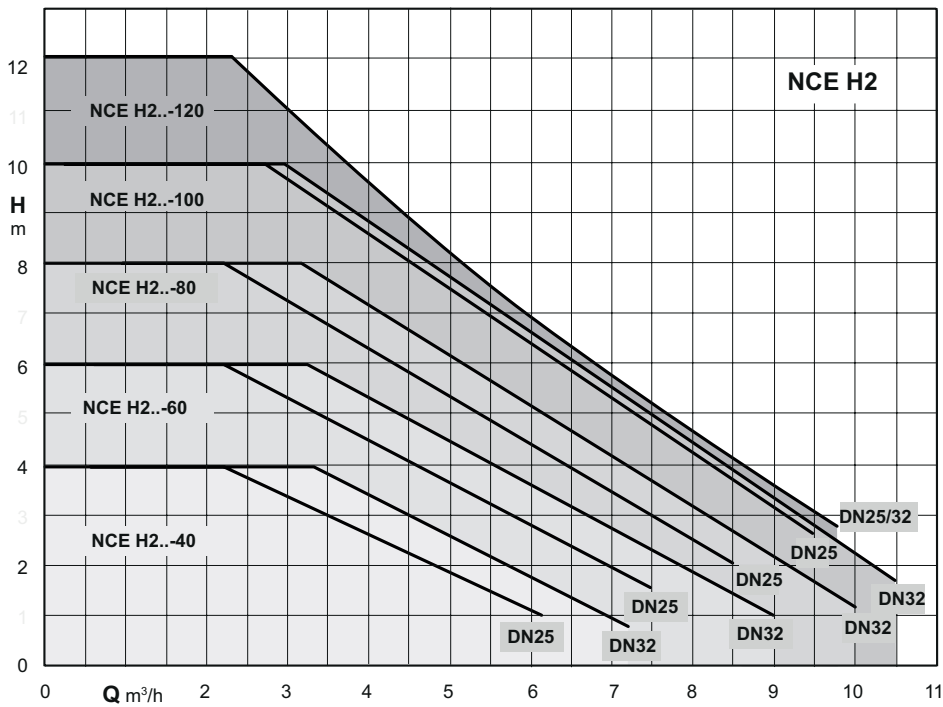

Coverage chart



Energy saving Circulating Pumps with frequency converter

Construction

Energy saving variable speed circulating pump driven by a permanent magnet synchronous motor (pm) controlled by on board inverter.

Standard with steel unions with cataphoresis treatment.

Applications

The energy-efficient circulation pump is designed for water circulation in heating systems.

Underfloor heating systems

Single-pipe systems

Two-pipe systems

Pumping liquid:

Clean, non-aggressive and non-explosive liquids, not containing solid particles, fibers or mineral/vegetable oil

In heating systems, water must meet the requirements of accepted standards of water quality in heating systems.

Operating conditions

- Liquid temperature from -10 °C to +110 °C
- Ambient temperature from 0 °C to +40 °C
- Maximum permissible working pressure: 10 bar
- Storage: -10°C/+50°C max. relative humidity 95% at 40 °C
- Certifications: in conformity with CE requirements
- Sound pressure ≤ 45 dB (A).
- Max. quantity of ethylene glycol: 40%
- EMC according to: EN 55014-1, EN 55014-2, EN 61000-3-2, EN 61000-3-3.
- Connections: threaded ports ISO 228: G 1 1/2, G 2.
- Flanged connection DN 32 PN 10
- The energy efficiency index of circulators is $IEE \leq 0.23$.
- The benchmark for most efficient circulators is $EEL \leq 0,20$.

Motor

- Synchronous motor with permanent magnet.
- Motor: variable speed
- Standard voltage: single-phase 230 V (-10%;+6%)
- Frequency: 50-60 Hz
- Protection: IP 44
- Insulation class: F
- Overload protection (integrated).
- Cable: phases and neutral.
- Constructed in accordance with: EN 60335-1, EN 60335-2-51.

Designation

NCE H2 32 F - 100 / 180

NCE = Series

H2 = Version

32 = DN ports in mm

F = Flanged connection

100 = Max. head in dm

180 = connection size mm

Materials

Component	Material
Pump casing	Cast iron with cataphoresis coating
Impeller	Composite PES
Shaft	Ceramic
Ball bearings	Ceramic
Thrust bearing	Graphite carbon
Rotor	Stainless steel jacket
Electronic card	..

Operating modes



Automatic mode
(factory setting):

In this mode the pump automatically sets the operating pressure, depending on the hydraulic system. This mode is recommended in most systems.



Proportional pressure mode:

The circulator changes the pressure proportionally to the current flow. The pressure value can be adjusted on three curves.



Constant pressure mode:

The circulator maintains the pressure constant when the reference flow changes. The pressure value can be adjusted on three curves.

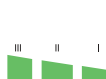

Fixed speed mode:

The circulator works with constant curve and the curve could be changed over three curves.



Night mode:

The pump is changed to an automatic deceleration curve at night, so that it runs at low performance and low energy consumption.

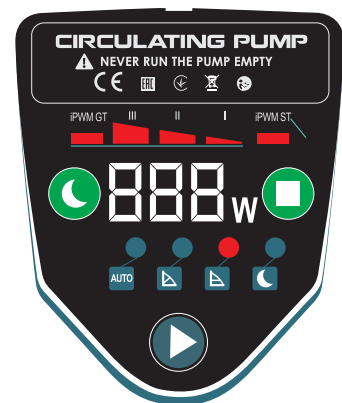

The circulator can operate in:

- automatic mode
- proportional pressure mode
- constant pressure mode
- fixed speed mode
- night mode

Characteristic curves

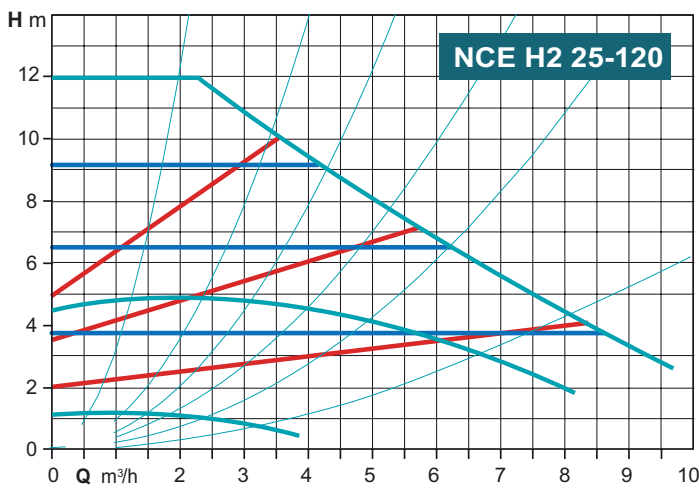
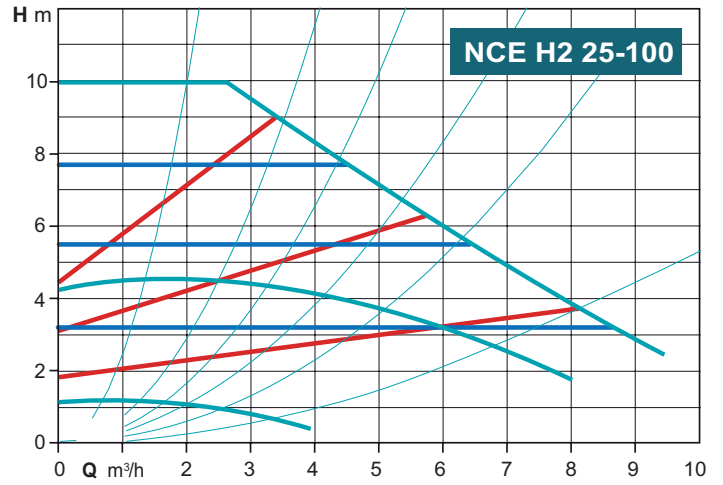
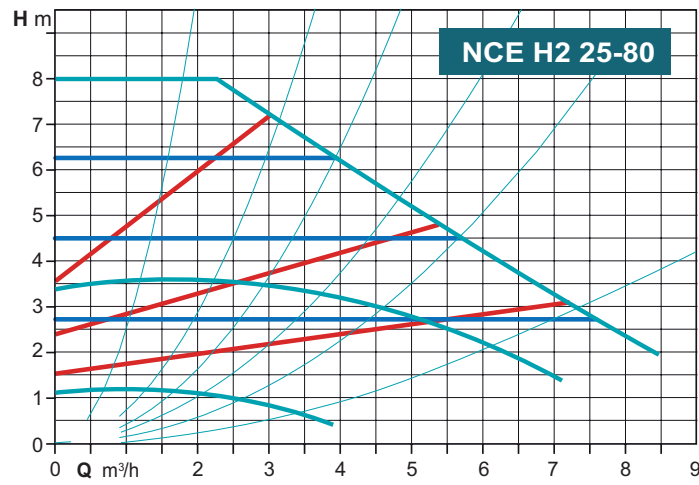
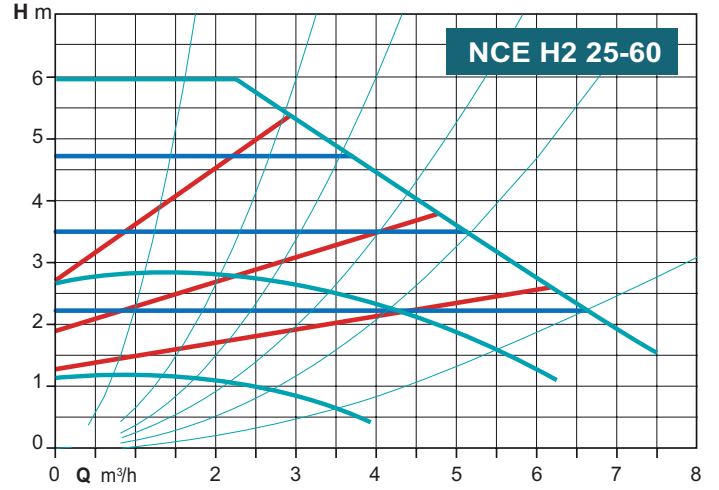
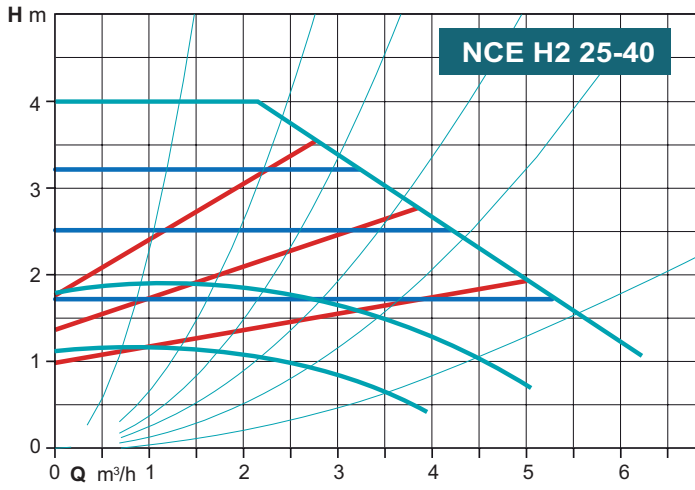

■ Proportional pressure ■ Constant pressure ■ Constant speed

Characteristic curves

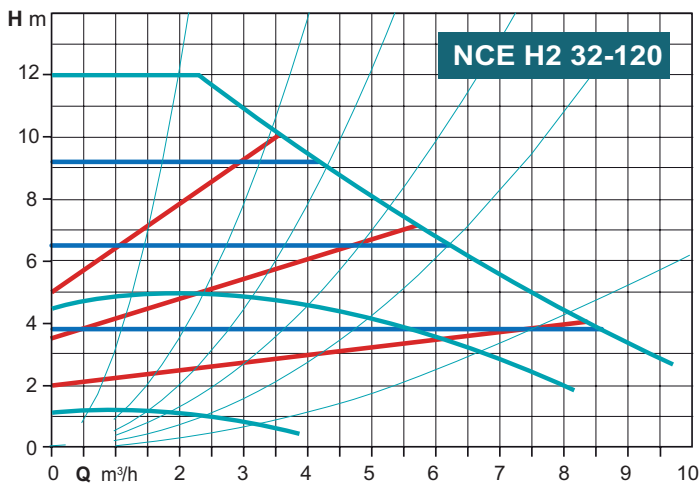
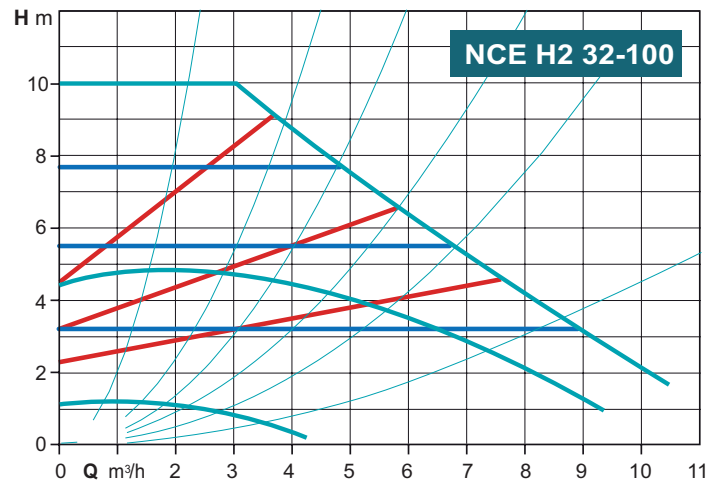
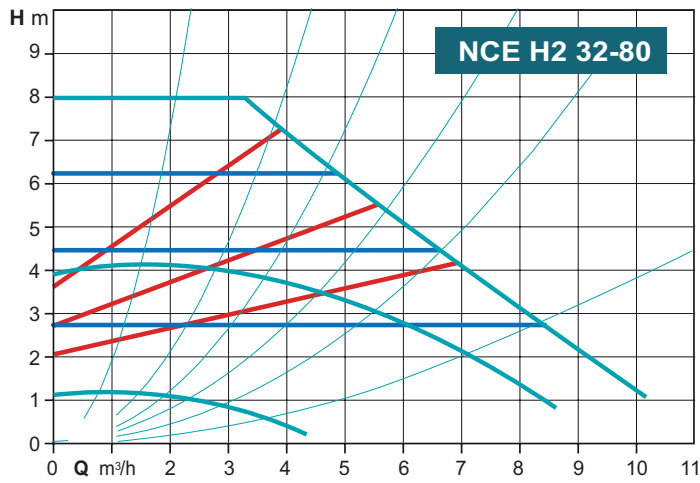
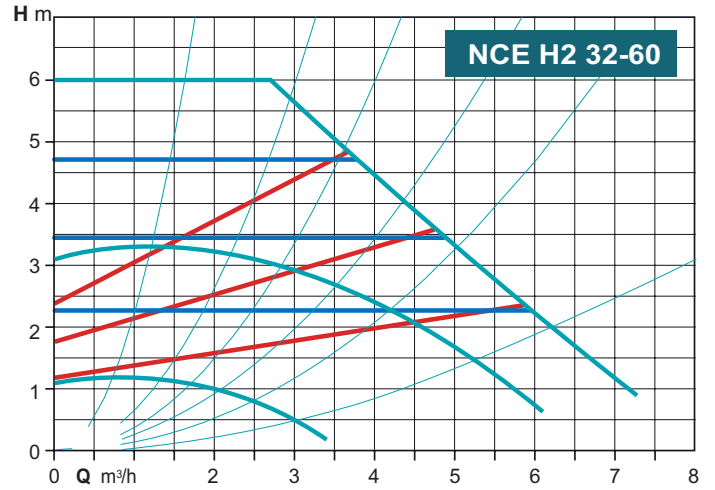
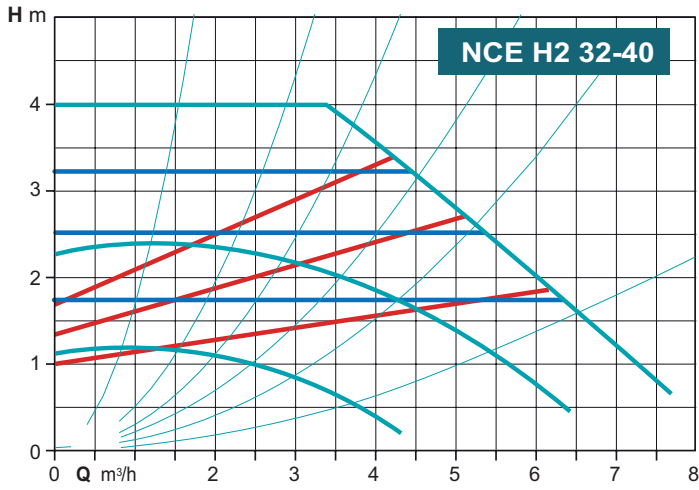

■ Proportional pressure ■ Constant pressure ■ Constant speed

Characteristic curves

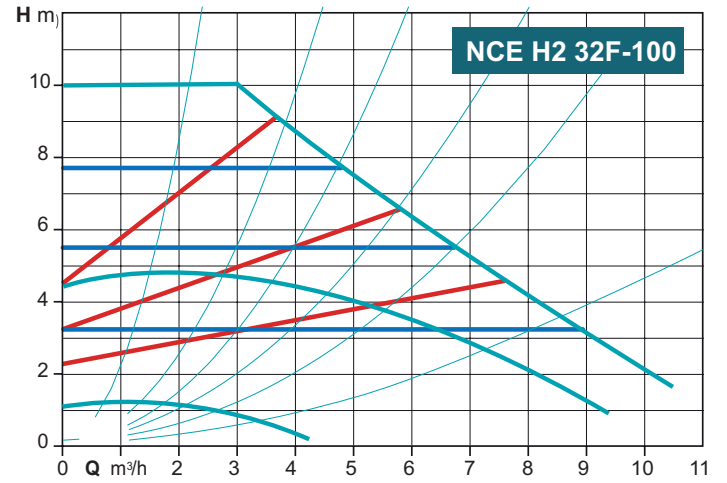
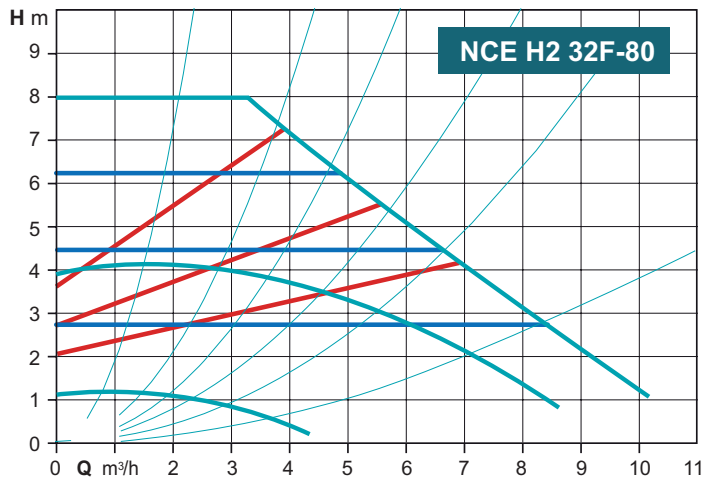
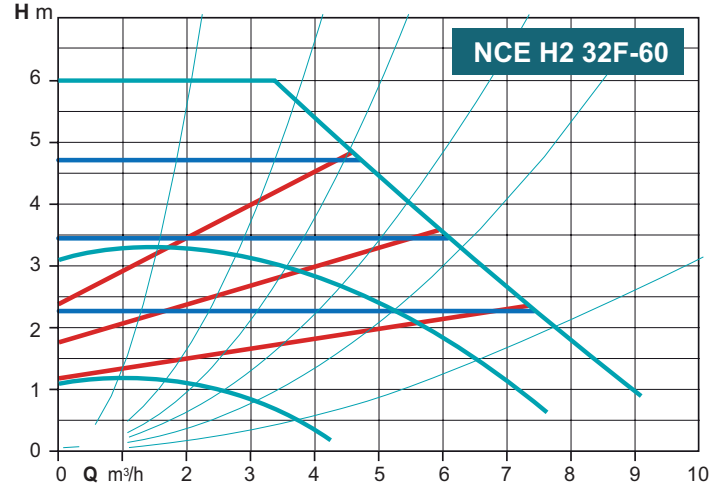
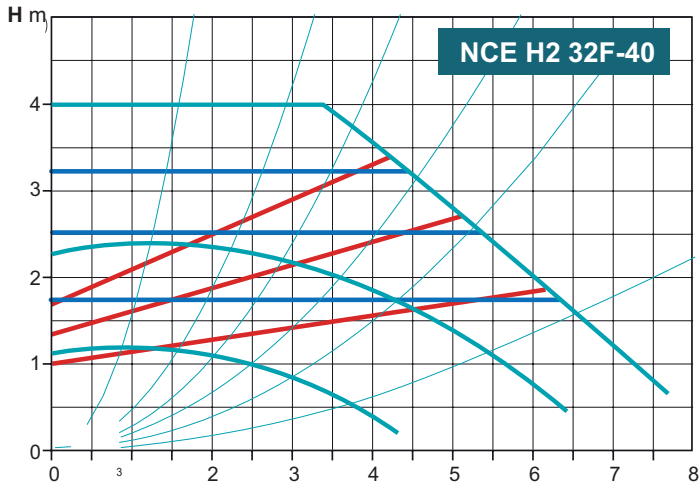

■ Proportional pressure ■ Constant pressure ■ Constant speed

Dimensions and weights

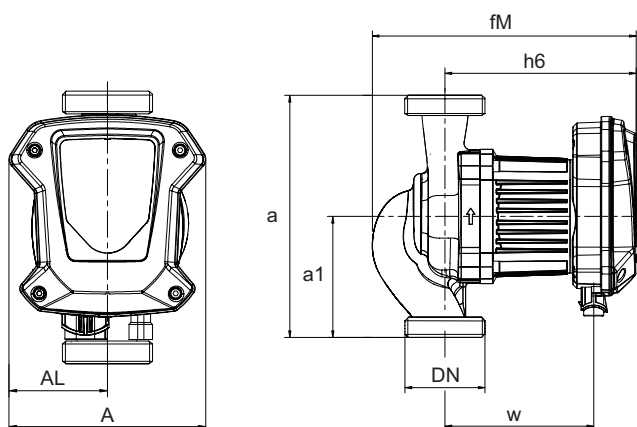

Unions

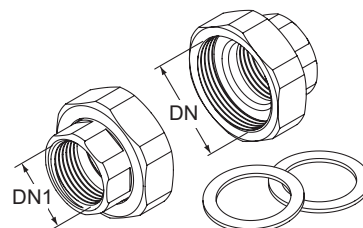

TYPE	DN	DN1
KIT G 1 1/2 - G 1 (NCE . 25..)	G 1 1/2	G 1
KIT G 2 - G 1 1/4 (NCE . 32..)	G 2	G 1 1/4

TYPE	DN	H max	Q max	1~ 230 V	P1	P1	mm	mm	mm	mm	mm	mm	mm	kg
		m	m ³ /h	A max	W min	W max								
NCE H2 25-40/180	G 1 1/2	4	6.2	0.23	9	60	180	90	196	130	65	142	110.5	4
NCE H2 32-40/180	G 2	4	7.7	0.3	9	78	180	90	196	130	65	142	110.5	4.4
NCE H2 25-60/180	G 1 1/2	6	7.5	0.41	9	105	180	90	196	130	65	142	110.5	4
NCE H2 32-60/180	G 2	6	9.1	0.46	9	120	180	90	196	130	65	142	110.5	4.4
NCE H2 25-80/180	G 1 1/2	8	8.5	0.58	9	150	180	90	196	130	65	142	110.5	4
NCE H2 32-80/180	G 2	8	10.1	0.65	9	168	180	90	196	130	65	142	110.5	4.4
NCE H2 25-100/180	G 1 1/2	10	9.4	0.78	9	200	180	90	196	130	65	142	110.5	4
NCE H2 32-100/180	G 2	10	10.5	0.76	9	200	180	90	196	130	65	142	110.5	4.4
NCE H2 25-120/180	G 1 1/2	12	9.7	0.86	9	220	180	90	196	130	65	142	110.5	4
NCE H2 32-120/180	G 2	12	9.7	0.84	9	220	180	90	196	130	65	142	110.5	4.4

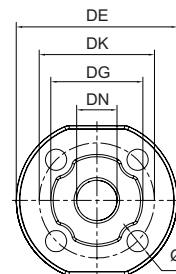
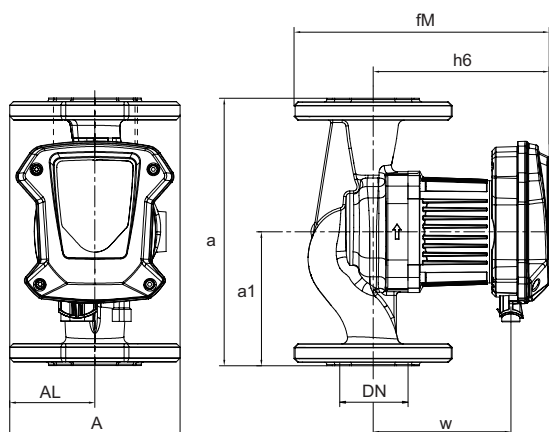

mm					
DN	DE	DK	DG	Holes	
				N°	Ø
32	140	100	80	4	19

TYPE	DN	H max	Q max	1~ 230 V	P1	P1	mm	mm	mm	mm	mm	mm	mm	kg
		m	m ³ /h	A max	W min	W max								
NCE H2 32F-40/220	32	4	7.7	0.3	9	78	220	110	210	140	70	145	113	7.3
NCE H2 32F-60/220	32	6	9.1	0.46	9	120	220	110	210	140	70	145	113	7.3
NCE H2 32F-80/220	32	8	10.1	0.65	9	168	220	110	210	140	70	145	113	7.3
NCE H2 32F-100/220	32	10	10.5	0.79	9	200	220	110	210	140	70	145	113	7.3

Examples of installations

