

NM, NMD

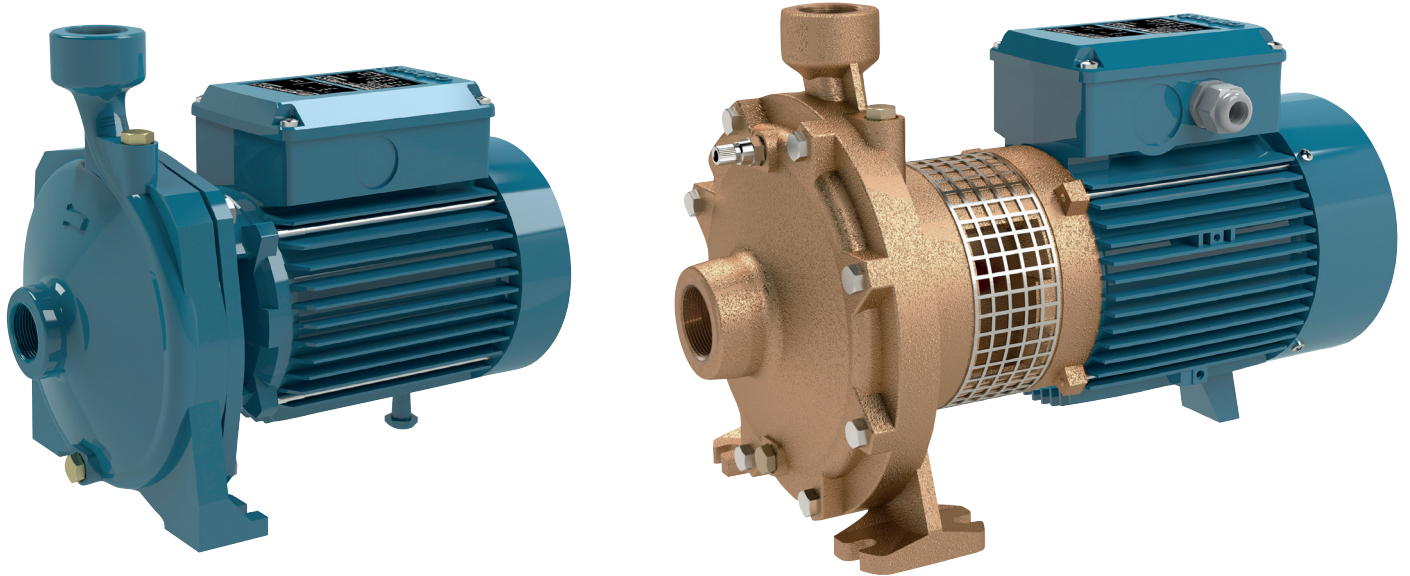

Coverage chart n ≈ 2900 rpm

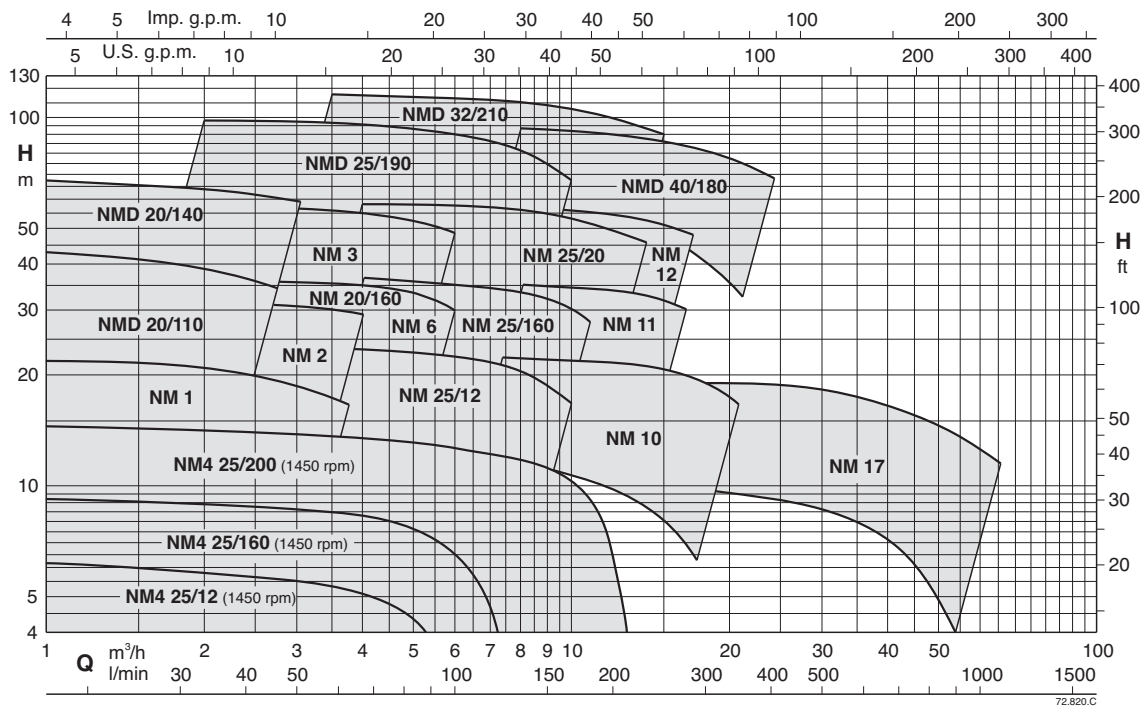

Close coupled centrifugal pumps with screwed connections

Construction

Close-coupled, centrifugal pumps; electric motor with extended shaft directly connected to the pump.

NM, NM4: single-impeller

NMD: with two back-to-back impellers (with axial thrust balancing).

Rated speed of rotation (50 Hz):

NM, NMD \approx 2900 rpm.

NM4 \approx 1450 rpm.

Connections: threaded ports ISO 228/1 (BS 2779).

NM, NMD: version with pump casing and lantern bracket in cast iron.

BNM, BNMD: version with pump casing and lantern bracket in bronze.

The pumps are supplied fully painted.

Applications

For clean liquids without abrasives, which are non-aggressive for the pump materials (solids content up to 0.2%).

For water supply.

For heating, air-conditioning, cooling and circulation plants.

For civil and industrial applications.

For irrigation.

Operating conditions

Liquid temperature from -10 °C to +90 °C.

Ambient temperature up to 40° C.

Total suction lift up to 7 m.

Maximum permissible working pressure up to 10 bar (16 bar for pumps NMD 25/190; NMD 32/210; NMD 40/180).

Continuous duty (S3 60% for single-phase pump to 1,5-1,8 kW).

Motor

2-pole induction motor, 50 Hz ($n \approx$ 2900 rpm).

NM, NMD: three-phase 230/400 V \pm 10% up to 3 kW;
400/690 V \pm 10% from 4 to 9,2 kW;

NMM, NMDM: single-phase 230 V \pm 10%, with thermal protector.

4-pole induction motor, 50 Hz ($n \approx$ 1450 rpm).

NM4: three-phase 230/400 V \pm 10%.

Insulation class F.

Protection IP54

Motor suitable for operation with frequency converter from 0,37 kW for NM4 and from 1,1 kW for NM,NMD.

IE2 efficiency class for single-phase motors up to 1,1 kW.

IE3 efficiency class for three-phase motors (IE2 up to 0,65 kW).

Constructed in accordance with EN 60034-1, EN 60034-30-1,
EN 60335-1, EN 60335-2-41.

Special features on request

Other voltages.

Frequency 60 Hz (as per 60 Hz data sheet).

IP protection: IP55

Special mechanical seal

Higher or lower liquid or ambient temperatures.

Motor suitable for operation with frequency converter up to 0,33 kW for NM4 and up to 0,75 kW for NM,NMD.

Designation

Example: BNMD(4)M 20/140A/B

B = Bronze version (no indication: the pump is in the Cast Iron version)

NM = Series

D = Double impeller

4 = 4-pole version (without indication, 2-pole version)

M = Single-phase version (no indication: three-phase)

20 = Delivery port diameter in mm

140 = Nominal impeller diameter

A = Impeller size

/B = It refers to a revision

The electropumps NM, B-NM series comply with the European Regulation no. 547/2012.

Materials

Components	NM, NMD, NM4	BNM, BNMD, BNM4
Pump casing	Cast iron GJL 200 EN 1561	Bronze CC480K EN 1982
Lantern bracket	Cast iron GJL 200 EN 1561	Bronze CC480K EN 1982
Impeller	Brass CW617N EN 12167	Brass CW617N EN 12167
Impeller NM17	Cast iron GJL 200 EN 1561	Bronze CC480K EN 1982
Shaft	Chrome-nickel steel 1.4305 EN 10088 (AISI 303)	Stainless Steel 1.4401 EN 10088 (AISI 316)
	Steel 1.4104 EN 10088 AISI 430F (NM 1, 2, 6, 25/12, NMD 20/110)	Stainless Steel 1.4401 EN 10088 (AISI 316)
Shaft NM 6	Stainless Steel 1.4104 EN 10088 (AISI 430F)	-
Mechanical seal	Carbon - Ceramic - NBR	Carbon - Ceramic - NBR

Coverage chart n ≈ 2900 rpm

Three-phase

					Q = Flow															
					m³/h	0	1	1,2	1,5	1,89	2,4	3	3,6	4,2	4,8	5,4	6	6,6	7,5	8,4
Model	230V	400V	P2		l/min	16,6	20	25	31,5	40	50	60	70	80	90	100	110	125	140	
	A		kW	HP	H (m) = Total head															
NM 1/A	2,4	1,4	0,37	0,5		22,7	22	21,6	21,3	20,9	20,3	19,4	18,1	16,3	-	-	-	-	-	-
NM 2/B/A	3	1,7	0,55	0,75		26,5	27	26,5	26	25,5	25	24	23	22	20	-	-	-	-	-
NM 2/S/A	3	1,7	0,55	0,75		33	31	30,5	30	29	27,5	25,5	23,5	20	16	-	-	-	-	-
NM 2/A/B	3,7	2,2	0,75	1		33,8	33,5	33	32,5	32	31,5	30,5	29,5	28,5	27	26	24	-	-	-
NM 3/C/A	4,6	2,7	1,1	1,5		38	-	37,5	37,5	37	36,5	36	35	34	32	30,5	28,5	-	-	-
NM 3/B/A	7,5	4,3	1,5	2		48	-	47	47	46,5	46	45,5	45	44	43	41,5	40	37,5	33	26
NM 3/A/B	9,2	5,3	2,2	3		56,8	-	56	55,5	55,5	55	54,5	53,5	52,5	51,5	50	48	46	42	36
NM 6/B	3,8	2,2	0,75	1		31,8	-	-	-	30,5	30	29,5	28,5	27,5	26,5	25,5	24	22	18	-
NM 6/A	4,6	2,7	1,1	1,5		36	-	-	-	35,5	35,2	34,7	34	33	32	30,5	29	27	23,5	19

Single-phase

					Q = Flow															
					m³/h	0	1	1,2	1,5	1,89	2,4	3	3,6	4,2	4,8	5,4	6	6,6	7,5	8,4
Model	230V	P2		P1	l/min	16,6	20	25	31,5	40	50	60	70	80	90	100	110	125	140	
	A	kW	HP	kW	H (m) = Total head															
NMM 1/A	3	0,37	0,5	0,57		22,7	22	21,6	21,3	20,9	20,3	19,4	18,1	16,3	-	-	-	-	-	-
NMM 2/B/A	4,5	0,55	0,75	0,78		26,5	27	26,5	26	25,5	25	24	23	22	20	-	-	-	-	-
NMM 2/S/A	4,5	0,55	0,75	0,78		33	31	30,5	30	29	27,5	25,5	23,5	20	16	-	-	-	-	-
NMM 2/A/A	5,7	0,75	1	1,01		33,8	33,5	33	32,5	32	31,5	30,5	29,5	28,5	27	26	24	-	-	-
NMM 3/C	7,4	1,1	1,5	1,44		38	-	37,5	37,5	37	36,5	36	35	34	32	-	-	-	-	-
NMM 3/B	9,2	1,5	2	2		42,5	-	42	42	41,5	41	40,5	40	39	37	35	32	-	-	-
NMM 3/A/A	11,2	1,8	2,5	2,5		48,8	-	47,5	47,5	47	46,5	46	45,5	44,5	43,5	42	40,5	38	33,5	26,5
NMM 6/B	5,7	0,75	1	1,01		31,8	-	-	-	30,5	30	29,5	28,5	27,5	26,5	25,5	24	22	18	-
NMM 6/A	7	1,1	1,5	1,44		36	-	-	-	35,5	35,2	34,7	34	33	32	30,5	29	27	23,5	19

Three-phase

					Q = Flow														
					m³/h	0	1	1,2	1,5	1,89	2,4	3	3,6	4,2	4,8	5,4	6	6,6	
Model	230V	400V	P2		l/min	16,6	20	25	31,5	40	50	60	70	80	90	100	110		
	A		kW	HP	H (m) = Total head														
BNMD	NMD 20/110B/A	2,3	1,3	0,45	0,6		35,5	33	32	31	29	26,5	23	18	-	-	-	-	-
BNMD	NMD 20/110Z/A	3	1,7	0,55	0,75		39,5	37	36	35	33	30,5	27,5	23	18	-	-	-	-
BNMD	NMD 20/110A/B	3,7	2,2	0,75	1		45,6	43	42	40,5	39	36,5	33	29	25	-	-	-	-
BNMD	NMD 20/140B/A	4,6	2,7	1,1	1,5		54	53	52,5	52	51	50	48	46	43,5	40	-	-	-
BNMD	NMD 20/140A/A	7,5	4,3	1,5	2		68	67	66,5	66	64,5	63	61,5	59	57	53,5	50	46	-
BNM	NM 20/160BE	4	2,3	0,75	1		31,6	-	-	-	30,5	30	29,5	28,5	27,5	26,5	25,5	24	22
BNM	NM 20/160A/A	4,6	2,7	1,1	1,5		37	-	-	-	36	35,5	35	34,5	33,5	32	30,5	29	27

Single-phase

					Q = Flow														
					m³/h	0	1	1,2	1,5	1,89	2,4	3	3,6	4,2	4,8	5,4	6	6,6	
Model	230V	P2		P1	l/min	16,6	20	25	31,5	40	50	60	70	80	90	100	110		
	A	kW	HP	kW	H (m) = Total head														
BNMDM	NMDM 20/110B/A	3,6	0,45	0,6	0,67		35,5	33	32	31	29	26,5	23	18	-	-	-	-	-
BNMDM	NMDM 20/110Z/A	4,5	0,55	0,75	0,78		39,5	37	36	35	33	30,5	27,5	23	18	-	-	-	-
BNMDM	NMDM 20/110A/A	5,7	0,75	1	1,01		45,5	43	42	40,5	39	36,5	33	29	25	-	-	-	-
BNMDM	NMDM 20/140BE	7,4	1,1	1,5	1,44		52,5	52	51,5	51	50	48,5	47	45	-	-	-	-	-
BNMDM	NMDM 20/140AE	9,2	1,5	2	2		58	57,5	57	56,5	55,5	54	51,5	49	46	43	40	36	-
BNMM	NMM 20/160B	5,8	0,75	1	1,01		31,6	-	-	-	30,5	30	29,5	28,5	27,5	26,5	25,5	24	22
BNMM	NMM 20/160A	7,4	1,1	1,5	1,44		37	-	-	-	36	35,5	35	34,5	33,5	32	30,5	29	27

Performance n ≈ 1450 rpm

Three-phase

					Q = Flow																				
					m³/h	0																			
Model		230V	400V	P2		l/min	1	1,2	1,5	1,89	2,4	3	3,6	4,2	4,8	5,4	6	6,6	7,5	8,4	9,6	10,8	12	13,2	
		A		kW	HP	H (m) = Total head																			
BNM4	NM4 25/12A/A	1,3	0,75	0,25	0,34	6,1	6,1	6	6	5,9	5,8	5,5	5,2	4,8	4,4	3,9	3,3	-	-	-	-	-	-	-	-
BNM4	NM4 25/160B/A	1,65	0,95	0,37	0,5	7,8	7,7	7,6	7,6	7,5	7,5	7,2	6,9	6,6	6,1	5,5	4,6	3,6	-	-	-	-	-	-	-
BNM4	NM4 25/160A/A	1,65	0,95	0,37	0,5	9,4	9,2	9,1	9,1	9	9	8,7	8,5	8,2	7,8	7,2	6,5	5,6	3,7	-	-	-	-	-	-
BNM4	NM4 25/200C/B	1,65	0,95	0,37	0,5	11,7	11,5	11,4	11,4	11,3	11,2	11,1	10,9	10,7	10,5	10,2	9,8	9,4	8,6	7,7	6	3,6	-	-	-
BNM4	NM4 25/200B/B	2,6	1,5	0,55	0,75	13,2	13,2	13,2	13,2	13,1	13,1	13	12,9	12,7	12,5	12,3	11,9	11,5	11	10,3	8,9	6,9	4	-	-
BNM4	NM4 25/200A/C	3,3	1,9	0,75	1	14,5	14,5	14,5	14,5	14,5	14,5	14,4	14,3	14,2	14	13,8	13,5	13,2	12,7	12,1	11	9,2	6,7	2,9	-

Coverage chart n ≈ 2900 rpm

Three-phase

						Q = Flow																	
						m³/h	0																
Model		230V	400V	690V	P2		l/min	2,4	3	3,6	4,8	6	6,6	7,5	8,4	9,6	10,8	12	13,2	15	16,8	18	
		A			kW	HP	H (m) = Total head																
BNM	NM 25/12B/A	2,8	1,6	-	0,55	0,75	20,2	19,3	19,3	19,2	18,6	17,9	17,4	16,6	15,7	14,1	12,2	10	-	-	-	-	-
BNM	NM 25/12A/B	3,5	2	-	0,75	1	23,8	23,5	23,4	23,3	22,9	22,1	21,7	20,9	20	18,7	17,1	15,2	-	-	-	-	-
BNM	NM 25/160B/A	4,6	2,7	-	1,1	1,5	31,9	-	31	30,7	30	28,5	28	27	26	23	-	-	-	-	-	-	-
BNM	NM 25/160A/A	7,5	4,3	-	1,5	2	37	-	36,5	36,2	35,5	34,5	34	33,5	32,5	31	28,5	26	-	-	-	-	-
BNM	NM 25/20B/C	9,6	5,5	-	2,2	3	43,4	-	42,2	41,9	41,4	40,7	40,2	39,7	39	37,9	36,7	35,2	33,4	-	-	-	-
BNM	NM 25/20A/B	11,5	6,6	-	3	4	50,5	-	49,9	49,8	49,4	48,9	48,5	48,1	47,5	46,6	45,6	44,4	43	40,8	37,9	-	-
BNM	NM 25/20S/C	-	9,6	5,5	4	5,5	57,9	-	57,4	57,3	57	56,8	56,5	56,2	55,8	55,1	54,3	53,2	52	49,9	47,2	44,9	-
BNMD	NMD 25/190C/B	9,2	5,3	-	2,2	3	66	62	60,5	59	55,5	51	48,5	44	38	-	-	-	-	-	-	-	-
BNMD	NMD 25/190B/A	11,5	6,6	-	3	4	77	76	75	74	70	66	64	60	54	46	-	-	-	-	-	-	-
BNMD	NMD 25/190A/B	-	9,6	5,5	4	5,5	101	98	97	96	93,5	90	88	84	79	70	-	-	-	-	-	-	-

Single-phase

						Q = Flow											
						m³/h	0										
Model		230V	P2		P1	l/min	2,4	3	3,6	4,8	6	6,6	7,5	8,4	9,6	10,8	12
		A		kW	HP	kW	H (m) = Total head										
BNMM	NMM 25/12B/A	4,5	0,55	0,75	0,78	20,2	19,3	19,3	19,2	18,6	17,9	17,4	16,6	15,7	14,1	12,2	10
BNMM	NMM 25/12A/A	5,7	0,75	1	1,01	23,8	23,5	23,4	23,3	22,9	22,1	21,7	20,9	20	18,7	17,1	15,2
BNMM	NMM 25/160B	7,4	1,1	1,5	1,44	31,9	-	31	30,7	30	28,5	28	27	26	23	-	-
BNMM	NMM 25/160A	9,2	1,5	2	2	37	-	36,5	36,2	35,5	34,5	34	33,5	32,5	31	28,5	26

Three-phase

						Q = Flow													
						m³/h	0												
Model		230V	400V	690V	P2		l/min	6,6	7,5	8,4	9,6	10,8	12	13,2	15	16,8	18,9	21	24
		A			kW	HP	H (m) = Total head												
NM 10/F		4	2,3	-	0,55	0,75	13,2	12,5	12,5	12	11,5	11	10	9	7,5	-	-	-	-
NM 10/D		4	2,3	-	0,75	1	18,8	18	18	17,5	17	16,5	16	15,5	14	-	-	-	-
NM 10/A/A		4,6	2,7	-	1,1	1,5	23,5	23	23	22,5	22	21,5	21	20,5	19	-	-	-	-
NM 10/S/A		7,5	4,3	-	1,5	2	24	23,5	23,5	23	22,5	22	21,5	21	20,5	19	18,5	16,5	13
NM 11/B/A		7,5	4,3	-	1,5	2	30	29,5	29,5	29	28,5	27,5	27	26	25	22,5	-	-	-
NM 11/A/B		9,2	5,3	-	2,2	3	36	35,5	35,5	35	34,5	34	33,5	33	32	30	-	-	-
NM 12/D/B		9,2	5,3	-	2,2	3	41	38	37,5	37	36	35	33,5	32	-	-	-	-	-
NM 12/C/A		11,5	6,6	-	3	4	46,4	45	44,5	44	43,5	42,5	41	40	38	36	-	-	-
NM 12/A/B		-	9,6	5,5	4	5,5	56,8	57,5	57	56	55,5	55	54,5	53,5	51,5	49	-	-	-

Coverage chart n ≈ 2900 rpm

Single-phase

Model					Q = Flow															
					m³/h	0														
					l/min	6,6	7,5	8,4	9,6	10,8	12	13,2	15	16,8	18,9	21	24			
230V	P2			P1																
A	kW	HP	kW																	
					H (m) = Total head															
NMM 10/F	4,5	0,55	0,75	0,78		13,2	12,5	12,5	12	11,5	11	10	9	7,5	-	-	-	-	-	-
NMM 10/D	5,8	0,75	1	1,01		18,8	18	18	17,5	17	16,5	16	15,5	14	-	-	-	-	-	-
NMM 10/A	7,4	1,1	1,5	1,44		23,5	23	23	22,5	22	21,5	21	20,5	19	-	-	-	-	-	-
NMM 10/S	9,2	1,5	2	2		24	23,5	23,5	23	22,5	22	21,5	21	20,5	19	18,5	16,5	13		
NMM 11/B	9,2	1,5	2	2		27	26,5	25,5	25	24	23	22,5	21,5	19,5	17,5	-	-	-	-	-
NMM 11/A	11,2	1,8	2,5	2,5		30,2	30,2	30,1	29,8	29,4	28,8	28,1	27,4	26	24,5	-	-	-	-	-

Three-phase

Model						Q = Flow															
						m³/h	0														
						l/min	5,4	6	6,6	7,5	8,4	9,6	10,8	12	13,2	15	16,8	18,9	21	24	
400V	690V	P2																			
A	kW	HP																			
						H (m) = Total head															
BNMD	NMD 32/210D/B	9,6	5,5	4	5,5		79	71	69	67,5	65	62,5	58	53	46	37	-	-	-	-	-
BNMD	NMD 32/210C/A	10,8	6,2	5,5	7,5		88	84	83	82	81	79	76	73	69	64	54	-	-	-	-
BNMD	NMD 32/210B/A	14,3	8,3	7,5	10		109	104	103	102	100	98	95	92	88	84	76	-	-	-	-
BNMD	NMD 32/210A/B	18,5	10,7	9,2	12,5		119	114	113	112	110	108	105	103	99	96	90	-	-	-	-
BNMD	NMD 40/180D/B	9,6	5,5	4	5,5		62	-	-	-	60	59,5	57	56	53	51,5	48	44	39	34	25
BNMD	NMD 40/180C/A	10,8	6,2	5,5	7,5		71	-	-	-	69	68	67	66	64,5	63	60	57	53	48	40
BNMD	NMD 40/180B/A	14,3	8,3	7,5	10		87	-	-	-	87	86	85	84	82,5	81	78	75	71	66	59
BNMD	NMD 40/180A/B	18,5	10,7	9,2	12,5		94	-	-	-	94	93	92	91	89,5	88	85	82	78	74	67

Three-phase

Model						Q = Flow															
						m³/h	0														
						l/min	21	24	27	30	33	37,8	42	48	54	60	66				
230V	400V	P2																			
A	kW	HP																			
						H (m) = Total head															
BNM	NM 17/H/A	4,6	2,7	1,1	1,5		10	9,5	9,2	9	8,6	8,2	7,5	6,7	5,5	3,5	-	-			
BNM	NM 17/G/A	7,5	4,3	1,5	2		13	12	11,7	11,5	11,2	11	10,3	9,7	8,5	7	4	-			
BNM	NM 17/F/B	9,2	5,3	2,2	3		16,1	-	16	16	15,5	15	14,5	14	13	11,5	10	8			
BNM	NM 17/D/A	11,5	6,6	3	4		18,4	-	-	18	18	17,5	17	16,5	15,5	14	13	11,5			

Single-phase

Model					Q = Flow																
					m³/h	0															
					l/min	21	24	27	30	33	37,8	42	48	54	60						
230V	P2			P1																	
A	kW	HP	kW																		
					H (m) = Total head																
BNMM	NMM 17/H	7,4	1,1	1,5	1,44		10	9,5	9,2	9	8,6	8,2	7,5	6,7	5,5	3,5	-				
BNMM	NMM 17/G	9,2	1,5	2	2		13	12	11,7	11,5	11,2	11	10,3	9,7	8,5	7	4	-			

P1: Maximum power input.

P2: Rated motor power output.

H: Total head in m

Characteristic curves $n \approx 2900$ rpm

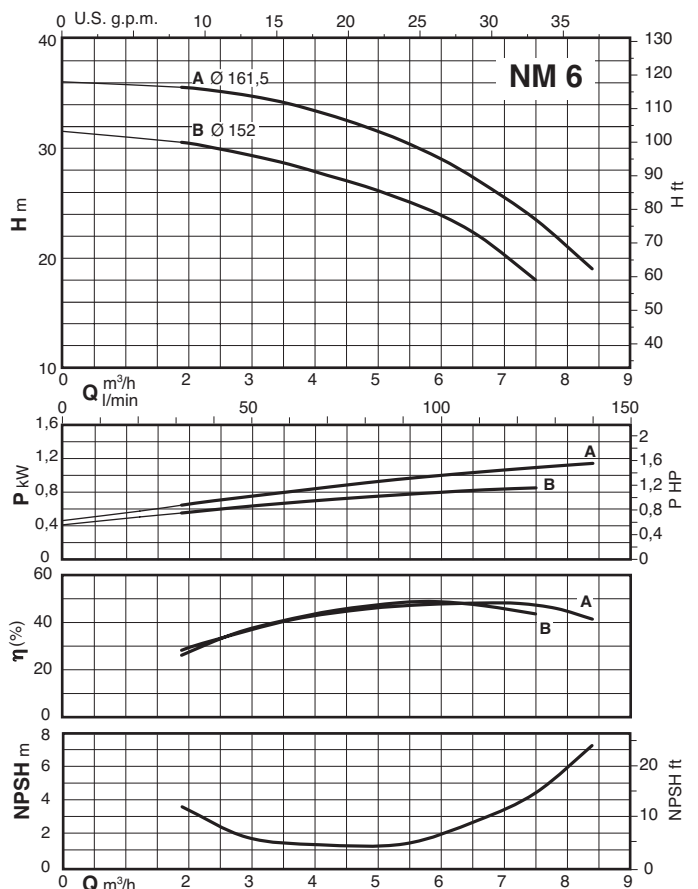
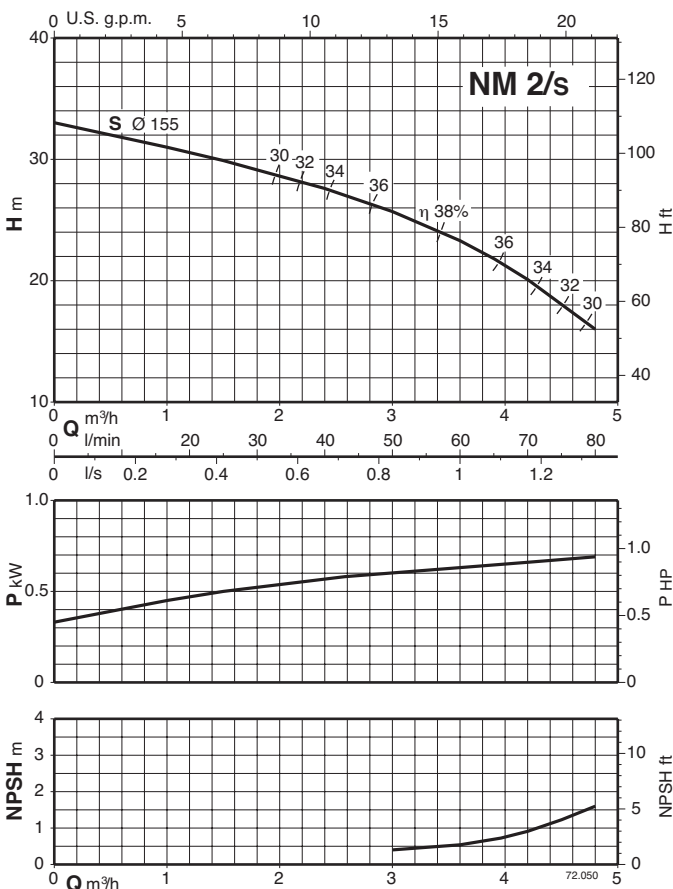
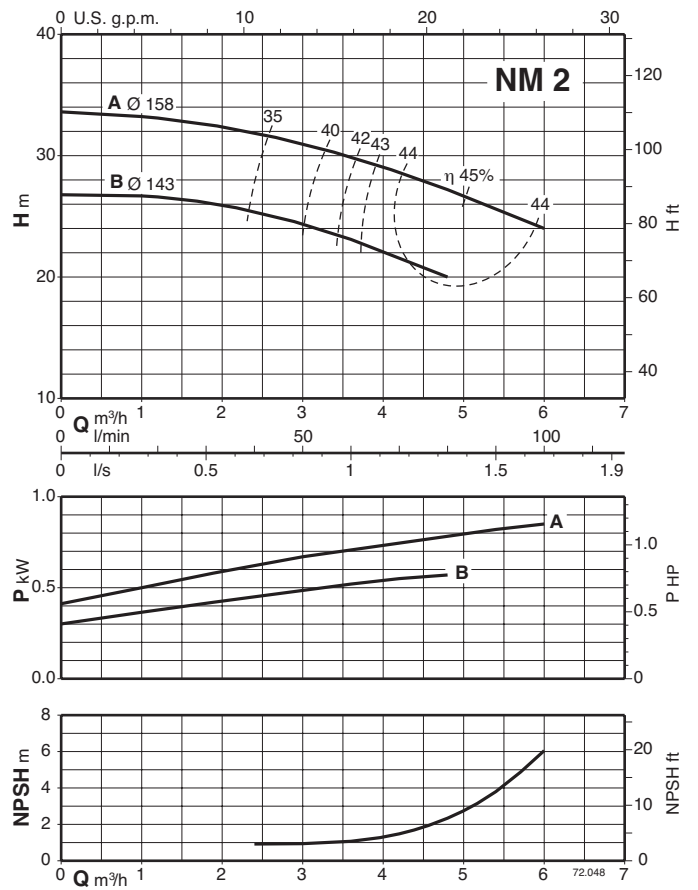
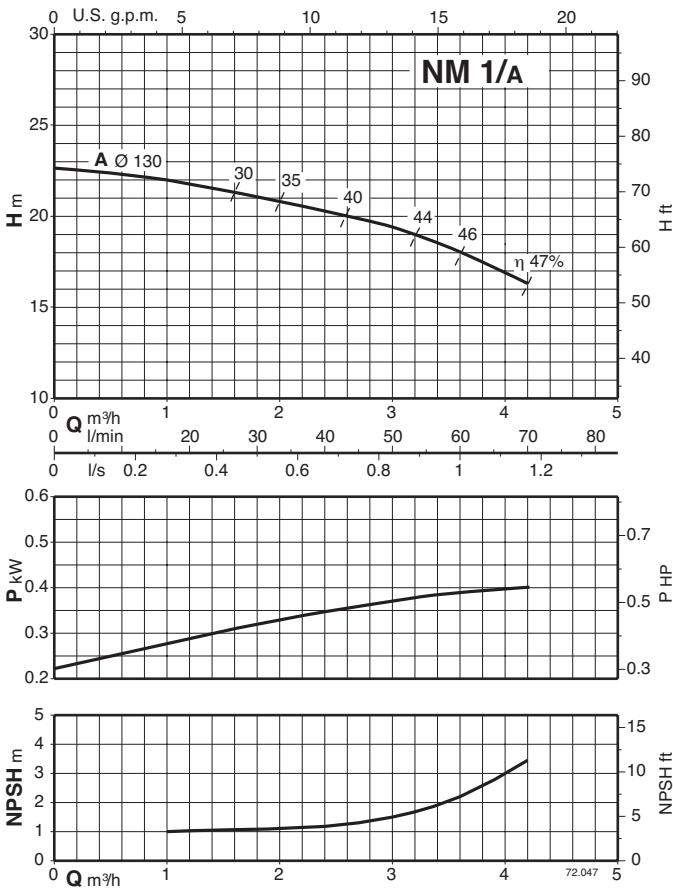

Characteristic curves $n \approx 1450$ rpm

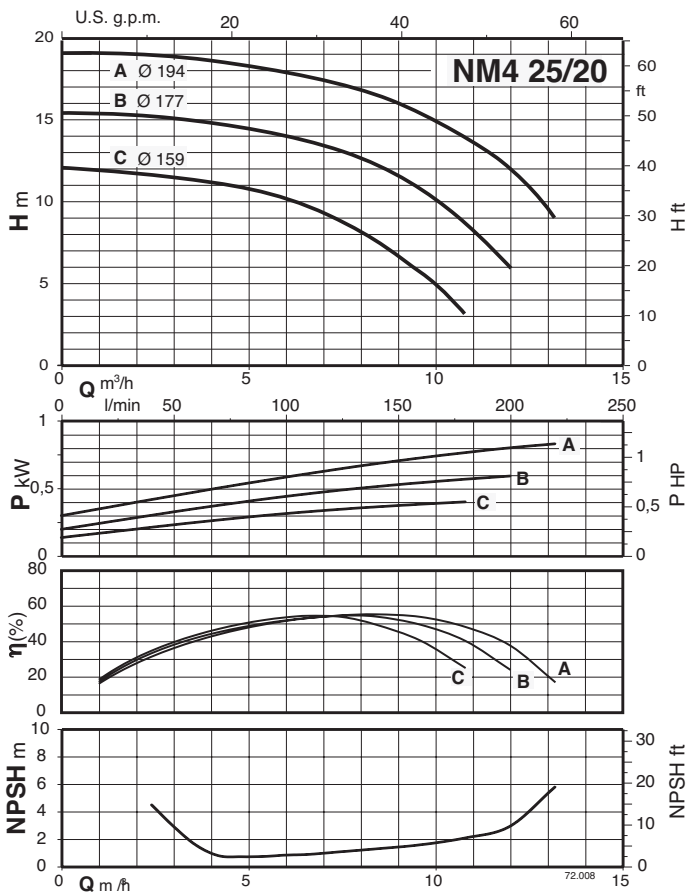
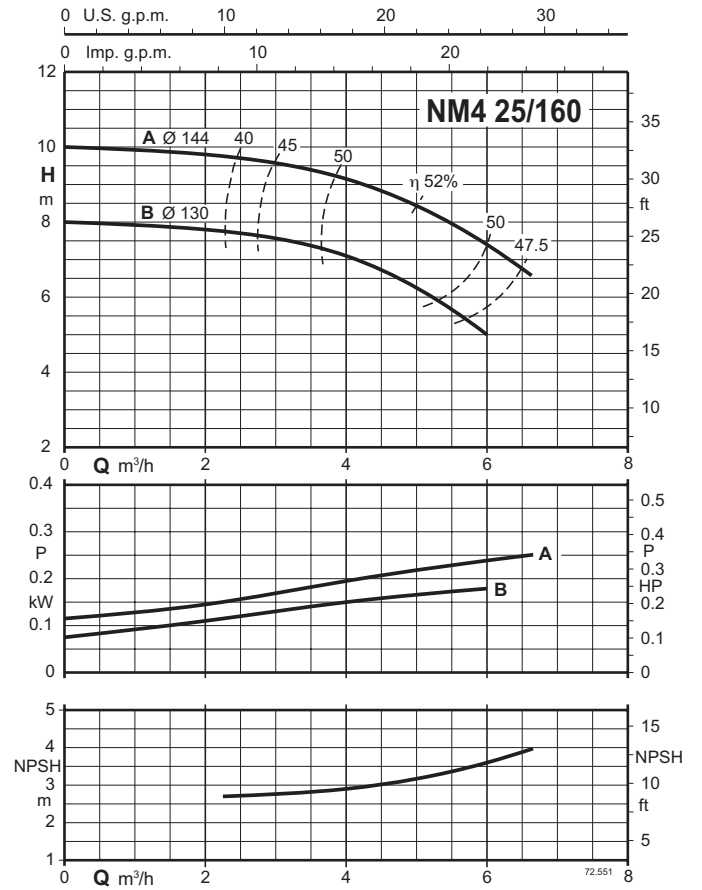
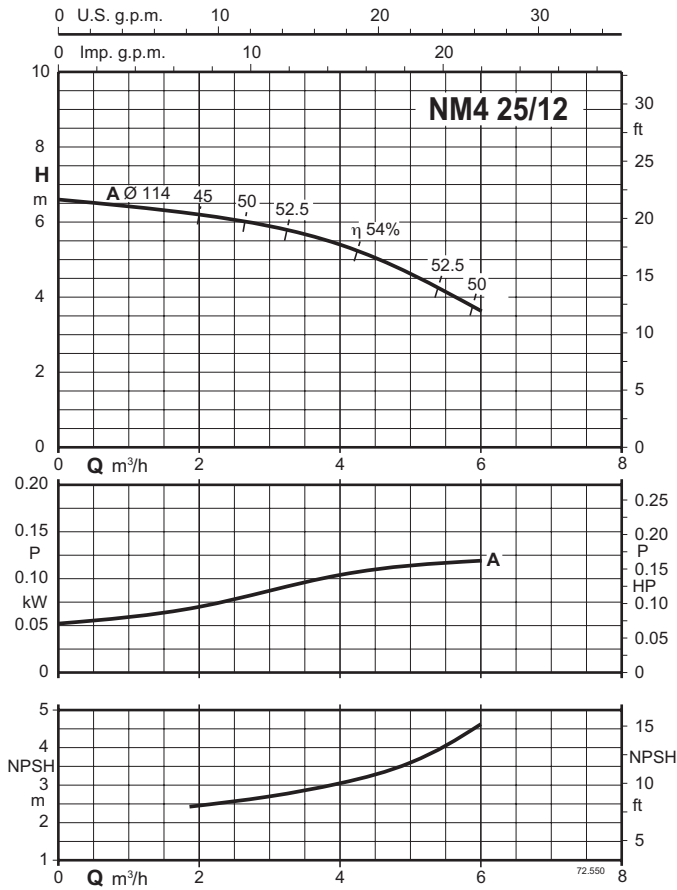

Characteristic curves $n \approx 2900$ rpm

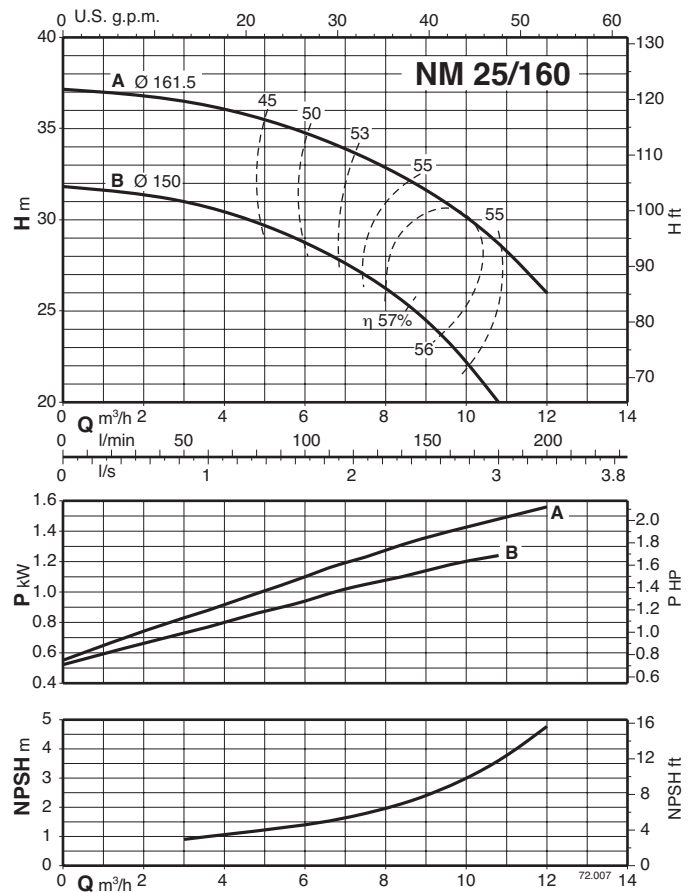
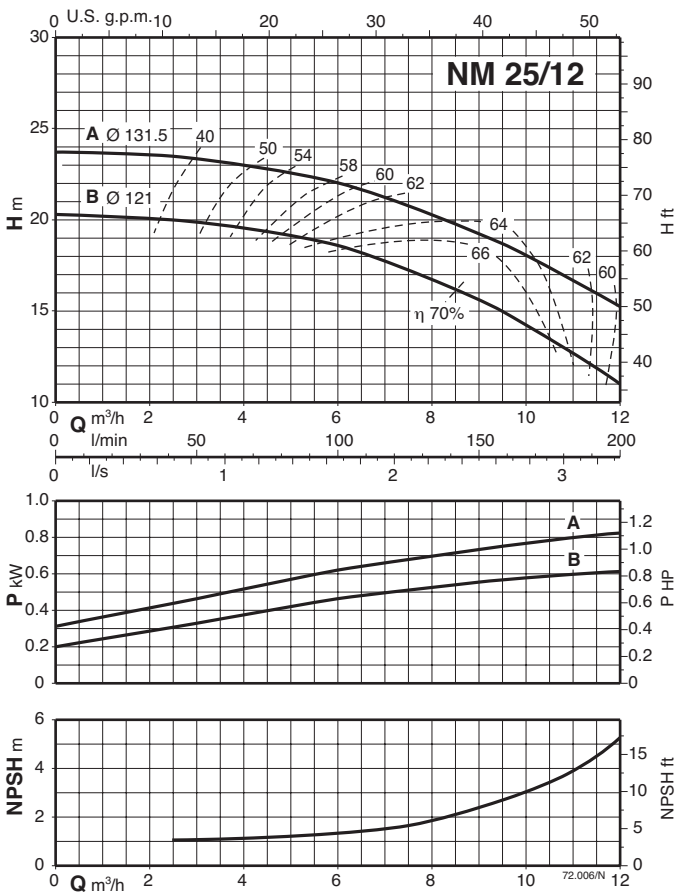
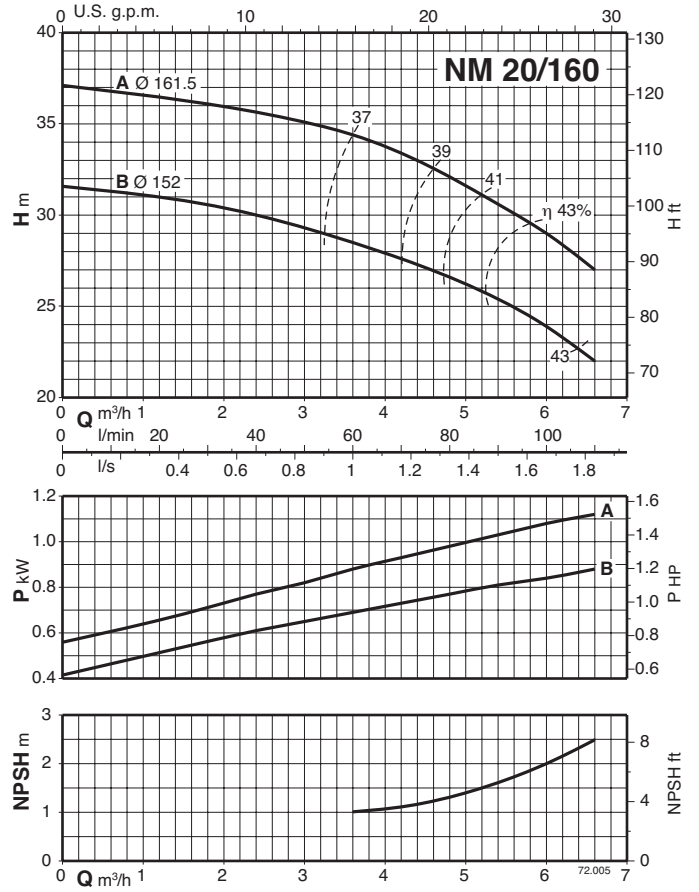
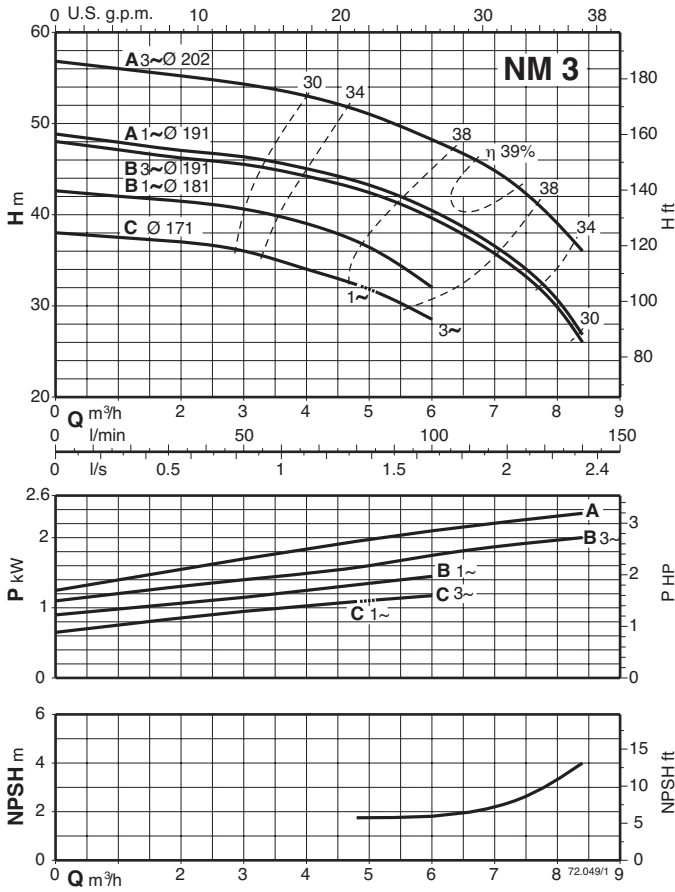

Characteristic curves $n \approx 2900$ rpm

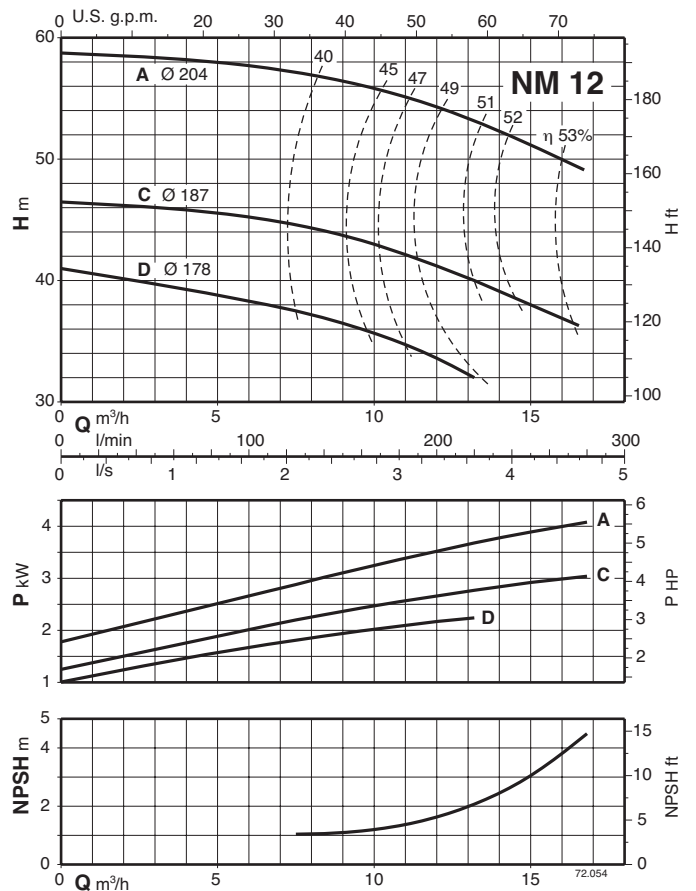
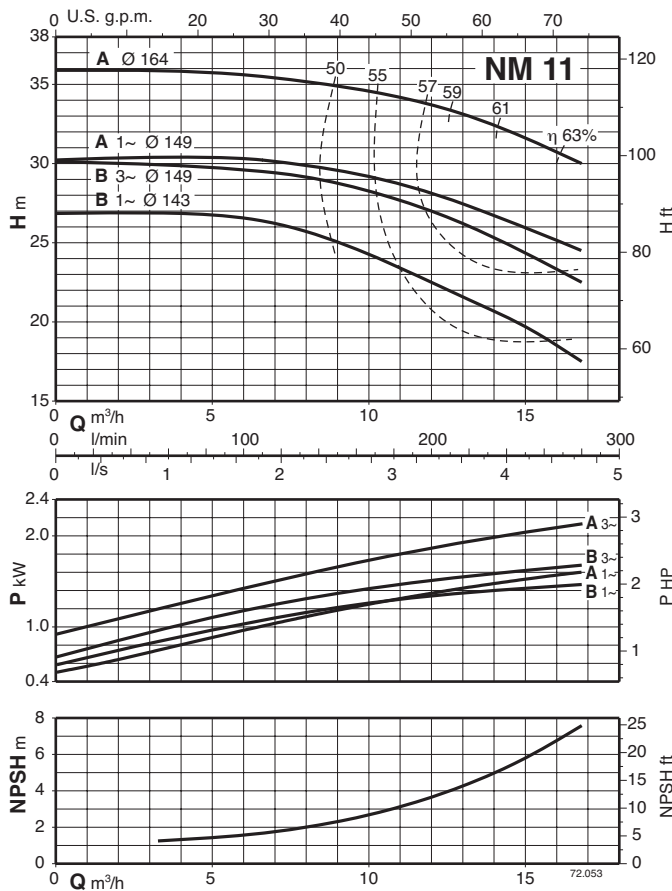
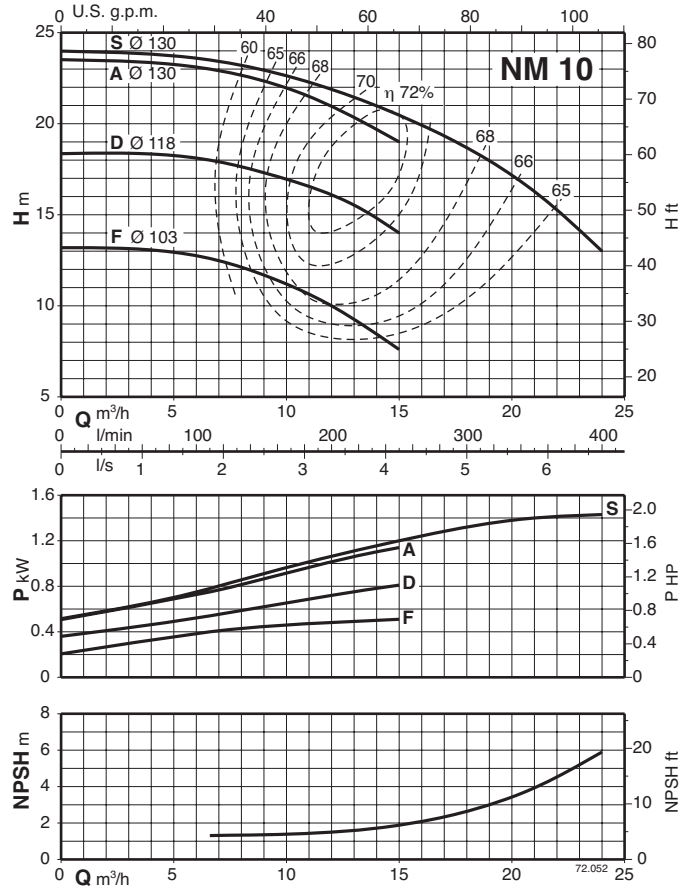
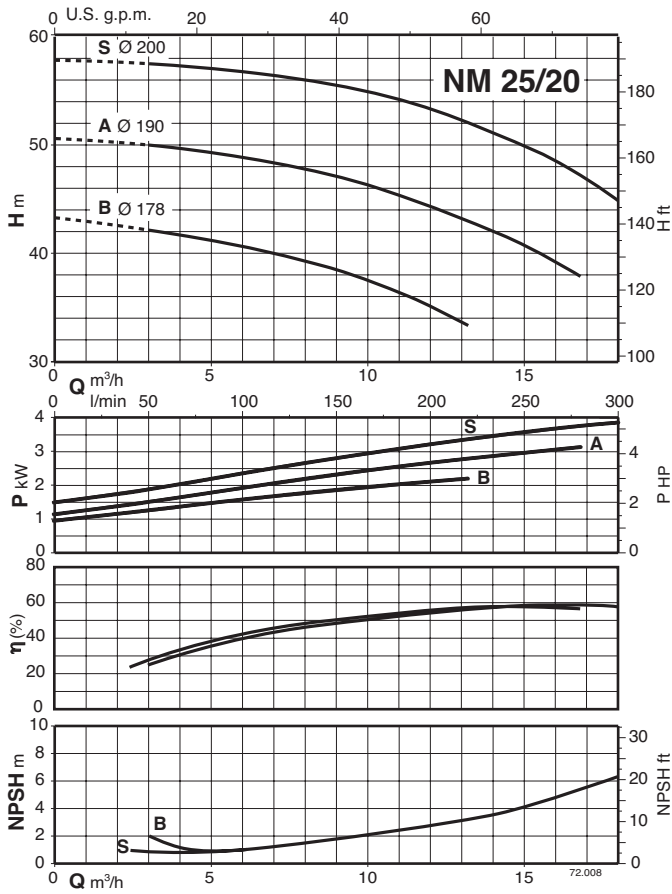

Characteristic curves $n \approx 2900$ rpm

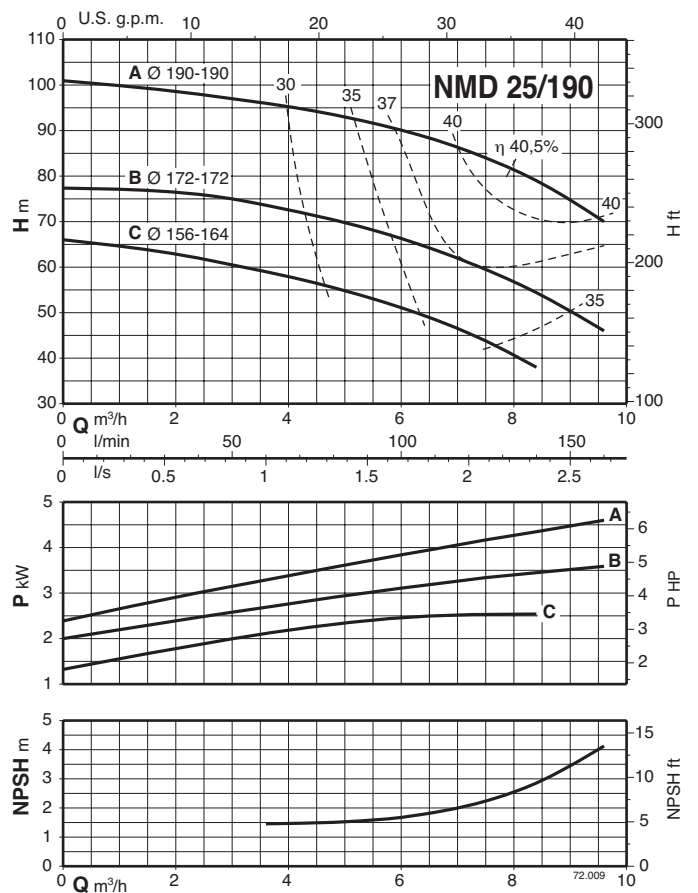
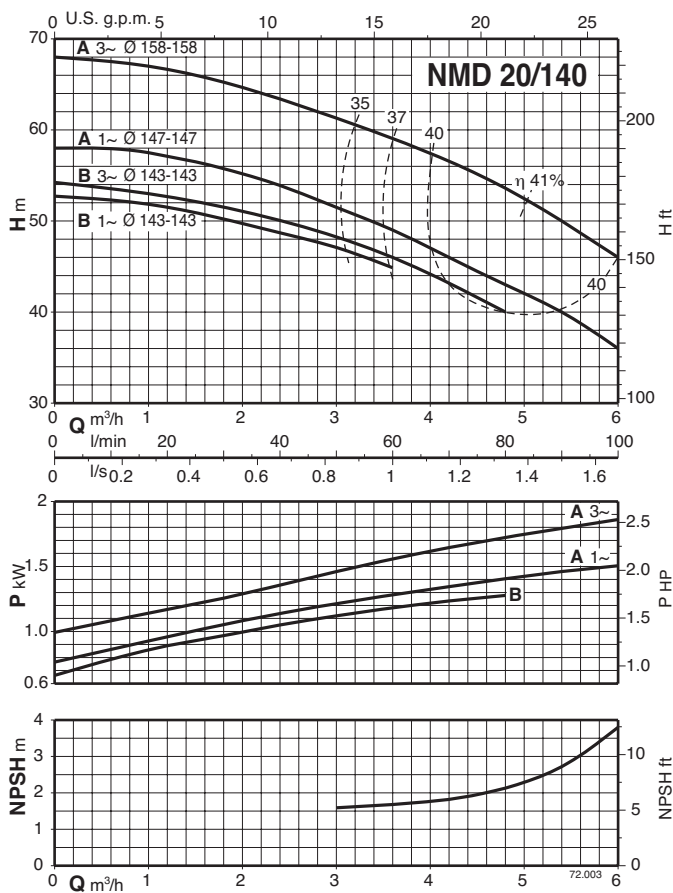
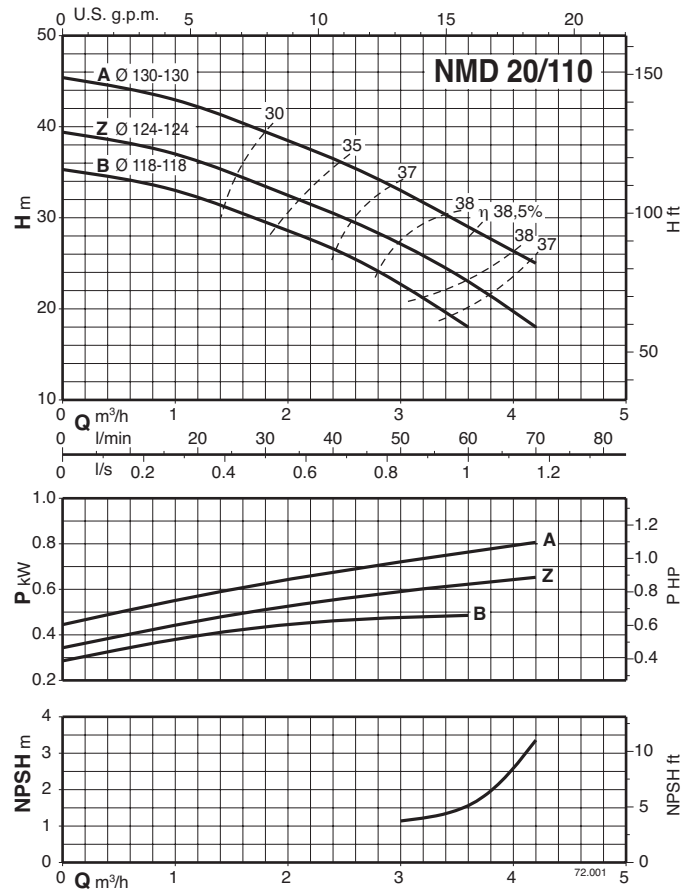
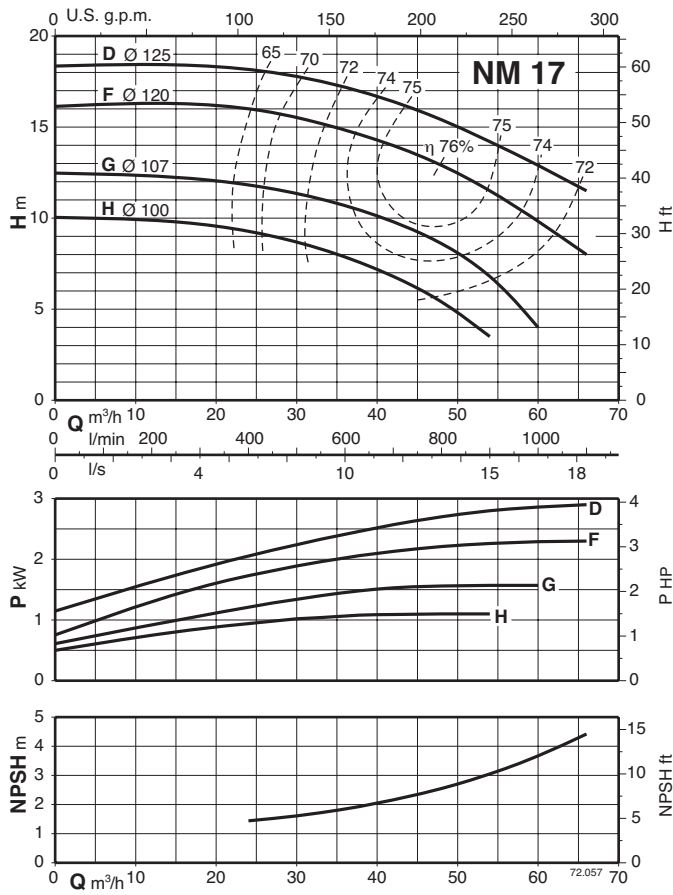

Characteristic curves $n \approx 2900$ rpm

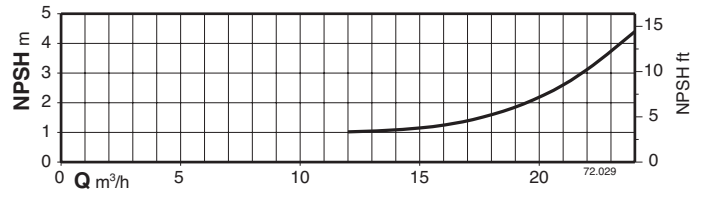
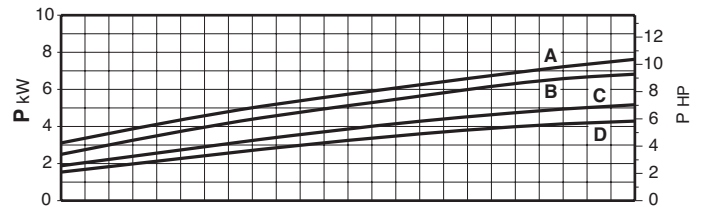
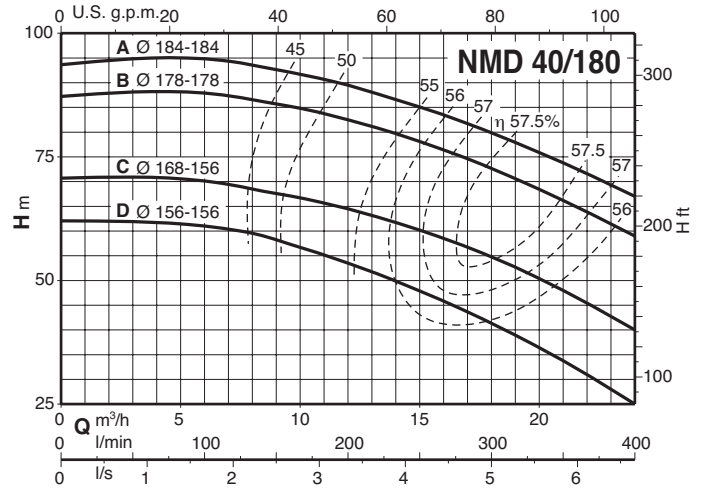
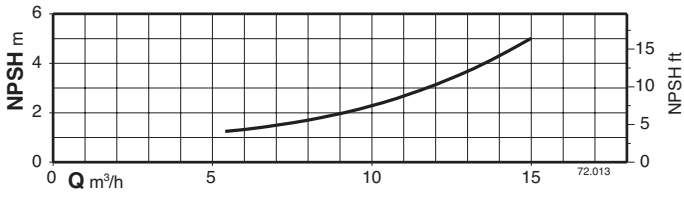
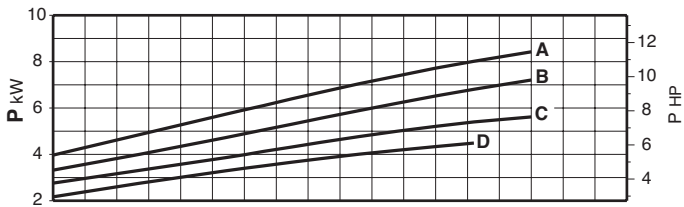
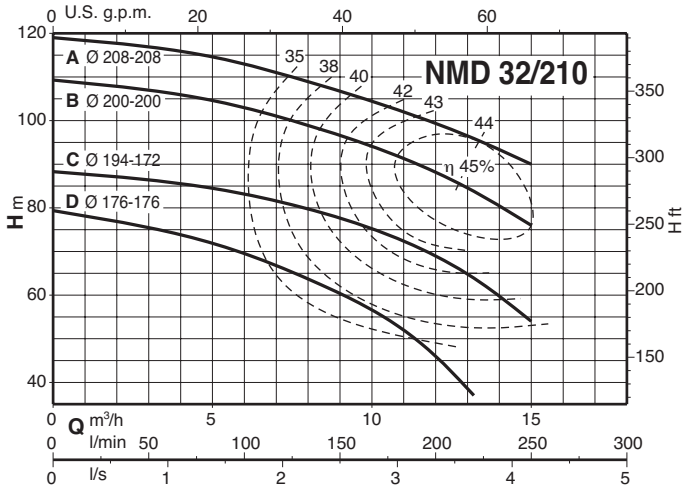

Dimensions and weights

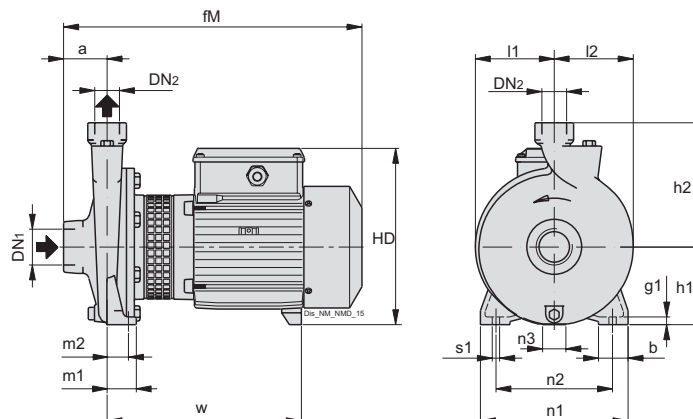

Three-phase

TYPE	ISO 228		mm															kg	
	DN1	DN2	a	b	fM	g1	h1	h2	HD	l1	l2	m1	m2	n1	n2	n3	s1	w	Weight
NM 1/A	G 1"	G 1"	40	35	261	10	80	132	179	76	81	40	32	170	140	20	9.5	174	8.8
NM 2/B/A	G 1"	G 1"	45	35	309	10	95	150	208	87	90	40	32	190	160	19.5	9.5	202	12.7
NM 2/S/A	G 1"	G 1"	45	35	309	10	95	150	208	87	90	40	32	190	160	19.5	9.5	202	13.2
NM 2/A/B	G 1"	G 1"	45	35	309	10	95	150	208	87	90	40	32	190	160	19.5	9.5	202	15.1
NM 6/B	G 1 1/4"	G 1"	53	38	349	11	100	150	213	92	96	37.5	27.5	190	150	19.5	9.5	234	17
NM 6/A	G 1 1/4"	G 1"	53	38	349	11	100	150	213	92	96	37.5	27.5	190	150	19.5	9.5	234	19
NM 3/C/A	G 1"	G 1"	50	45	377	12	112	180	242	111	114	55	43	245	205	31	11.5	247	23.3
NM 3/B/A	G 1"	G 1"	50	45	377	12	112	180	242	111	114	55	43	245	205	31	11.5	247	25
NM 3/A/B	G 1"	G 1"	50	45	417	12	112	180	242	111	114	55	43	245	205	31	11.5	287	28.2
NM 10/F	G 2"	G 1 1/4"	63	50	391	12	100	150	230	91	97	50	35	190	140	29	14	247	18.2
NM 10/D	G 2"	G 1 1/4"	63	50	391	12	100	150	230	91	97	50	35	190	140	29	14	247	18.2
NM 10/A/A	G 2"	G 1 1/4"	63	50	391	12	100	150	230	91	97	50	35	190	140	29	14	247	20.7
NM 10/S/A	G 2"	G 1 1/4"	63	50	391	12	100	150	230	91	97	50	35	190	140	29	14	247	21.9
NM 11/B/A	G 2"	G 1 1/4"	70	50	403	14	112	170	242	103	110	50	35	210	160	31	14	253	24.9
NM 11/A/B	G 2"	G 1 1/4"	70	50	443	14	112	170	242	103	110	50	35	210	160	31	14	293	28.8
NM 12/D/B	G 2"	G 1 1/4"	70	50	443	14	132	190	262	120	126	50	35	240	190	35	14	295	31.5
NM 12/C/A	G 2"	G 1 1/4"	70	50	469	14	132	190	272	120	126	50	35	240	190	32	14	294	38
NM 12/A/B	G 2"	G 1 1/4"	70	50	469	14	132	190	272	120	126	50	35	240	190	32	14	294	42.6
NM 17/H/A	G 2 1/2"	G 2 1/2"	80	50	423	14	112	160	242	96	112	50	35	210	160	31	14	263	22.8
NM 17/G/A	G 2 1/2"	G 2 1/2"	80	50	423	14	112	160	242	96	112	50	35	210	160	31	14	263	24.3
NM 17/F/B	G 2 1/2"	G 2 1/2"	80	50	463	14	112	160	242	96	112	50	35	210	160	31	14	303	27.7
NM 17/D/A	G 2 1/2"	G 2 1/2"	80	50	479	14	112	160	252	96	112	50	35	210	160	20	14	292	33.7
NM 20/160B	G 1 1/4"	G 3/4"	53	38	380	11	100	150	230	93	96	37.5	27.5	190	150	29	9.5	246	18.4
NM 20/160A/A	G 1 1/4"	G 3/4"	53	38	380	11	100	150	230	93	96	37.5	27.5	190	150	29	9.5	246	20.8
NM 25/12B/A	G 1 1/2"	G 1"	56	38	313	11	90	140	203	85	88	37.5	27.5	170	130	20	9.5	195	12.5
NM 25/12A/B	G 1 1/2"	G 1"	56	38	313	11	90	140	203	85	88	37.5	27.5	170	130	20	9.5	195	14.6
NM 25/160B/A	G 1 1/2"	G 1"	56	38	383	11	100	160	230	102	102	37.5	27.5	190	150	29	9.5	246	20.7
NM 25/160A/A	G 1 1/2"	G 1"	56	38	383	11	100	160	230	102	102	37.5	27.5	190	150	29	9.5	246	22.5
NM 25/20B/C	G 1 1/2"	G 1"	63	45	433	10	125	180	255	126	126	45	32.5	245	200	34	11.5	291	29.6
NM 25/20A/B	G 1 1/2"	G 1"	63	45	459	10	125	180	265	126	126	45	32.5	245	200	31	11.5	291	35.9
NM 25/20S/C	G 1 1/2"	G 1"	63	45	459	10	125	180	265	126	126	45	32.5	245	200	31	11.5	291	40.6
BNM 17/H/A	G 2 1/2"	G 2 1/2"	80	50	423	14	112	160	242	96	112	50	35	210	160	31	14	263	25.5
BNM 17/G/A	G 2 1/2"	G 2 1/2"	80	50	423	14	112	160	242	96	112	50	35	210	160	31	14	263	27
BNM 17/F/B	G 2 1/2"	G 2 1/2"	80	50	463	14	112	160	242	96	112	50	35	210	160	31	14	303	30.4
BNM 17/D/A	G 2 1/2"	G 2 1/2"	80	50	479	14	112	160	252	96	112	50	35	210	160	20	14	292	37.5
BNM 20/160B	G 1 1/4"	G 3/4"	53	38	420	11	100	150	230	93	96	37.5	27.5	190	150	29	9.5	286	20.1
BNM 20/160A/A	G 1 1/4"	G 3/4"	53	38	420	11	100	150	230	93	96	37.5	27.5	190	150	29	9.5	286	22.2
BNM 25/12B/A	G 1 1/2"	G 1"	56	38	313	11	90	140	203	85	88	37.5	27.5	170	130	20	9.5	195	13.7
BNM 25/12A/B	G 1 1/2"	G 1"	56	38	313	11	90	140	203	85	88	37.5	27.5	170	130	20	9.5	195	15.7
BNM 25/160B/A	G 1 1/2"	G 1"	56	38	423	11	100	160	230	102	102	37.5	27.5	190	150	29	9.5	286	22.6
BNM 25/160A/A	G 1 1/2"	G 1"	56	38	423	11	100	160	230	102	102	37.5	27.5	190	150	29	9.5	286	24.2
BNM 25/200B/C	G 1 1/2"	G 1"	63	45	445	10	125	180	255	126	126	45	32.5	245	200	34	11.5	303	33.4
BNM 25/200A/B	G 1 1/2"	G 1"	63	45	460	10	125	180	265	126	126	45	32.5	245	200	31	11.5	292	39.9
BNM 25/200S/C	G 1 1/2"	G 1"	63	45	460	10	125	180	265	126	126	45	32.5	245	200	31	11.5	292	43.9

Dimensions and weights

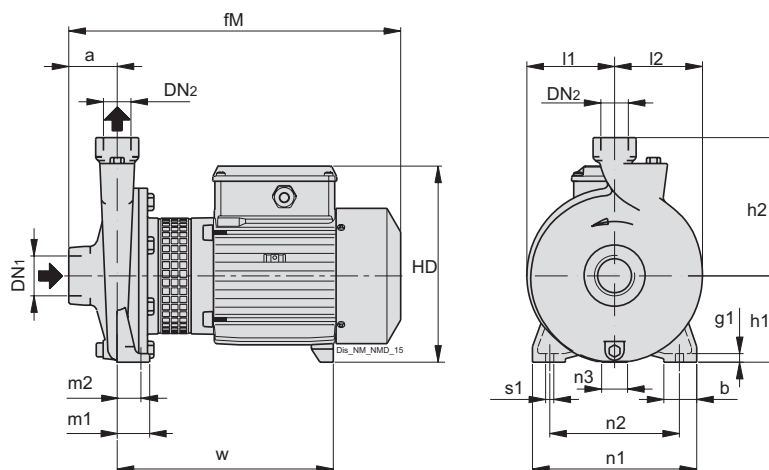

TYPE	ISO 228		mm																kg
	DN1	DN2	a	b	fM	g1	h1	h2	HD	l1	l2	m1	m2	n1	n2	n3	s1	w	Weight
NM4 25/12A/A	G 1 1/2"	G 1"	56	38	313	11	90	140	203	85	88	37.5	27.5	170	130	20	9.5	195	12.2
NM4 25/160B/A	G 1 1/2"	G 1"	56	38	383	11	100	160	230	102	102	37.5	27.5	190	150	29	9.5	246	18.7
NM4 25/160A/A	G 1 1/2"	G 1"	56	38	383	11	100	160	230	102	102	37.5	27.5	190	150	29	9.5	246	18.8
NM4 25/200C/B	G 1 1/2"	G 1"	63	45	390	10	125	180	255	126	126	45	32.5	245	200	34	11.5	248	22.7
NM4 25/200B/B	G 1 1/2"	G 1"	63	45	390	10	125	180	255	126	126	45	32.5	245	200	34	11.5	248	24.4
NM4 25/200A/C	G 1 1/2"	G 1"	63	45	430	10	125	180	255	126	126	45	32.5	245	200	34	11.5	288	29.7
BNM4 25/160B/A	G 1 1/2"	G 1"	56	38	383	11	100	160	230	102	102	37.5	27.5	190	150	29	9.5	286	19.9
BNM4 25/160A/A	G 1 1/2"	G 1"	56	38	383	11	100	160	230	102	102	37.5	27.5	190	150	29	9.5	286	19.9
BNM4 25/200C/B	G 1 1/2"	G 1"	63	45	365	10	125	180	255	126	126	45	32.5	245	200	34	11.5	263	26.3
BNM4 25/200B/B	G 1 1/2"	G 1"	63	45	365	10	125	180	255	126	126	45	32.5	245	200	34	11.5	263	-
BNM4 25/200A/C	G 1 1/2"	G 1"	63	45	405	10	125	180	254	126	126	45	32.5	245	200	34	11.5	263	32.6

Dimensions and weights

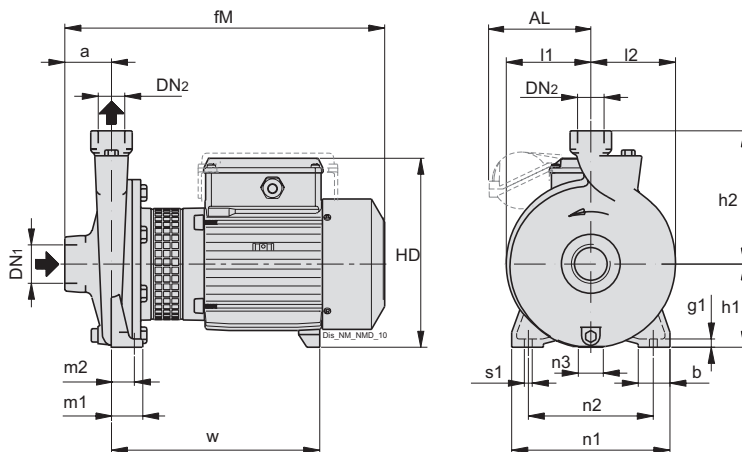

Single-phase

TYPE	ISO 228		mm																	kg
	DN1	DN2	a	AL	b	fM	g1	h1	h2	HD	l1	l2	m1	m2	n1	n2	n3	s1	w	Weight
NMM 1/A	G 1"	G 1"	40	-	35	261	10	80	132	179	76	81	40	32	170	140	20	9.5	174	8.5
NMM 2/B/A	G 1"	G 1"	45	-	35	309	10	95	150	208	87	90	40	32	190	160	19.5	9.5	202	13.8
NMM 2/S/A	G 1"	G 1"	45	-	35	309	10	95	150	208	87	90	40	32	190	160	19.5	9.5	202	14.5
NMM 2/A/A	G 1"	G 1"	45	-	35	309	10	95	150	208	87	90	40	32	190	160	19.5	9.5	202	15.1
NMM 6/B	G 1 1/4"	G 1"	53	-	38	349	11	100	150	213	92	96	37.5	27.5	190	150	19.5	9.5	234	17.1
NMM 6/A	G 1 1/4"	G 1"	53	-	38	349	11	100	150	213	92	96	37.5	27.5	190	150	19.5	9.5	234	19.2
NMM 3/C	G 1"	G 1"	50	-	45	377	12	112	180	242	111	114	55	43	245	205	31	11.5	247	23.2
NMM 3/B	G 1"	G 1"	50	-	45	377	12	112	180	242	111	114	55	43	245	205	31	11.5	247	25.2
NMM 3/A/A	G 1"	G 1"	50	131	45	417	12	112	180	247	111	114	55	43	245	205	31	11.5	287	28.6
NMM 10/F	G 2"	G 1 1/4"	63	-	50	391	12	100	150	230	91	97	50	35	190	140	29	14	247	19.2
NMM 10/D	G 2"	G 1 1/4"	63	-	50	391	12	100	150	230	91	97	50	35	190	140	29	14	247	20.5
NMM 10/A	G 2"	G 1 1/4"	63	-	50	391	12	100	150	230	91	97	50	35	190	140	29	14	247	22.2
NMM 10/S	G 2"	G 1 1/4"	63	-	50	391	12	100	150	230	91	97	50	35	190	140	29	14	247	22.2
NMM 11/B	G 2"	G 1 1/4"	70	-	50	403	14	112	170	242	103	110	50	35	210	160	31	14	253	25
NMM 11/A	G 2"	G 1 1/4"	70	131	50	443	14	112	170	247	103	110	50	35	210	160	31	14	293	28.5
NMM 17/H	G 2 1/2"	G 2 1/2"	80	-	50	423	14	112	160	242	96	112	50	35	210	160	31	14	263	23.7
NMM 17/G	G 2 1/2"	G 2 1/2"	80	-	50	423	14	112	160	242	96	112	50	35	210	160	31	14	263	23.7
NMM 20/160B	G 1 1/4"	G 3/4"	53	-	38	380	11	100	150	230	93	96	37.5	27.5	190	150	29	9.5	246	20.8
NMM 20/160A	G 1 1/4"	G 3/4"	53	-	38	380	11	100	150	230	93	96	37.5	27.5	190	150	29	9.5	246	22.5
NMM 25/12B/A	G 1 1/2"	G 1"	56	-	38	313	11	90	140	203	85	88	37.5	27.5	170	130	20	9.5	195	13.5
NMM 25/12A/A	G 1 1/2"	G 1"	56	-	38	313	11	90	140	203	85	88	37.5	27.5	170	130	20	9.5	195	14.7
NMM 25/160B	G 1 1/2"	G 1"	56	-	38	383	11	100	160	230	102	102	37.5	27.5	190	150	29	9.5	246	21.2
NMM 25/160A	G 1 1/2"	G 1"	56	-	38	383	11	100	160	230	102	102	37.5	27.5	190	150	29	9.5	246	23
BNMM 20/160B	G 1 1/4"	G 3/4"	53	-	38	420	11	100	150	230	93	96	37.5	27.5	190	150	29	9.5	286	-
BNMM 20/160A	G 1 1/4"	G 3/4"	53	-	38	420	11	100	150	230	93	96	37.5	27.5	190	150	29	9.5	286	23.9
BNMM 25/12B/A	G 1 1/2"	G 1"	56	-	38	313	11	90	140	203	85	88	37.5	27.5	170	130	20	9.5	195	13.7
BNMM 25/12A/A	G 1 1/2"	G 1"	56	-	38	313	11	90	140	203	85	88	37.5	27.5	170	130	20	9.5	195	15.7
BNMM 25/160B	G 1 1/2"	G 1"	56	-	38	423	11	100	160	230	102	102	37.5	27.5	190	150	29	9.5	286	24.3
BNMM 25/160A	G 1 1/2"	G 1"	56	-	38	423	11	100	160	230	102	102	37.5	27.5	190	150	29	9.5	286	24.3
BNMM 17/H	G 2 1/2"	G 2 1/2"	80	-	50	423	14	112	160	242	96	112	50	35	210	160	31	14	263	26.5
BNMM 17/G	G 2 1/2"	G 2 1/2"	80	-	50	423	14	112	160	242	96	112	50	35	210	160	31	14	263	26.5

Dimensions and weights

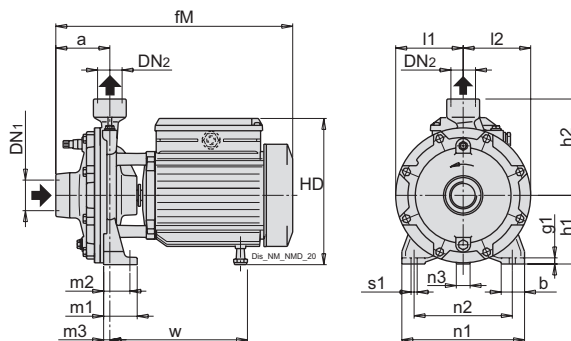

Three-phase

TYPE	ISO 228		mm																	kg Weight
	DN1	DN2	a	b	fM	g1	h1	h2	HD	l1	l2	m1	m2	m3	n1	n2	n3	s1	w	
NMD 20/110B/A	G 1 1/4"	G 1"	74	38	325	10	95	132	206	93	93	46	36	8.5	170	130	19.5	9.5	189	12.2
NMD 20/110Z/A	G 1 1/4"	G 1"	74	38	325	10	95	132	206	93	93	46	36	8.5	170	130	19.5	9.5	189	13.4
NMD 20/110A/B	G 1 1/4"	G 1"	74	38	325	10	95	132	206	93	93	46	36	8.5	170	130	19.5	9.5	189	15.5
BNMD 20/110B/A	G 1 1/4"	G 1"	74	38	325	10	95	132	206	93	93	46	36	8.5	170	130	19.5	9.5	189	13.6
BNMD 20/110Z/A	G 1 1/4"	G 1"	74	38	325	10	95	132	206	93	93	46	36	8.5	170	130	19.5	9.5	189	14
BNMD 20/110A/B	G 1 1/4"	G 1"	74	38	325	10	95	132	206	93	93	46	36	8.5	170	130	19.5	9.5	189	16.5

Single-phase

TYPE	ISO 228		mm																	kg Weight
	DN1	DN2	a	b	fM	g1	h1	h2	HD	l1	l2	m1	m2	m3	n1	n2	n3	s1	w	
NMDM 20/110B/A	G 1 1/4"	G 1"	74	38	325	10	95	132	206	93	93	46	36	8.5	170	130	19.5	9.5	189	13.2
NMDM 20/110Z/A	G 1 1/4"	G 1"	74	38	325	10	95	132	206	93	93	46	36	8.5	170	130	19.5	9.5	189	14.5
NMDM 20/110A/A	G 1 1/4"	G 1"	74	38	325	10	95	132	206	93	93	46	36	8.5	170	130	19.5	9.5	189	15.5
BNMDM 20/110B/A	G 1 1/4"	G 1"	74	38	325	10	95	132	206	93	93	46	36	8.5	170	130	19.5	9.5	189	14.3
BNMDM 20/110Z/A	G 1 1/4"	G 1"	74	38	325	10	95	132	206	93	93	46	36	8.5	170	130	19.5	9.5	189	-
BNMDM 20/110A/A	G 1 1/4"	G 1"	74	38	325	10	95	132	206	93	93	46	36	8.5	170	130	19.5	9.5	189	16.4

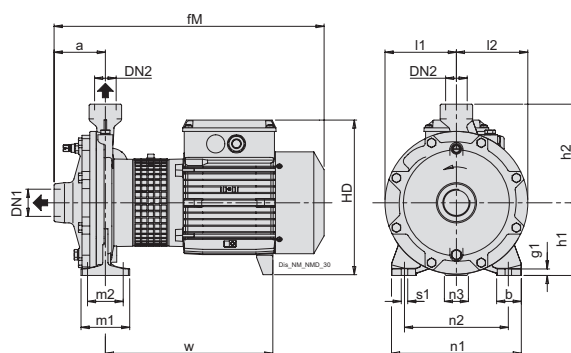

Three-phase

TYPE	ISO 228		mm																	kg Weight
	DN1	DN2	a	b	fM	g1	h1	h2	HD	l1	l2	m1	m2	n1	n2	n3	s1	w		
NMD 20/140B/A	G 1 1/4"	G 1"	79	38	416	10	112	150	242	110	110	75	55	200	160	31	9.5	257	23.5	
NMD 20/140A/A	G 1 1/4"	G 1"	79	38	416	10	112	150	242	110	110	75	55	200	160	31	9.5	257	25.2	
BNMD 20/140B/A	G 1 1/4"	G 1"	79	38	416	10	112	150	242	110	110	75	55	200	160	31	9.5	257	26.5	
BNMD 20/140A/A	G 1 1/4"	G 1"	79	38	416	10	112	150	242	110	110	75	55	200	160	31	9.5	257	22.9	

Single-phase

TYPE	ISO 228		mm																	kg Weight
	DN1	DN2	a	b	fM	g1	h1	h2	HD	l1	l2	m1	m2	n1	n2	n3	s1	w		
NMDM 20/140BE	G 1 1/4"	G 1"	79	38	416	10	112	150	242	110	110	75	55	200	160	31	9.5	257	23.6	
NMDM 20/140AE	G 1 1/4"	G 1"	79	38	416	10	112	150	242	110	110	75	55	200	160	31	9.5	257	25.7	
BNMDM 20/140BE	G 1 1/4"	G 1"	79	38	416	10	112	150	242	110	110	75	55	200	160	31	9.5	257	27.5	
BNMDM 20/140AE	G 1 1/4"	G 1"	79	38	416	10	112	150	242	110	110	75	55	200	160	31	9.5	257	28.2	

Dimensions and weights

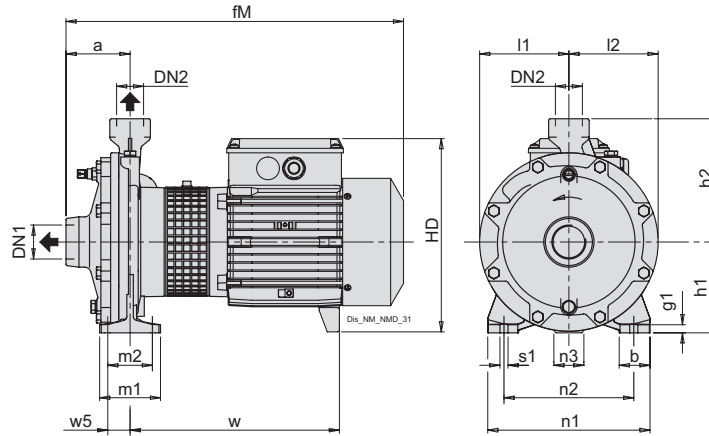

Three-phase

TYPE			mm																	kg
	DN1	DN2	a	b	fM	g1	h1	h2	HD	l1	l2	m1	m2	n1	n2	n3	s1	w	w5	
NMD 25/190C/B	G 1 1/2"	G 1"	97	50	490	12	140	180	270	133	133	100	70	250	190	36	14	316	35	41.2
NMD 25/190B/A	G 1 1/2"	G 1"	97	50	505	12	140	180	280	133	133	100	70	250	190	34	14	304	35	48.3
NMD 25/190A/B	G 1 1/2"	G 1"	97	50	505	12	140	180	280	133	133	100	70	250	190	34	14	304	35	52.4
BNMD 25/190C/B	G 1 1/2"	G 1"	97	50	490	12	140	180	270	133	133	100	70	250	190	36	14	316	35	45
BNMD 25/190B/A	G 1 1/2"	G 1"	97	50	505	12	140	180	280	133	133	100	70	250	190	34	14	304	35	53.9
BNMD 25/190A/B	G 1 1/2"	G 1"	97	50	505	12	140	180	280	133	133	100	70	250	190	34	14	304	35	56.2
NMD 40/180D/B	G 2"	G 1 1/2"	121	50	535	12	150	215	290	145	145	100	70	265	212	35	14	310	41	59.3
NMD 40/180C/A	G 2"	G 1 1/2"	121	50	587	12	150	215	317	145	145	100	70	265	212	32	14	341	41	71.4
NMD 40/180B/A	G 2"	G 1 1/2"	121	50	587	12	150	215	317	145	145	100	70	265	212	32	14	341	41	75.2
NMD 40/180A/B	G 2"	G 1 1/2"	121	50	632	12	150	215	340	145	145	100	70	265	212	29	14	366	41	96.5

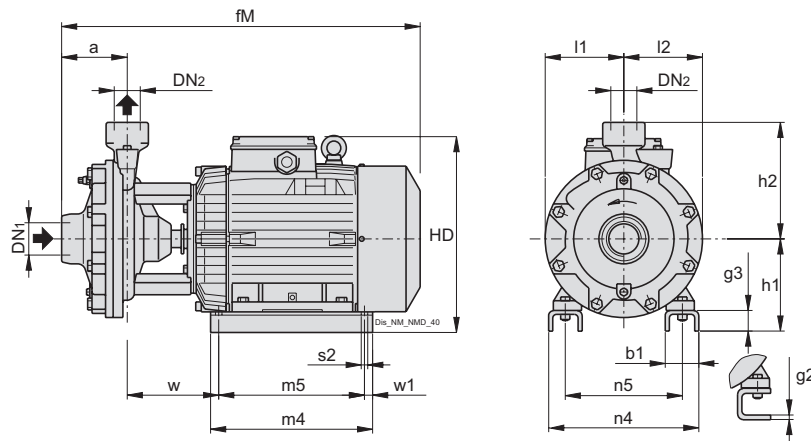

Three-phase

TYPE	ISO 228		mm																	kg
	DN1	DN2	a	b1	fM	g2	g3	h1	h2	HD	l1	l2	m4	m5	n4	n5	s2	w	w1	
NMD 32/210D/B	G 2"	G 1 1/4"	110	54	530	6	-	155	215	295	150	150	205	175	180	140	10	140	15	60.7
NMD 32/210C/A	G 2"	G 1 1/4"	110	68	583	-	38	150	215	312	150	150	280	250	258	190	12	139	15	71
NMD 32/210B/A	G 2"	G 1 1/4"	110	68	583	-	38	150	215	312	150	150	280	250	258	190	12	139	15	70
NMD 32/210A/B	G 2"	G 1 1/4"	110	70	627	-	38	170	215	360	150	150	298	268	286	216	12	152	15	97.5
BNMD 32/210D/B	G 2"	G 1 1/4"	110	54	530	6	-	155	215	295	150	150	205	175	180	140	10	140	15	64.8
BNMD 32/210C/A	G 2"	G 1 1/4"	110	68	583	-	38	150	215	312	150	150	280	250	258	190	12	139	15	77.2
BNMD 32/210B/A	G 2"	G 1 1/4"	110	68	583	-	38	150	215	312	150	150	280	250	258	190	12	139	15	81.5
BNMD 32/210A/B	G 2"	G 1 1/4"	110	70	627	-	38	170	215	360	150	150	298	268	286	216	12	152	15	103.1
BNMD 40/180D/B	G 2"	G 1 1/2"	121	54	535	6	-	155	215	295	145	145	205	175	180	140	10	134	15	66.8
BNMD 40/180C/A	G 2"	G 1 1/2"	121	68	588	-	38	150	215	312	145	145	280	250	258	190	12	133	15	-
BNMD 40/180B/A	G 2"	G 1 1/2"	121	68	588	-	38	150	215	312	145	145	280	250	258	190	12	133	15	82.6
BNMD 40/180A/B	G 2"	G 1 1/2"	121	70	632	-	38	170	215	360	145	145	298	268	286	216	12	146	15	-